

SULLY 315L 4C

Manual

4-COLOUR LED SINGLE LENS LUMINAIRE

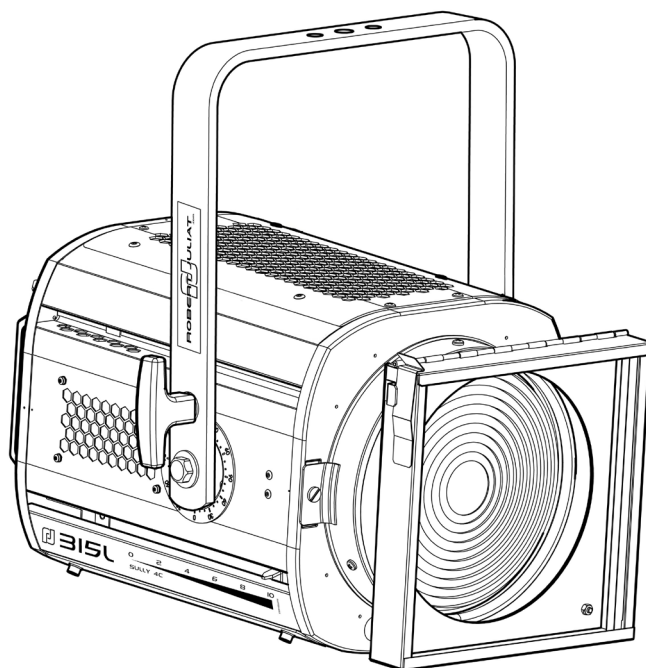

200 W LED

Type	Standard	North American
Fresnel	315LF 4C	315CLF 4C
Pebble Convex	315LPB 4C	315CLPB 4C

Product
Updates:



V2

- FIRMWARE: V2.xx



ROBERT JULIAT

DN41222300-B (EN)

Released: 15/12/25

Robert Juliat S.A.S. 32, rue de Beaumont, F 60530 Fresnoy-en-Thelle - phone : +33 (0)3 44 26 51 89 - info@robertjuliat.fr

www.robertjuliat.com

Table of Contents

1 User's instructions	1	4.10 Beam size adjustment	24
2 Presentation	2	4.10.1 Range.....	24
2.1 Functions.....	2	4.10.2 Control.....	24
2.2 Identification labels.....	3	4.11 Orientation	25
2.3 Accessories included.....	3	4.11.1 Range.....	25
2.4 Accessories.....	4	4.11.2 Control.....	25
3 Set-up	5	4.12 Colour and diffuser filters (gels)	26
3.1 Mechanics.....	5	4.13 Beam shaping	27
3.1.1 Operating positions.....	5	4.13.1 Range.....	27
3.1.2 Minimum distance between a flammable material.....	5	4.13.2 Control.....	27
3.1.3 Instructions for use.....	5	5 Controls and parameters	28
3.1.4 Hanging.....	5	5.1 Local display and controls	28
3.1.5 Safety cable.....	6	5.1.1 Display.....	28
3.2 Electrical information.....	6	5.1.2 Home screen.....	28
3.2.1 LED source.....	6	5.1.3 Menu.....	29
3.2.2 Power supply.....	6	5.1.4 Parameters.....	30
3.3 DATA.....	7	5.1.4.1 Backlight.....	30
3.3.1 DMX 512-A / RDM.....	7	5.2 DMX512 - A remote control	30
3.4 Accessories.....	8	5.2.1 Protocol.....	30
3.4.1 Front filter holder.....	8	5.2.2 Configuration.....	30
3.4.2 Barndoors.....	8	5.2.3 Parameters.....	31
3.4.3 Changing lense.....	9	5.2.3.1 DMX Hold.....	31
3.4.4 Narrow beam extender for 315LPB.....	10	5.2.3.2 User ID.....	32
4 Operations	11	5.2.3.3 Transfer settings.....	32
4.1 Source type.....	11	5.2.4 DMX chart.....	33
4.1.1 Range.....	11	5.2.5 DMX ranges.....	33
4.1.2 Control.....	11	5.2.5.1 Strobe duration.....	33
4.2 Light intensity.....	12	5.2.5.2 Strobe speed.....	33
4.2.1 Range.....	12	5.2.5.3 Response time.....	33
4.2.2 Control.....	12	5.2.5.4 Control mode.....	34
4.2.3 Parameters.....	12	5.2.5.5 Source Type.....	34
4.2.3.1 Dimming resolution - DMX only.....	12	5.2.5.6 Gel Type.....	35
4.2.3.2 Dimming curve.....	12	5.2.5.7 Gel references.....	35
4.2.3.3 Dimming mode.....	13	5.2.5.8 Gel Saturation.....	35
4.2.3.4 Response time.....	13	5.2.5.9 Gel Transmission.....	35
4.2.3.5 DimShift.....	13	5.2.5.10 Gel Fade Time.....	35
4.2.3.6 Set maximum position.....	13	5.2.5.11 Gel Fade Mode.....	36
4.3 Colour mix.....	14	5.2.5.12 CCT.....	36
4.3.1 Range.....	14	5.2.5.13 DeltaUV.....	36
4.3.2 Control.....	15	5.2.5.14 Colour CIE x.....	36
4.3.3 Parameters.....	16	5.2.5.15 Colour CIE y.....	36
4.3.3.1 Colour space selection.....	16	5.3 RDM remote control	36
4.3.3.2 High Quality / High Brightness.....	17	5.3.1 Protocol.....	36
4.4 Colour Temperature CCT.....	17	5.3.2 PIDs list.....	37
4.4.1 Range.....	17	5.3.3 Parameters.....	38
4.4.2 Control.....	18	5.4 Fan cooling modes	38
4.4.3 Parameters.....	18	5.4.1 Range.....	38
4.4.3.1 High Brightness / High Quality.....	18	5.4.2 Control.....	38
4.4.3.2 DimShift.....	18	5.5 LEDs Feedback	39
4.5 High Brightness / High Quality.....	18	5.5.1 Trouble shooting.....	39
4.5.1 Range.....	18	5.5.2 Parameters.....	39
4.5.2 Control.....	18	5.5.2.1 Auto-OFF.....	39
4.6 Colour filters.....	19	5.6 Home values	40
4.6.1 Range.....	19	5.6.1 Range.....	40
4.6.2 Control.....	19	6 Service	41
4.6.3 Parameters.....	20	6.1 Preventive maintenance.....	41
4.6.3.1 Saturation.....	20	6.1.1 Frequency.....	41
4.6.3.2 Transmission.....	20	6.1.2 General cleaning.....	41
4.6.3.3 Gel Fade Time and Mode.....	21	6.1.3 General visual check.....	41
4.7 Strobe.....	22	6.1.4 LED source.....	41
4.7.1 Range.....	22	6.1.5 Optics.....	41
4.7.2 Control.....	22	6.1.6 LED house cleaning.....	41
4.8 Response time.....	22	6.2 Analysis	42
4.8.1 Range.....	22	6.3 Electronic thermal management system	42
4.8.2 Control.....	22	6.4 Firmware update	42
4.9 DimShift.....	23	6.5 Factory defaults	43
4.9.1 Range.....	23	6.5.1 Modes.....	43
4.9.2 Control.....	24	6.5.2 Control.....	43
		Annex 1 - Gel References	44
		Annex 2 - Home values	45

1 User's instructions

GENERAL INSTRUCTIONS

1. Not for residential use.
2. These fixtures must only be serviced by a qualified technician.
3. In addition to the instructions indicated on this page, relevant health and safety requirements of the appropriate EU Directives must be adhered to at all times.
4. This fixture is in compliance with section 17 - Lighting appliance for theatre stages, television, cinema and photograph studios.
Standards NF EN 60598-1, NF EN 60598-2-17, Low Voltage Directive 2014/35/UE & EMC Directive 2014/30/UE.
5. This fixture is rated as IP20, and is for indoor use only.

FIXTURE

6. Ensure fixture is correctly mounted on an appropriate support.
7. Protection screens and lenses must be replaced in the event of any damage, such as cracks or deep scratches, since these might reduce performance.
8. When hung or flown the fixture must be secured by an additional hanging accessory (such as a safety cable or bond) of suitable length.
9. Safety bonds or cables must be securely attached to the back of the fixture and be as short as possible, or rolled up as necessary, to minimise travel distance should the fixture be dislodged.
10. Movable accessories (scroller, etc.) must also be secured with a suitable safety cable or bond at the front of the fixture.
11. The combined weight of both the fixture and the accessories must be considered when choosing the load-bearing capability of safety cable or bond.
12. Do not open lighting fixture when the source is on.
13. WARNING: LED source becomes hot during use. Allow fixture to cool before servicing.
14. Do not tamper with design of fixture nor any of its safety features.
15. Tighten electrical mains cable connections regularly and replace with one of identical specification if damaged.
16. Use only with correct power supply.

VENTILATION

17. Keep well away from flammable material.
18. Not for outdoor use. Do not cover. Do not permit fixture to get wet.
19. To avoid overheating, do not obstruct air vents.
20. Ensure any cooling fans are in correct working order. If fans are not working, turn fixture off immediately and service as necessary.

CLEANING

21. Do not touch the LED source with your fingers.
22. To clean the optical parts, use a soft cloth in combination with distilled water or isopropyl alcohol recommended for coated optics. Do not use any cleaning product that contains solvents or abrasives, as these can cause surface damage.
Dry with a soft lint-free cloth.
23. Regularly remove dust with a soft lint-free cloth.
24. If the fixture has filters, they must be cleaned frequently.

POWER SUPPLY

25. Disconnect from the mains before servicing.
26. Mains connection only. Do not connect to "electronic output" such as dimmer.
27. Ensure power supply circuit breakers, always remain accessible.

PLEASE NOTE

This product has been built to conform to European standards relating to professional lighting equipment. Any modification made to our products will void the manufacturers' warranty.

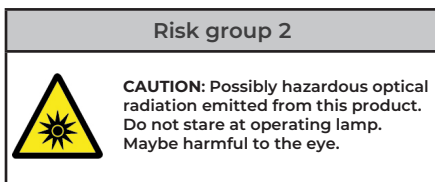

Risk group 2. Luminaires should be positioned so that prolonged staring into luminaire at a distance closer than 7,8 m for the 315LPB 4C and 7 m for the 315LF 4C is not expected.

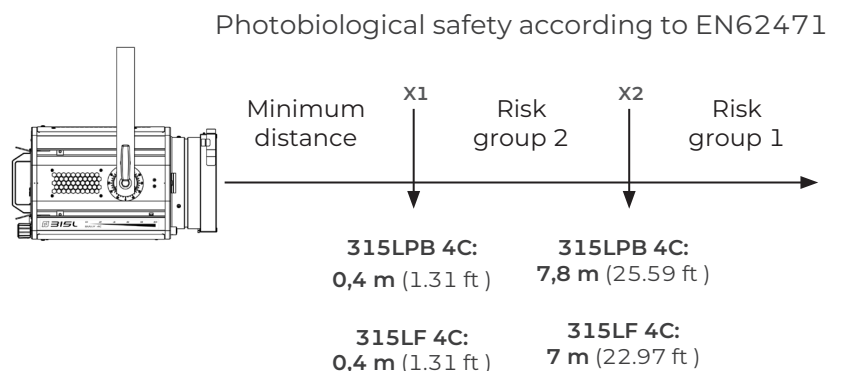

2.1 Functions

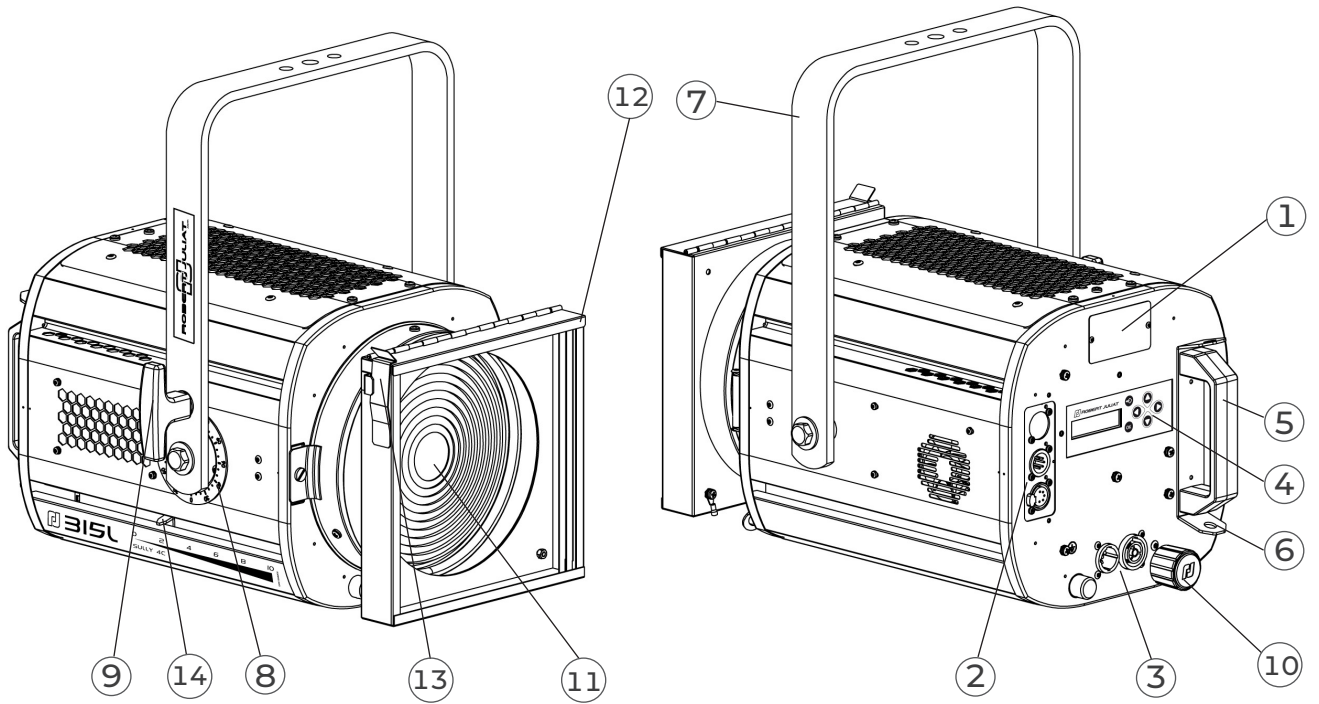

Description	
1. Identification plate	11. Lens (Fresnel or Pebble)
2. Data connector (IN and OUT)	12. Accessories and colour filter holders
3. Power connector (IN and OUT)	13. Accessories and colour filter holders locking system
4. Local display and controls	14. Focus index
5. Handle	
6. Safety cable attachment point	
7. Hanging yoke	
8. Tilt index	
9. Tilt locking handle	
10. Focus adjustment	

2.2 Identification labels

Description	
	<ol style="list-style-type: none"> 1. MOD. : Model 2. VERS. : Version 3. U : Nominal voltage input (V) 4. I : Nominal intensity (A) 5. P : Maximum power input (W) 6. IP : International Protection Rating 7. t°a : Maximum ambient temperature (°C) 8. t°c : Maximum external temperature of the unit (°C) 9. Net weight (kg) 10. Minimum distance between a flammable material and the lighting unit (m) 11. LED type 12. Serial number 13. Replace broken glass 14. Class 1 product label 15. Read manual first label 16. European conformity label 17. WEEE directive label 18. CEI-TR-62778 - Do not stare at light source 19. EN62471 - Risk group 20. UKCA (UK Conformity Assessed) label
<p>Units :</p> <ul style="list-style-type: none"> - Weight = kilogram (kg). - Intensity = Ampere (A). - Voltage = Volt (V). - Frequency = Hertz (Hz). - Temperature = degree Celsius (°C). 	

2.3 Accessories included

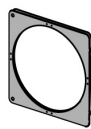

①



②

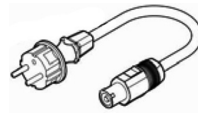

③

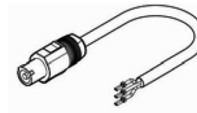

④

Reference	Description
1 PF1000M2	215 x 215 mm (8.5 x 8.5 in) metal filter holder
2 DN41222700	Quick Start manual
3 CAL03	3 meter power cable (3G1,5 HO7RNF) with Neutrik PowerCon® True1 TOP and CEE 7/7 (2P+T NF/SCHUKO) connectors (standard version)
4 CAL04	1,50m power cable UL/CSA with Neutrik PowerCon® True1 TOP connector (North American version)

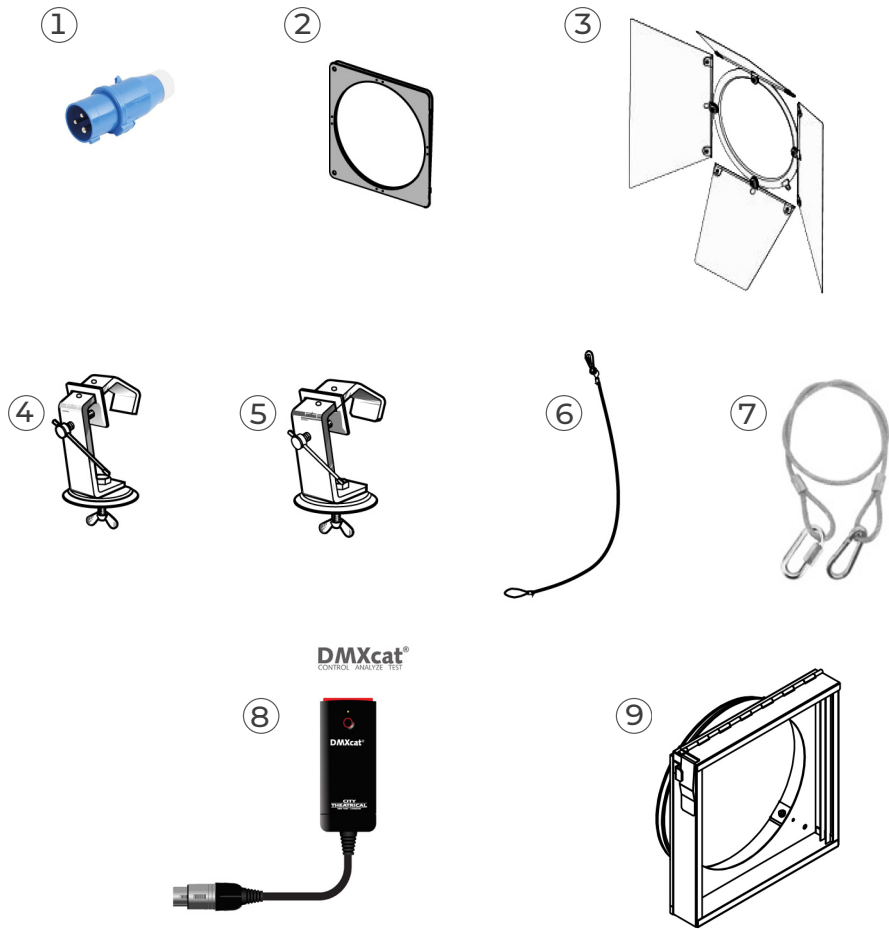

	Reference	Description
1	PCP1716A	16A blue 2P+E 6h IEC60309 power connector
2	PF1000M2	215 x 215 mm metal filter holder
3	CF1000	4 rotating leaves on a rotating barndoor - 215 x 215 mm (without safety cable) - weight: 1.03 Kg
4	876	40 x 10 mm hook clamp with 28mm screw for Ø35 to Ø50 mm
5	880	40 x 10 mm hook clamp with 28mm screw for Ø50 to Ø63 mm
6	CS2	Safety cable Ø3 mm (length = 600 mm)
7	CS5	Safety cable Ø1,5 mm (length = 300 mm) for front accessory with karabiner and quick link
8	DMXcat	Bluetooth DMX/RDM Multifunction test tool - City Theatrical DMXcat®
9	ROPT2	Narrow beam extender for 315LPB

3 Set-up

3.1 Mechanics

3.1.1 Operating positions

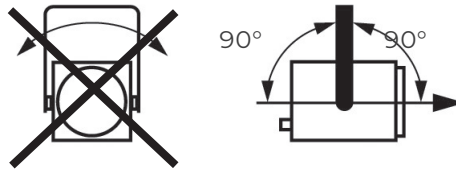

3.1.2 Minimum distance between a flammable material and the lighting unit

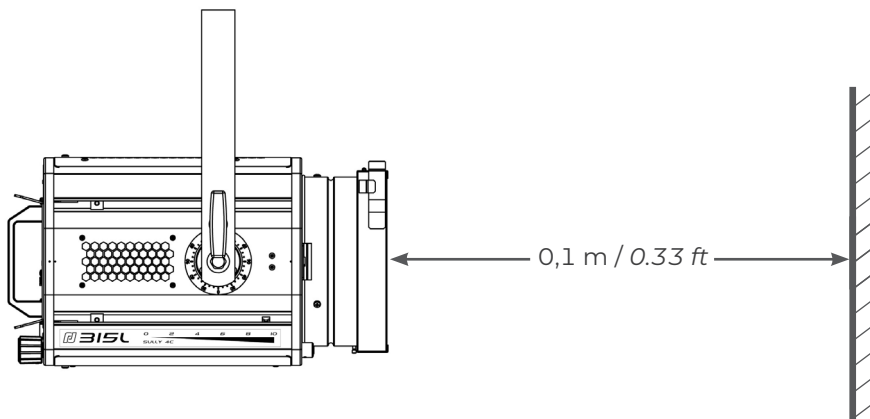

3.1.3 Instructions for use

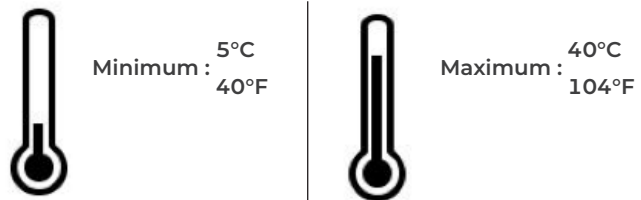

IP20 - Indoor use only

3.1.4 Hanging

- Ensure fixture is correctly mounted on an appropriate support

Net weight:
Fresnel / Pebble: 11 kg (24.2 lbs)

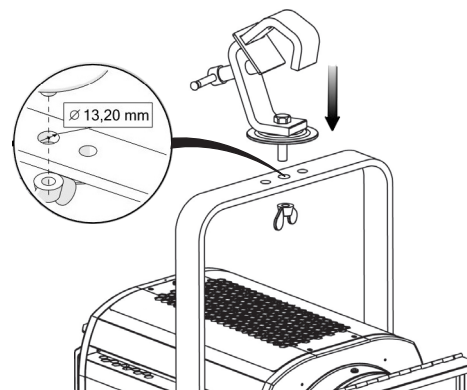

3.1.5 Safety cable

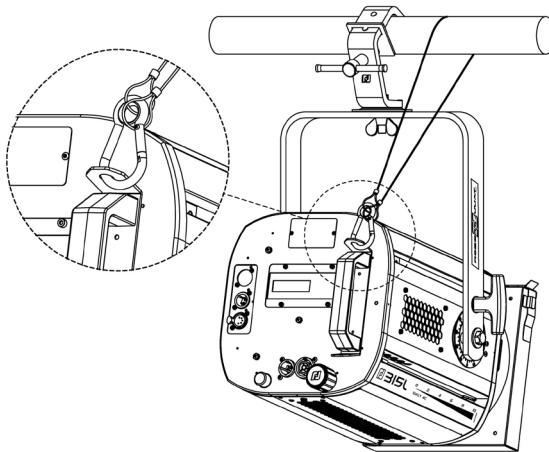

- When hung or flown the fixture must be secured by an additional hanging accessory (such as a safety bond or cable) of suitable length.
- The combined weight of both the fixture and the accessories must be considered when choosing the load-bearing capability of safety cable or bond.
- Safety cables or bonds must be securely attached to the back of the fixture and be as short as possible, or rolled up as necessary, to minimise travel distance should the fixture be dislodged.

3.2 Electrical information

3.2.1 LED source



Never touch or scratch the LED surface.
See 6.1.4 LED cleaning procedure if cleaning is necessary.

3.2.2 Power supply

Power supply			
Voltage	Frequency	Input power	Connectors
100 → 264 V	50-60 Hz	0.88 A / 175 W @ 230V cos γ = 0,87 1.67 A / 178 W @ 110V cos γ = 0,98 1.82 A / 178 W @ 100V cos γ = 0,99 180 W max, Max: 2.1 A	Neutrik powerCON TRUE1 TOP Input : ref. NAC3FPX-TOP



- Class 1 product. **This luminaire must be earthed.**
- Must be connected directly to AC power. **Do not connect to dimmer power.**
- Automatic mains voltage detection.

Daisy chain:

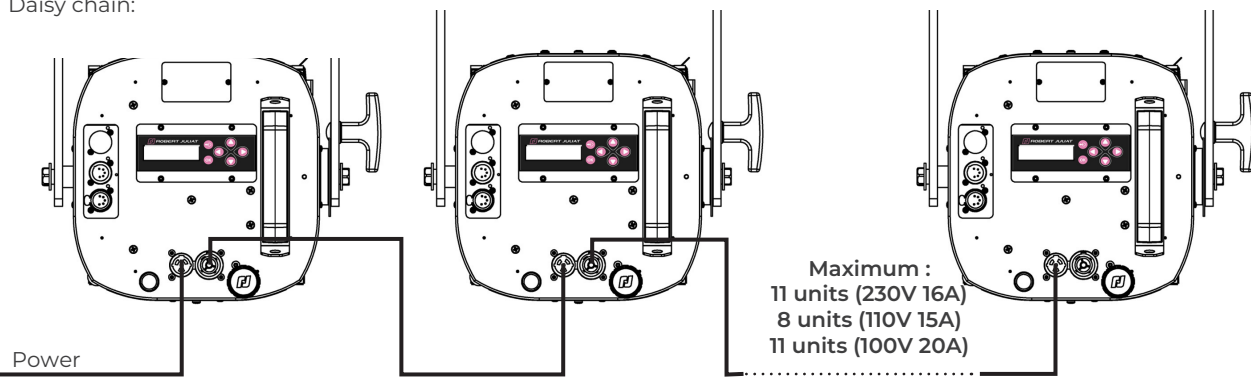

Power cable

Power cable		Connector	Mains plug	Cable type	Cable length	Wiring
1	Standard version	Neutrik® powerCON TRUE1 TOP NAC3FX-W-TOP	CEE7/7	3G1.5 H07RNF	3 m 9.8 ft	Live: Brown Neutral: Blue Ground: Yellow/Green
2	North American version		-	14AWG SJ TYPE (UL/CSA)	1.5 m 4.9 ft	Live: Black Neutral: White Ground: Green

3.3 DATA

3.3.1 DMX 512-A / RDM

Protocol	Input connector	Output connector
USITT DMX 512-A RDM	XLR 5-pin	XLR 5-pin

DATA connectors			
PIN #	DMX	Description	
1	Shielding	Foil & Braided Shield	
2	DMX (-)	1 st conductor of 1 st twisted pair	
3	DMX (+)	2 nd conductor of 1 st twisted pair	
4	Not used	1 st conductor of 2 nd twisted pair	
5	Not used	2 nd conductor of 2 nd twisted pair	

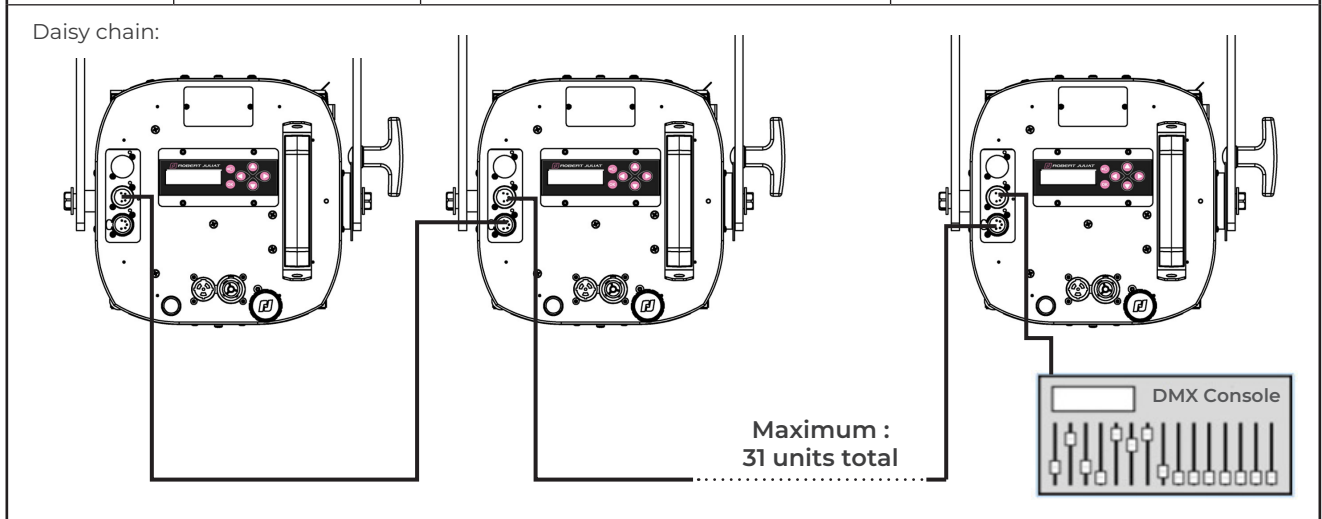

3.4 Accessories

3.4.1 Front filter holder

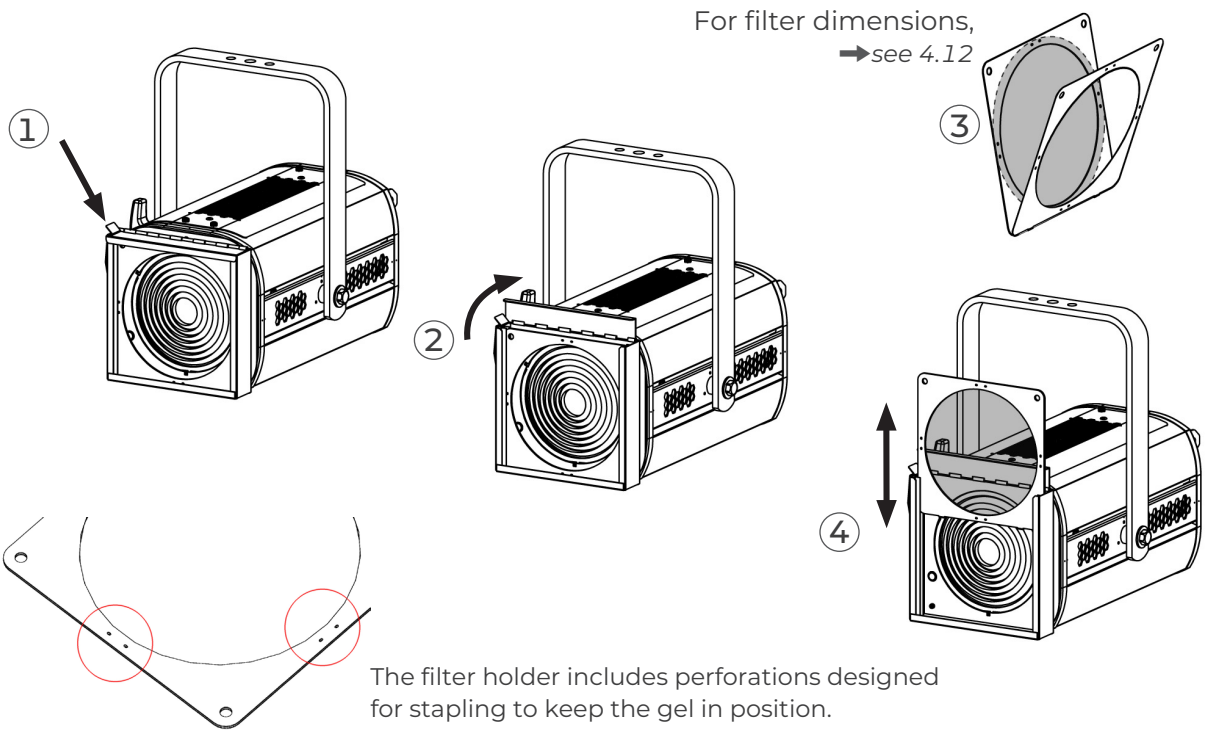

3.4.2 Barndoors

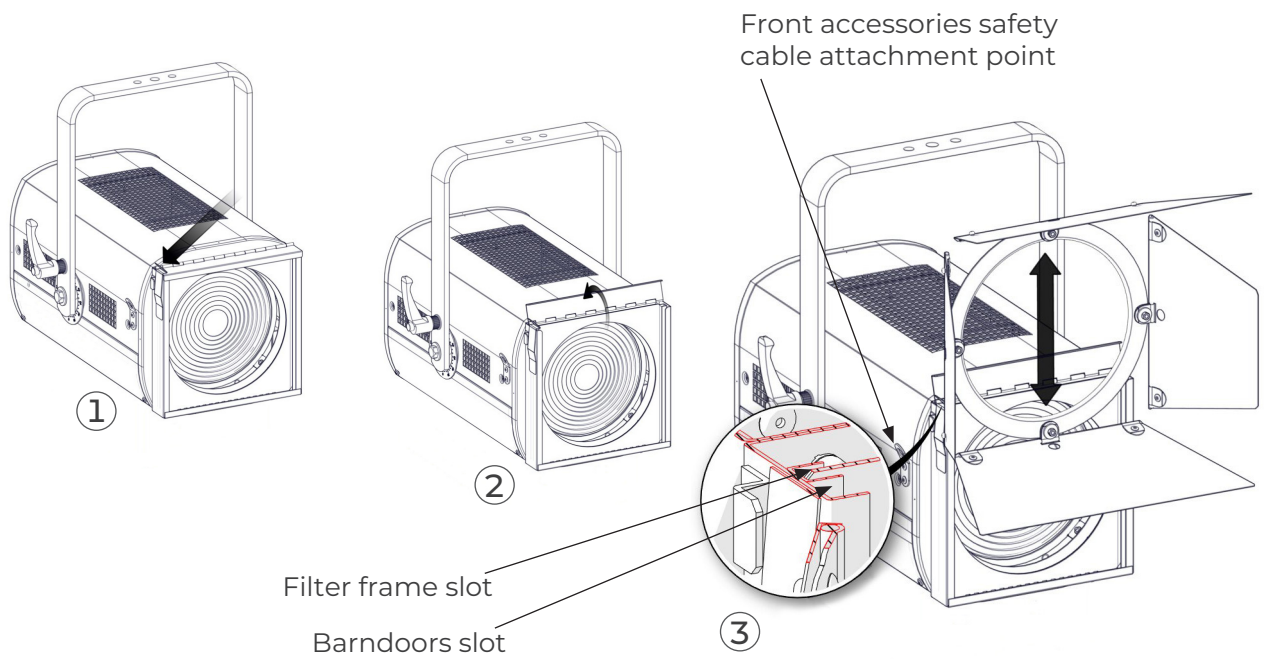

3.4.3 Changing lens

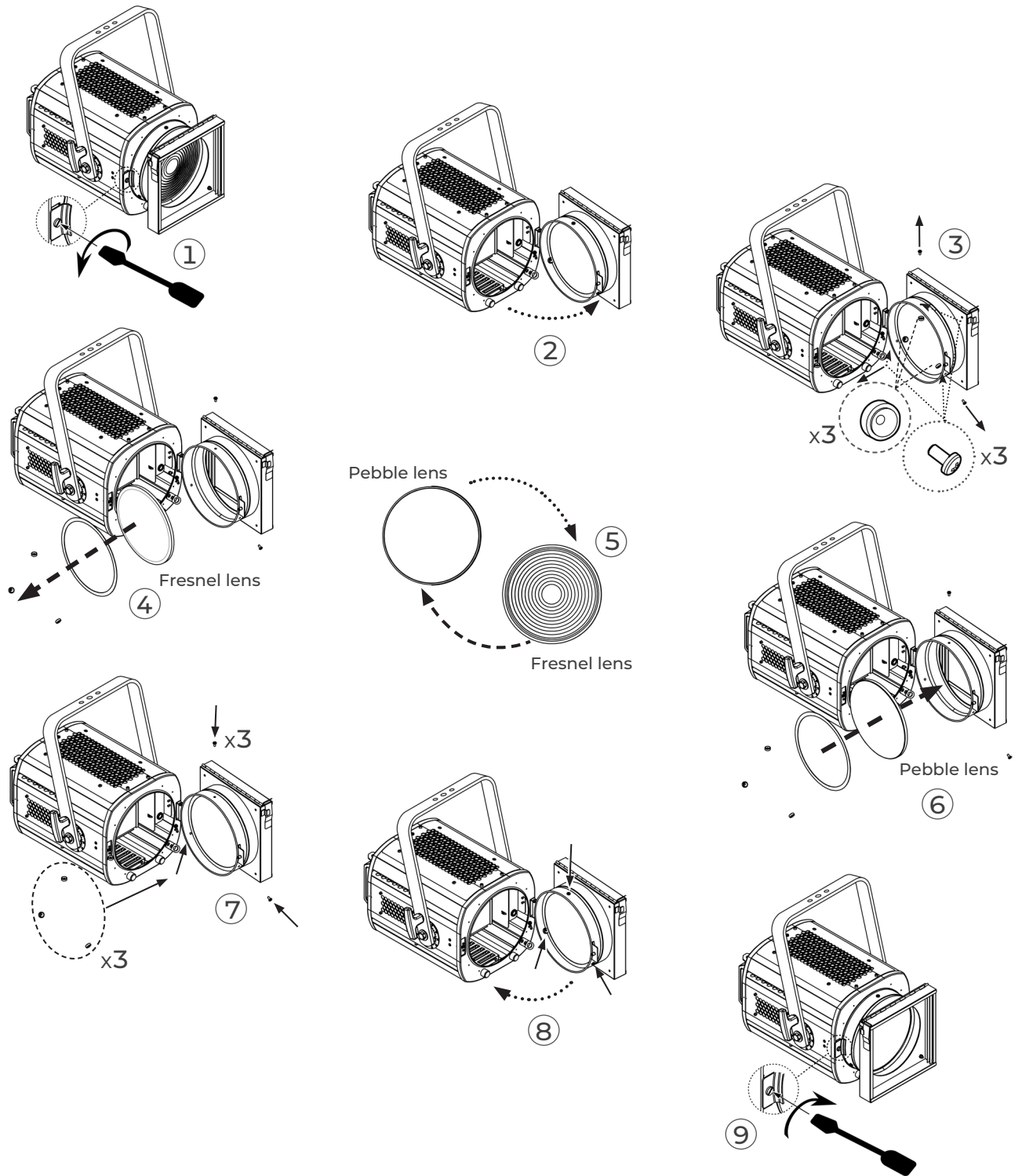

3.4.4 Narrow beam extender for 315LPB

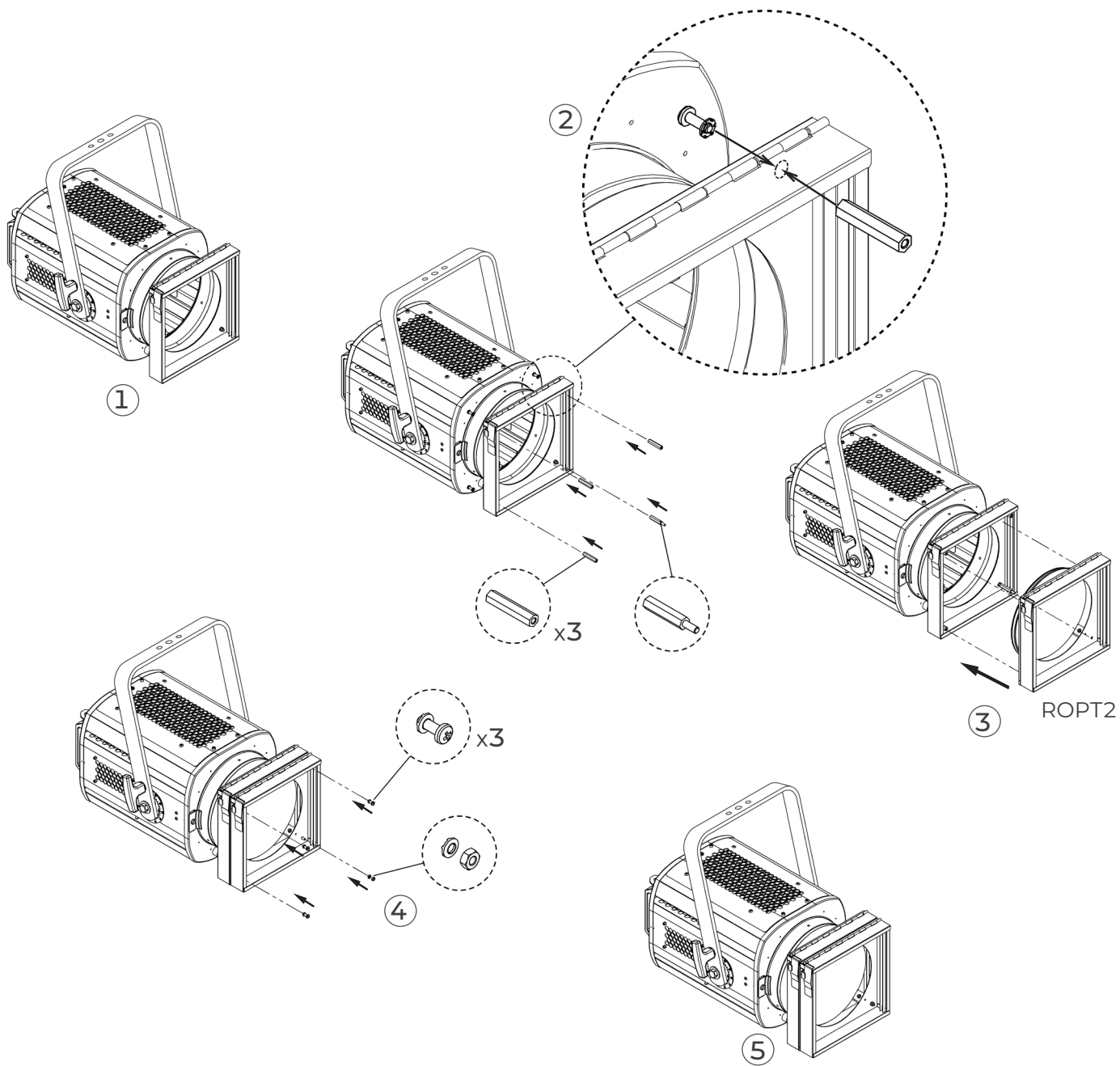

4.1 Source type

4.1.1 Range

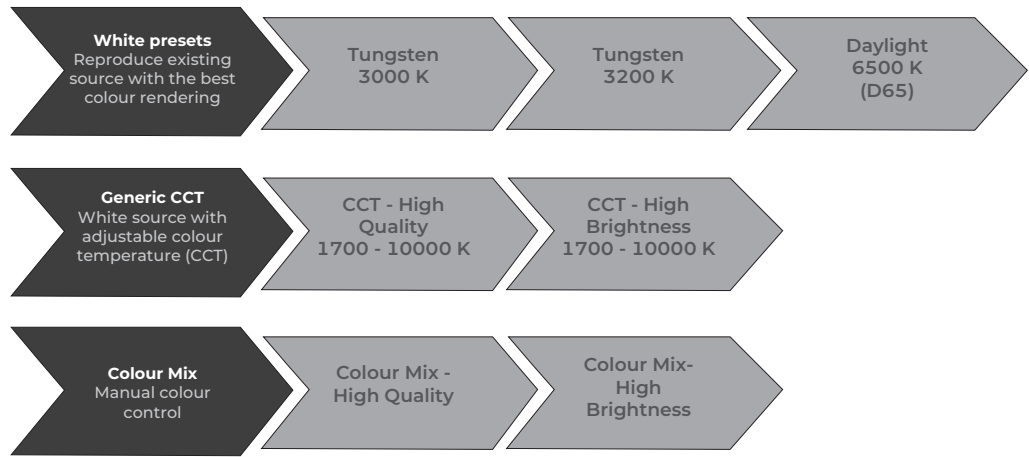

Source type	Compatible functions					
	Colour Mix	Colour Temperature CCT	High Brightness	High Quality	Colour Filters	DimShift
	See 4.3	See 4.4	See 4.5	See 4.5	See 4.6	See 4.9
Tungsten 3200 K - DimShift				X	X	X
Tungsten 3000 K - DimShift				X	X	X
Tungsten 3200 K				X	X	
Tungsten 3000 K				X	X	
Daylight 6500 K D65				X	X	
Generic CCT - High Quality		X		X	X	
Generic CCT - High Brightness		X	X		X	
Generic CCT - High Quality - DimShift		X		X	X	X
Generic CCT - High Brightness - DimShift		X	X		X	X
Colour Mix - High Quality	X			X		
Colour Mix - High Brightness	X		X			

4.1.2 Control

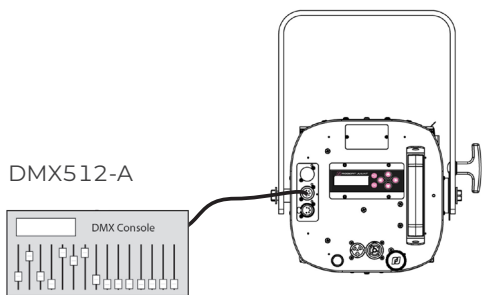

Remotely with DMX512-A protocol
Mode 3 - 4 - 5 - 6
(see 5.2.4 DMX chart for function details)

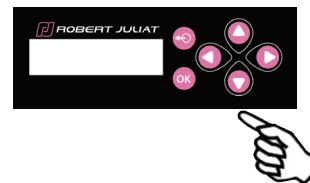

Locally with DMX mode 1 - 2 and
Stand Alone mode - see 5.6 Home value

4.2 Light intensity

4.2.1 Range



4.2.2 Control

DMX512-A

DMX Console

Remotely with DMX512-A protocol
Mode 1 - 2 - 3 - 4 - 5 - 6
(see 5.2.4 DMX chart for function details)

Locally via
STAND ALONE mode

Focus mode: when standby screen displayed,
 Push the UP arrow button for 3 secs → Light output = 100% for 1 minute
 Push the UP arrow button to Exit → Light output = 0%

4.2.3 Parameters

4.2.3.1 Dimming resolution - DMX only

→ Set through RDM protocol, DMX control channel or local control

Resolution	DMX mode
8 bits – 255 steps	1
16 bits – 65 535 steps	2 - 3 - 4 - 5 - 6

4.2.3.2 Dimming curve

→ Set through RDM protocol or local control

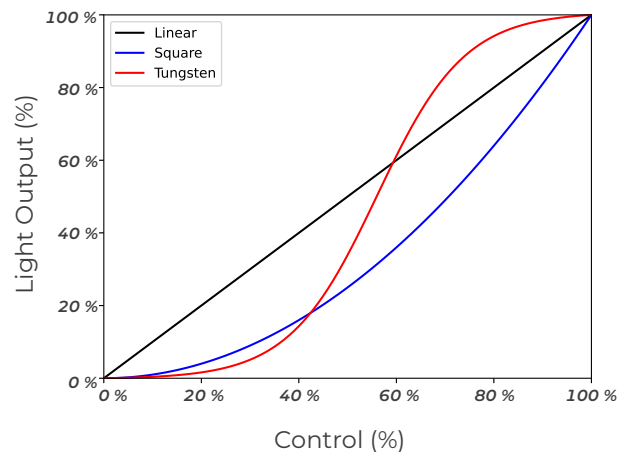

4.2.3.3 Dimming mode

➔ Set through RDM protocol or local control

Mode	Frequency
PWM	1282 Hz / 2500 Hz / 5000 Hz / 6000 Hz / 15000 Hz* / 20000 Hz

(*) Default value

4.2.3.4 Response time

➔ See 4.8

4.2.3.5 DimShift

➔ See 4.9

4.2.3.6 Set maximum position

➔ Set through RDM protocol or local control

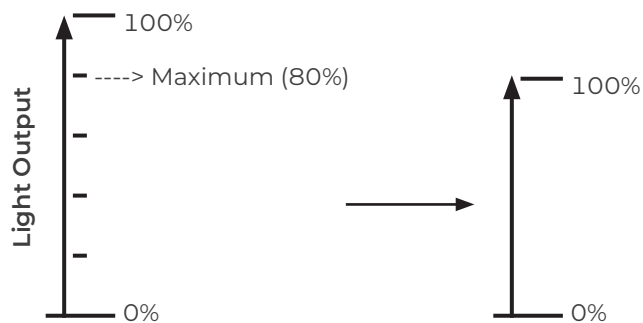

4.3.1 Range

CIE xy control (ANSI E1.54–2021)

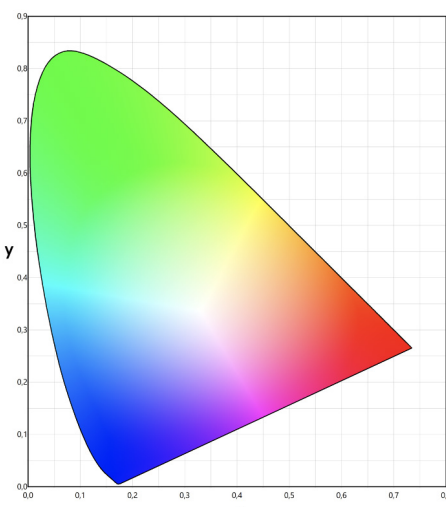

x = 0 → 0,85

y = 0 → 0,85

Colour space: CIE 1931 xy

RGB (ANSI E1.54–2015)

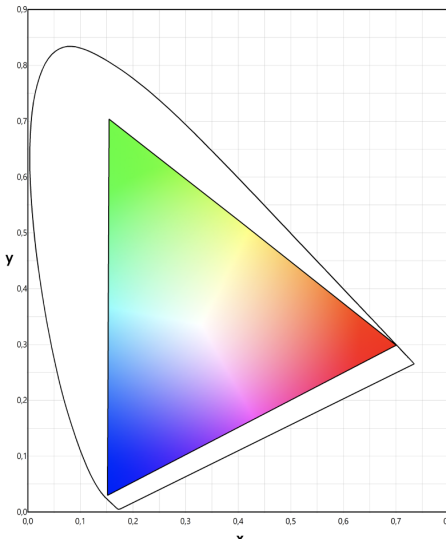

RED 0 % 100 %

GREEN 0 % 100 %

BLUE 0 % 100 %

Colour space:
NATIVE / SRGB-REC. 709 / REC. 2020 / PROPHOTO RGB
→ see 4.3.3

Hue Saturation (ANSI E1.54–2015)

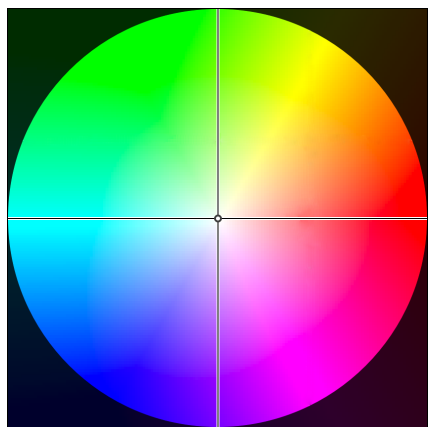

Hue = 0 → 360°
Hue of 0° = Full Red (RGB = 100,0,0)
Hue of 120° = Full Green (RGB = 0,100,0)
Hue of 240° = Full Blue (RGB = 0,0,100)

Saturation = 0 (white) → 100% (saturated colour)

Colour space:
NATIVE / SRGB-REC. 709 / REC. 2020 / PROPHOTO RGB
→ see 4.3.3

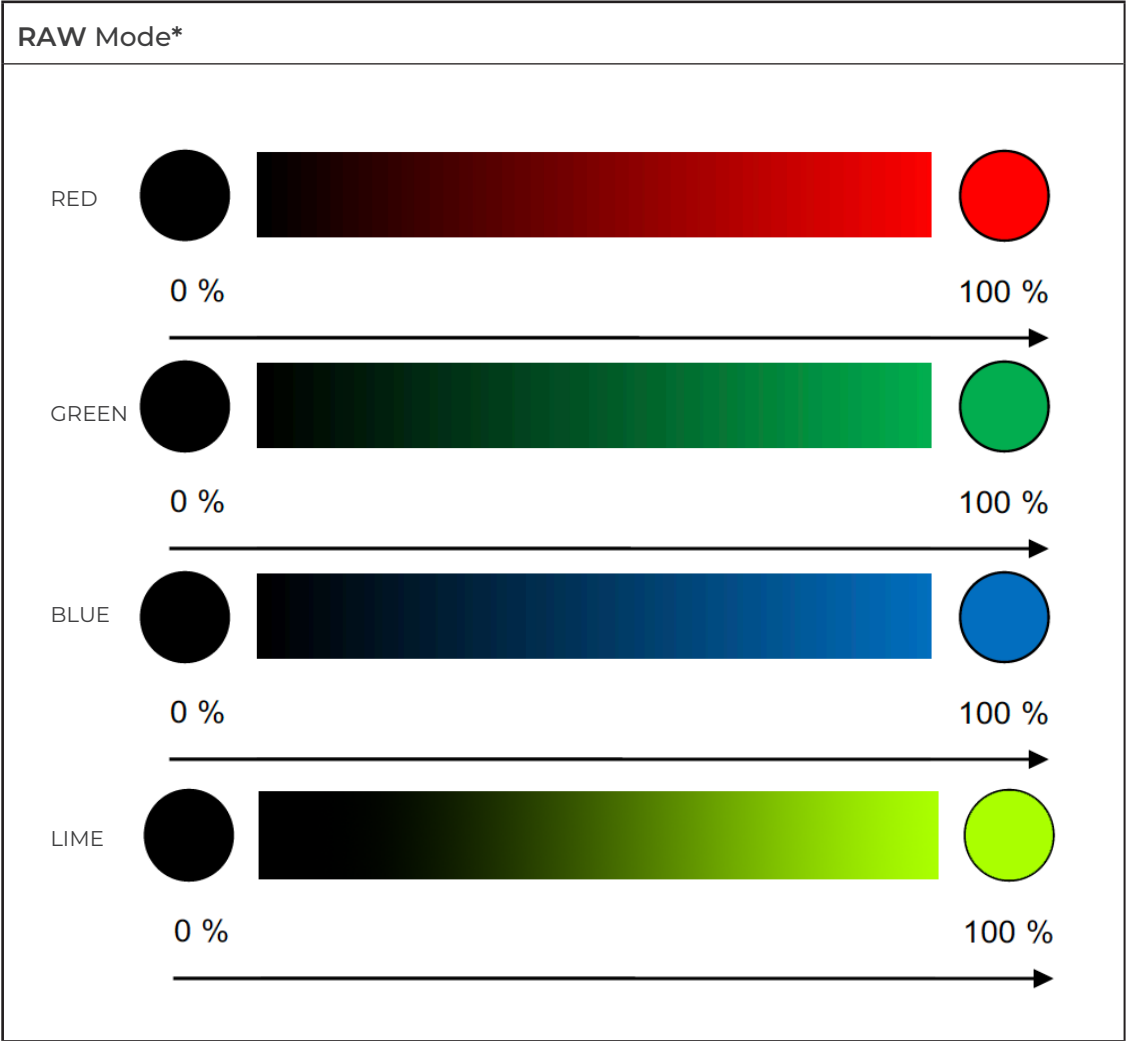

(*) Calibration disabled

4.3.2 Control

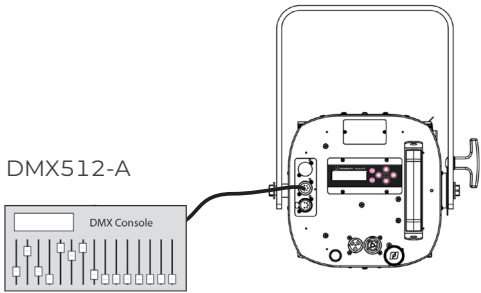

Remotely with DMX512-A protocol

CIE xy	Mode 3 Source type = Colour Mix
Hue Saturation	Mode 4 Source type = Colour Mix
RGB	Mode 5 Source type = Colour Mix
RAW	Mode 6 Source type = Colour Mix

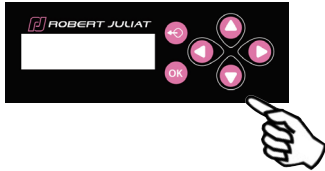

Locally via STAND ALONE mode - see 5.6 Home value

4.3.3 Parameters

4.3.3.1 Colour space selection

- ➔ Set through RDM protocol, DMX control channel or local control
- For RGB and Hue Saturation modes only

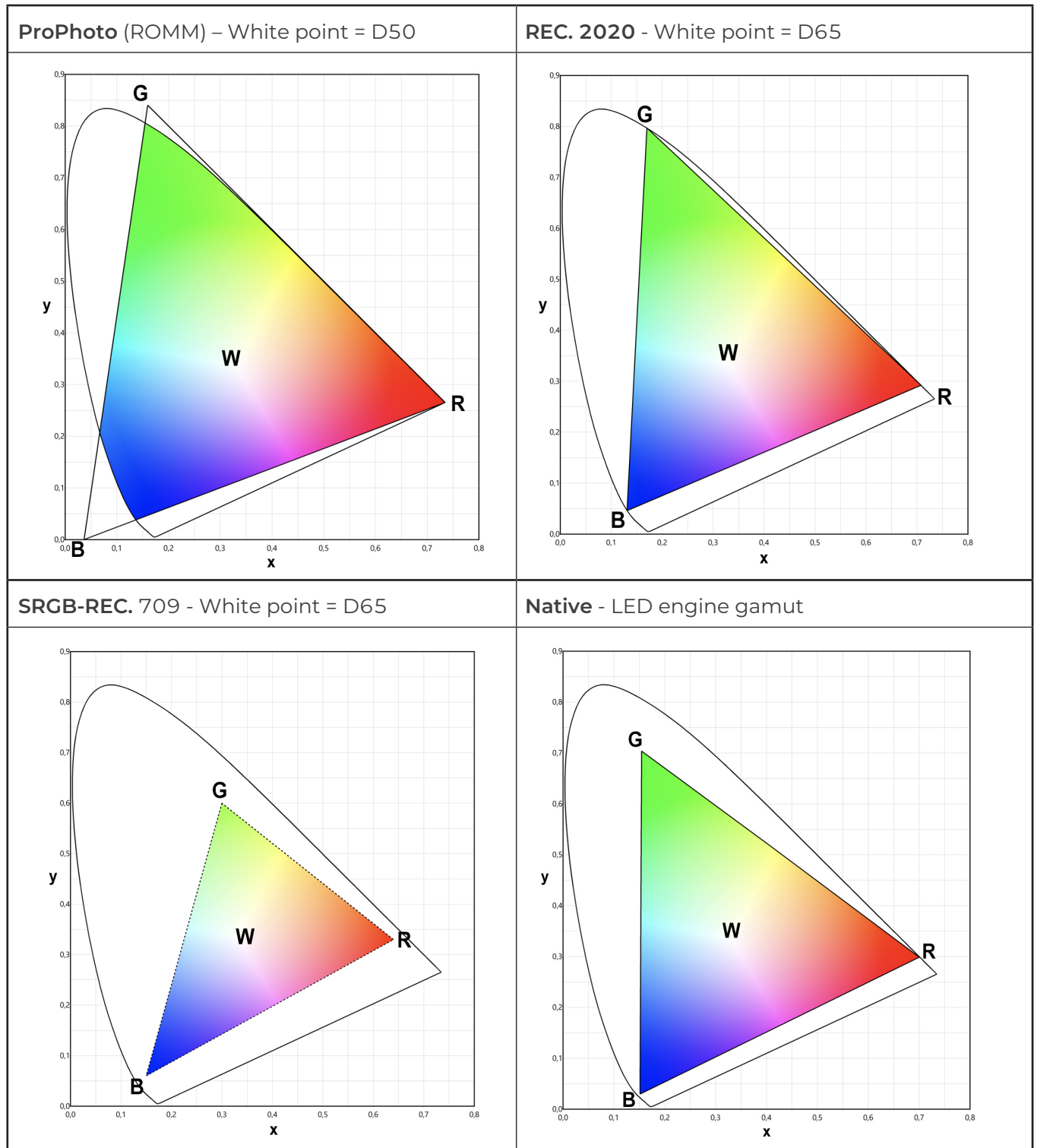

Point	Red	Green	Blue
R	100 %	0 %	0 %
G	0 %	100 %	0 %
B	0 %	0 %	100 %
W (White point)	100 %	100 %	100 %

→ See 4.5

4.4 Colour Temperature CCT

4.4.1 Range

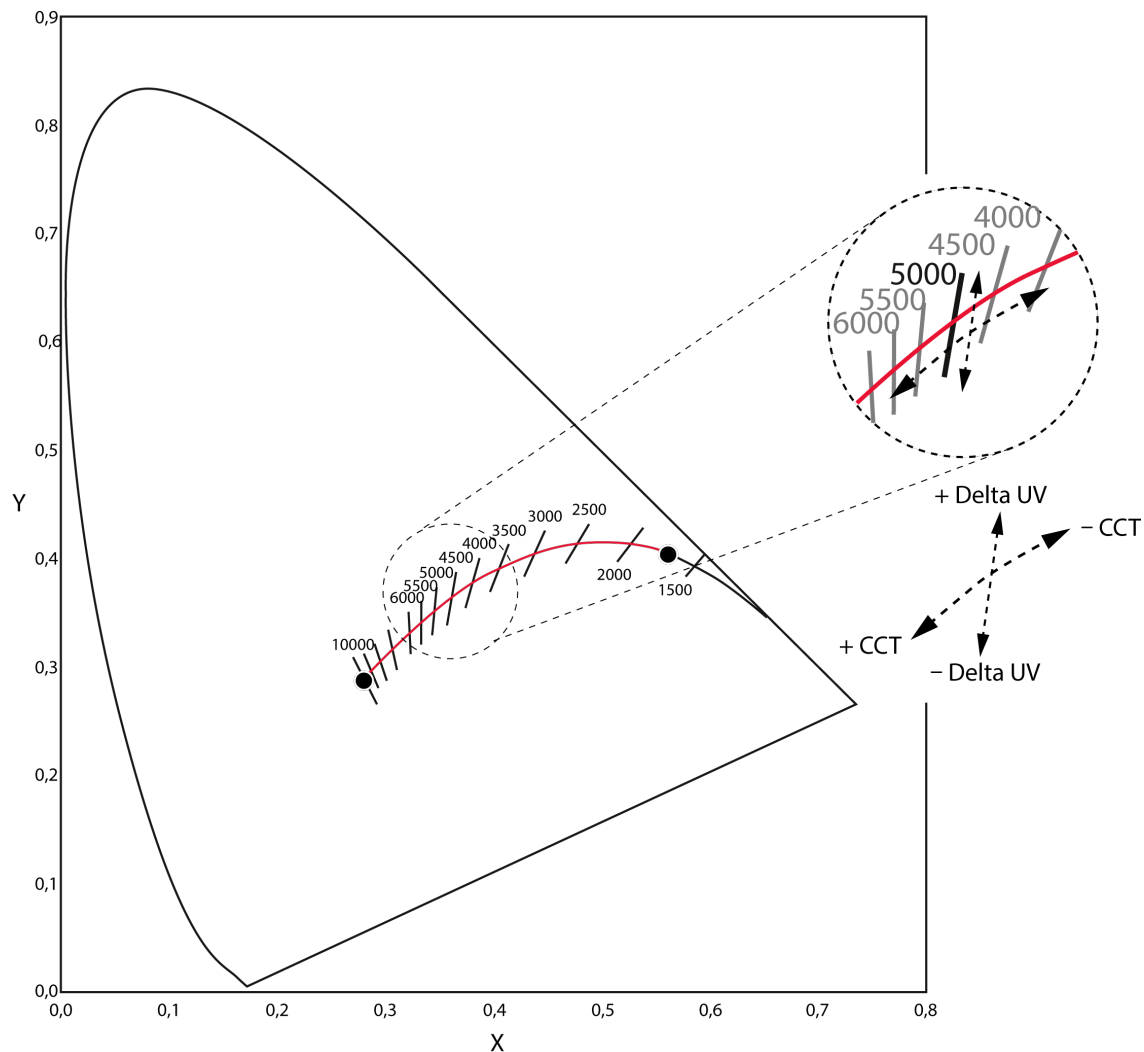

Colour Temperature CCT	<p>0% 100%</p>
	<p>1 700 Kelvin 10 000 Kelvin</p>
Delta UV	<p>-100% (Magenta) +100% (Green)</p>
	<p>0</p>

4.4.2 Control

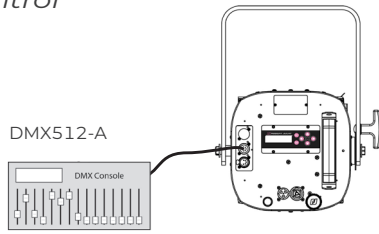

Remotely with DMX512-A protocol
 Mode 3 - 4 - 5 - 6 | Source type = Generic CCT
 (see 5.2.4 DMX chart for function details)

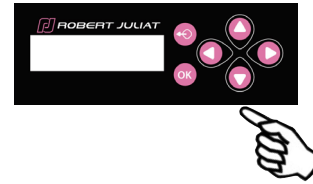

Locally with DMX mode 1 - 2 and
 Stand Alone mode - see 5.6 Home value

4.4.3 Parameters

4.4.3.1 High Brightness / High Quality

➔ See 4.5

4.4.3.2 DimShift

➔ See 4.9

4.5 High Brightness / High Quality

4.5.1 Range

Mode	Light output	Colour rendering
HB – High Brightness	+	–
HQ – High Quality	–	+

Example : Generic CCT @ 5600K

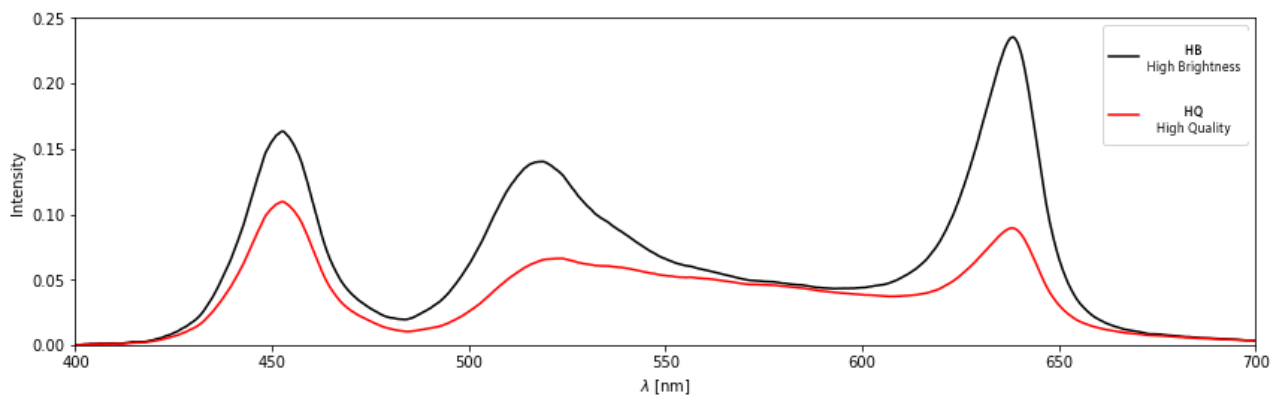

4.5.2 Control

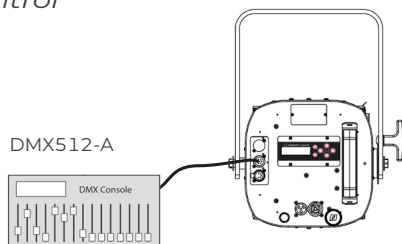

Remotely with DMX512-A protocol
 Mode 3 - 4 - 5 - 6 | Source type = Generic CCT /
 Colour Mix
 (see 5.2.4 DMX chart for function details)

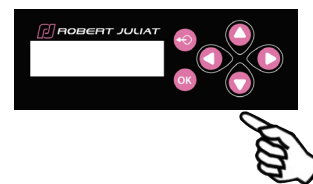

Locally with DMX mode 1 - 2 and
 Stand Alone mode - see 5.6 Home value

4.6.1 Range



(*) Results depend on Source type or Colour temperature - compatible with White presets, Generic CCT source types and DimShift function

4.6.2 Control

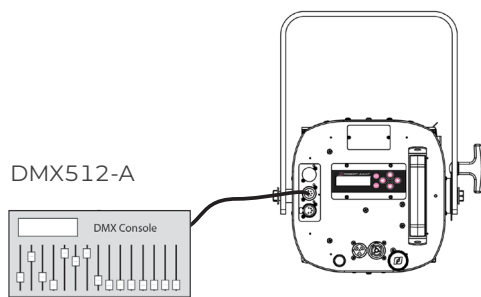

Remotely with DMX512-A protocol
 Mode 3 - 4 - 5 - 6 | Source type = White presets / Generic CCT
 (see 5.2.4 DMX chart for function details)

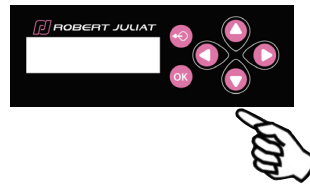

Locally with DMX mode 1 - 2 and Stand Alone mode - see 5.6 Home value

Colour filter selection:

1. Selection of the colour wheel

Wheel 1	Basics
Wheel 2	Numeric: 002 --> 111
Wheel 3	Numeric: 113 --> 181
Wheel 4	Numeric: 182 --> 328
Wheel 5	Numeric: 332 --> 710
Wheel 6	Numeric: 711 --> 799
Wheel 7	Chroma: 048 --> 719
Wheel 8	Chroma: 711 --> 504
Wheel 9	Chroma: 730 --> 007
Wheel 10	Chroma: 765 --> 789
Wheel 11	Chroma: 787 --> 344
Wheel 12	Cosmetic & Corrections
Wheel 13	Dalis selection

2. Selection of the gel reference

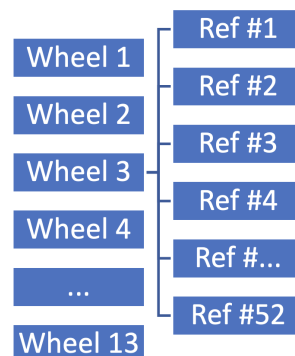

➔ See annex for reference details

4.6.3 Parameters

4.6.3.1 Saturation



4.6.3.2 Transmission



- ➔ Filter transmission is independant from main dimmer. Dimmer intensity can still be operated from 0 to 100% with or without the DimShift function

4.6.3.3 Gel Fade Time and Mode

Transition between 2 colour filters – Gel fade time:

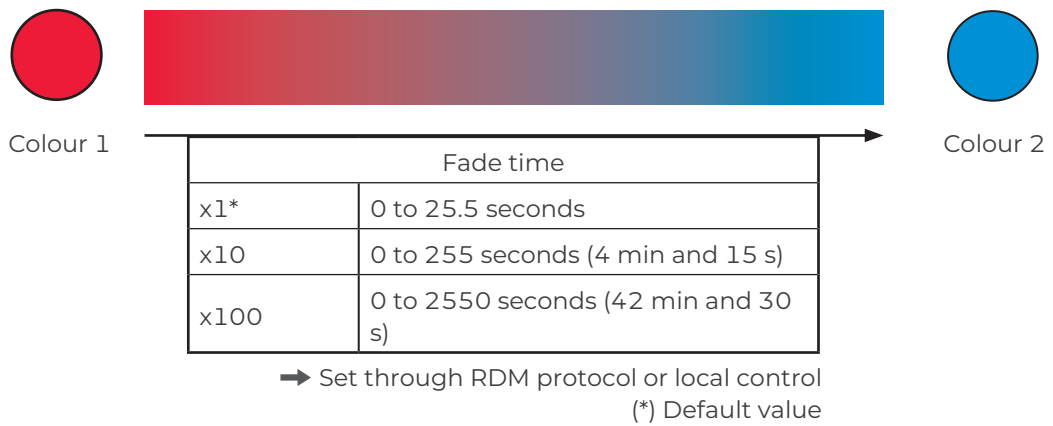

Transition between 2 colour filters - Gel Fade type:

Direct XY + Limit Brightness	
Direct XY	
Open Frame + Limit Brightness	
Open Frame	
Through Black	

4.7.1 Range

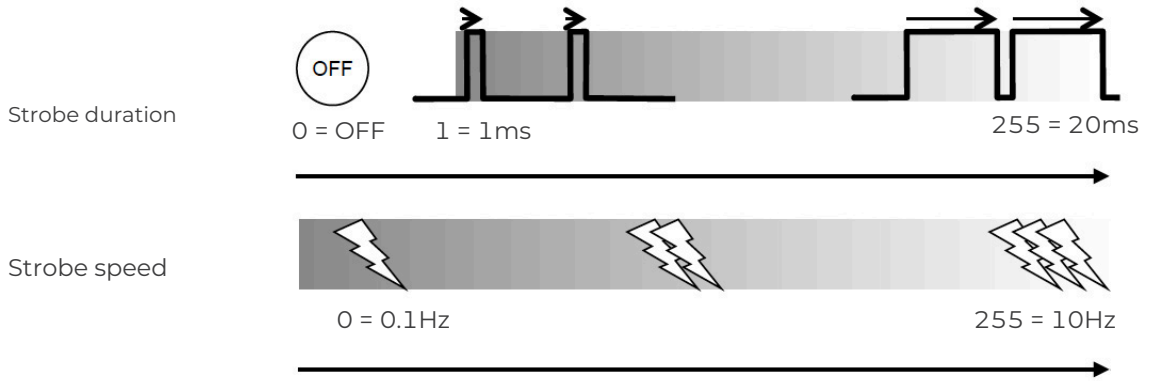

4.7.2 Control

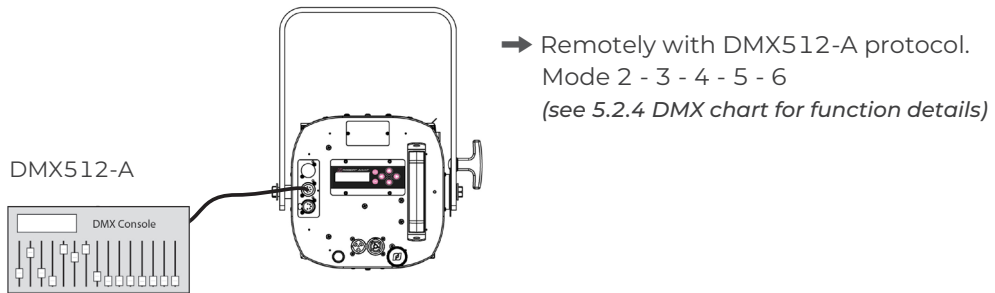

4.8 Response time

4.8.1 Range

Mode	
Default	1000 W tungsten lamp simulation
Tungsten	500 W ————— 5000 W
Linear	0 s ————— 4 s
Linear / Flash by-pass	0 s ————— 4 s Or If flash detected (>50% brightness variation) = 0 s

4.8.2 Control

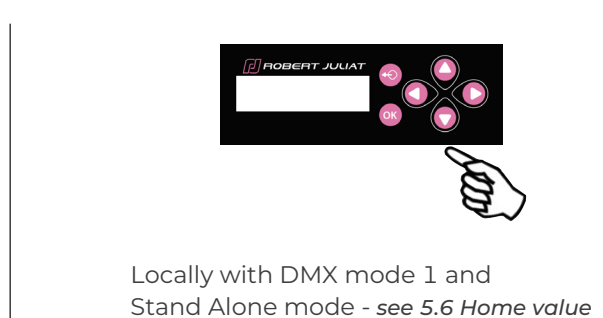
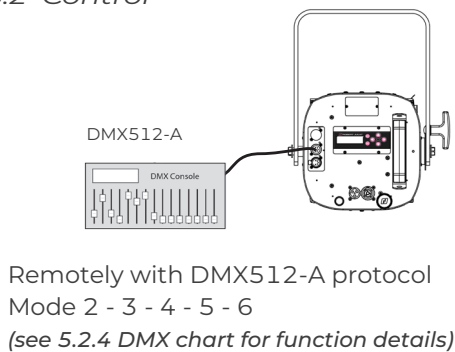

4.9.1 Range

DimShift function:

When dimming the light, the colours follow the Planck curve (tungsten redshift emulation)

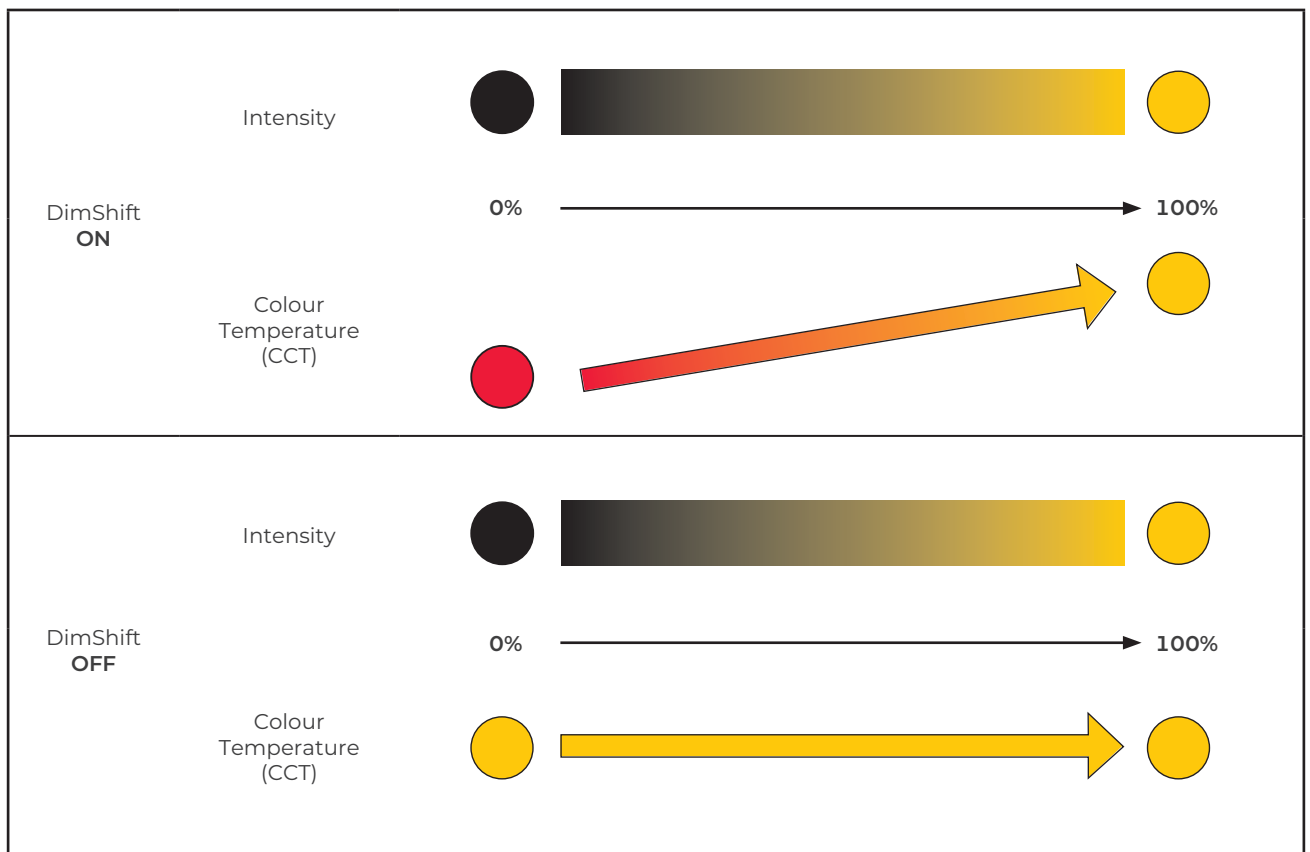
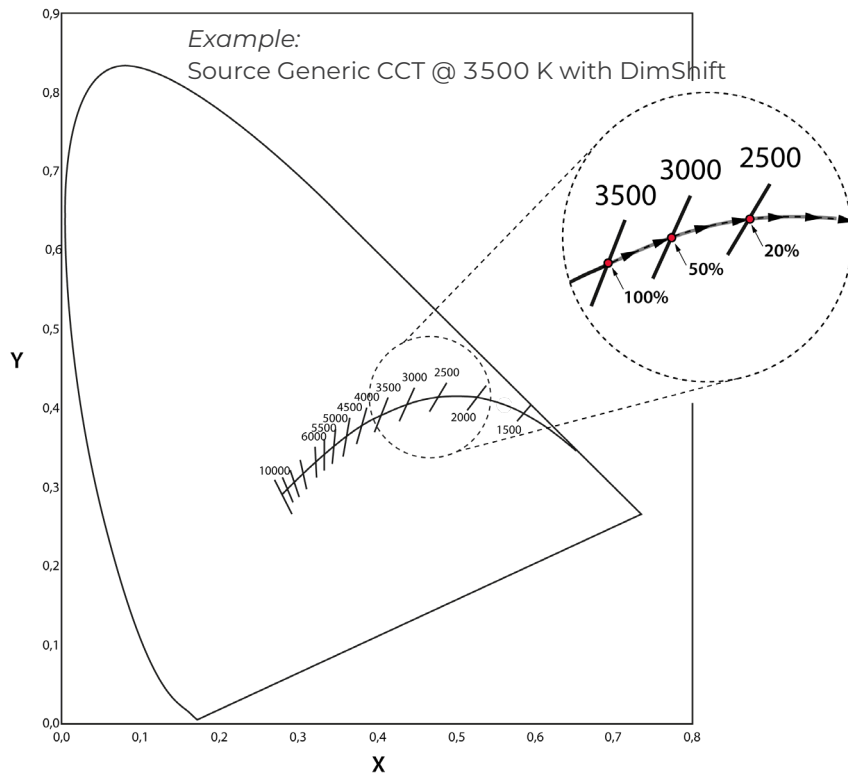

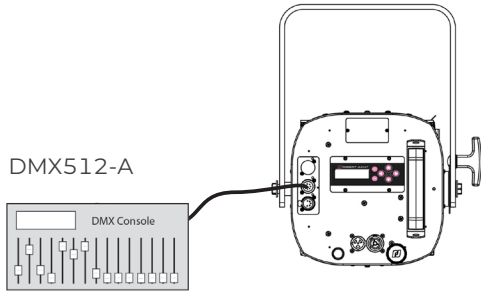

Remotely with DMX512-A protocol
 Mode 3 - 4 - 5 - 6 | Source type = White
 presets / Generic CCT
 (see 5.2.4 DMX chart for function details)

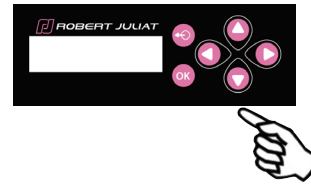

Locally with DMX mode 1 - 2 and
 Stand Alone mode - see 5.6 Home value

4.10 Beam size adjustment

4.10.1 Range

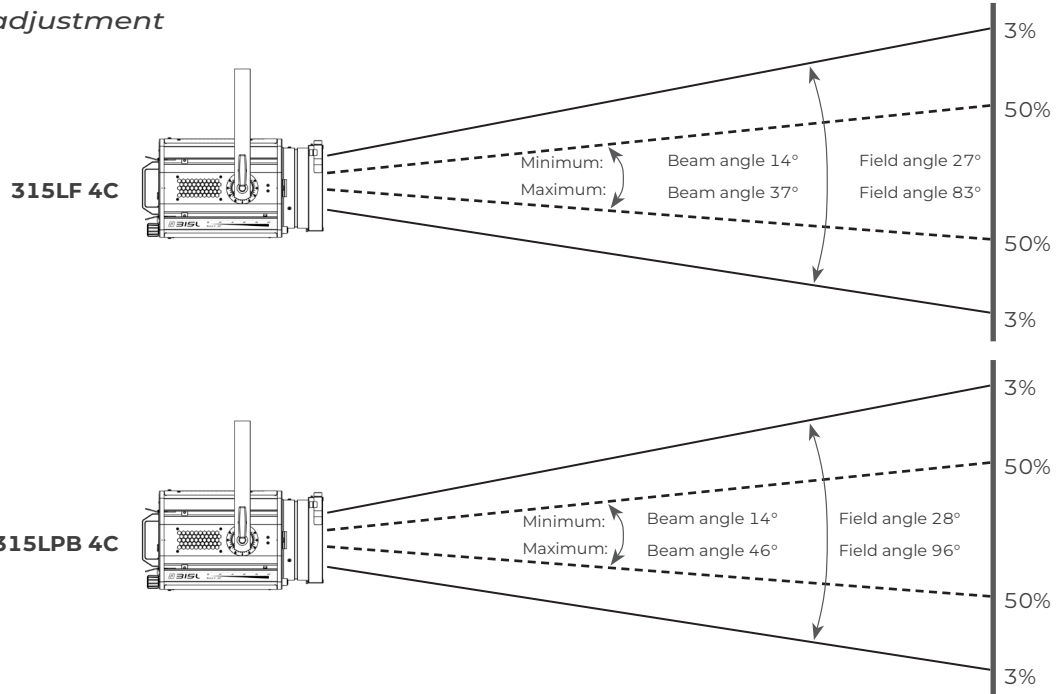

4.10.2 Control

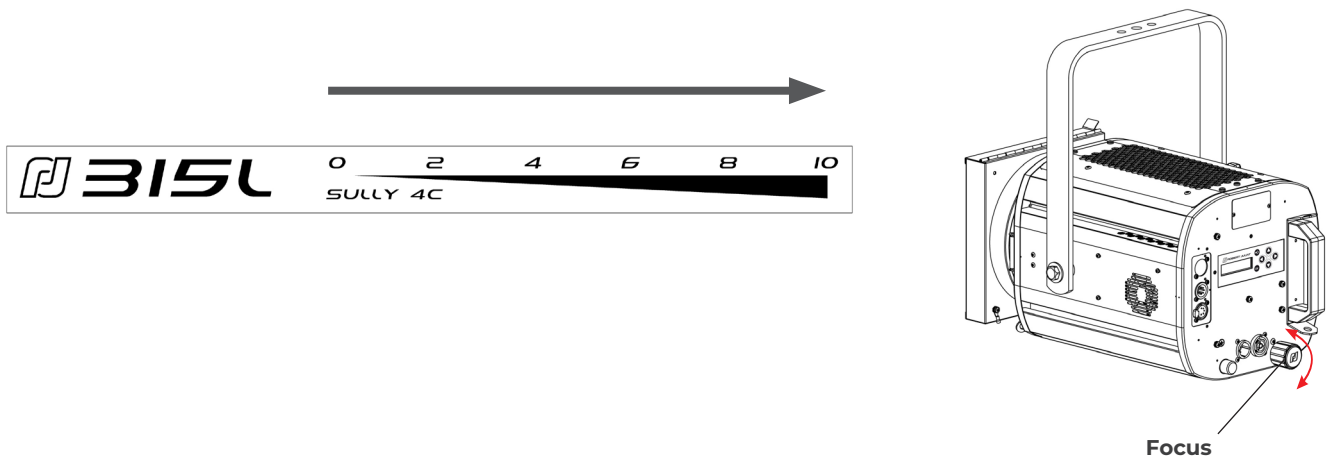

4.11 Orientation

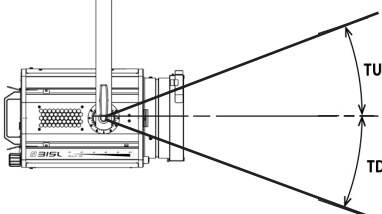

4.11.1 Range

Function	Range
PAN	0 → 360°
TILT	 TU = 0 → 90° TD = 0 → 90°

4.11.2 Control

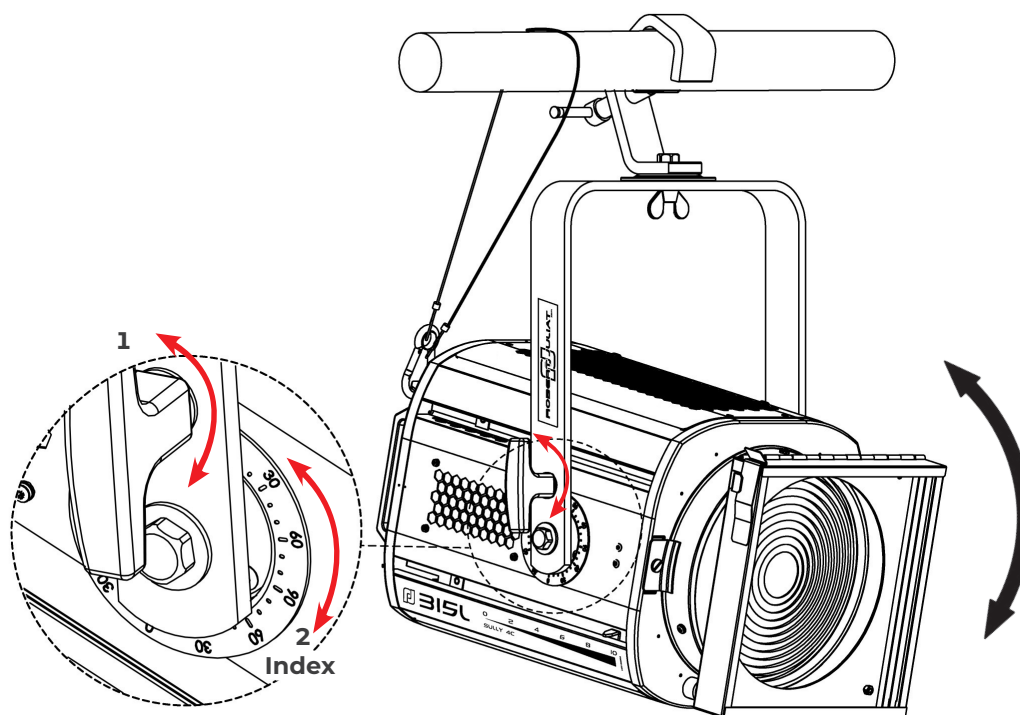

Fixed colour

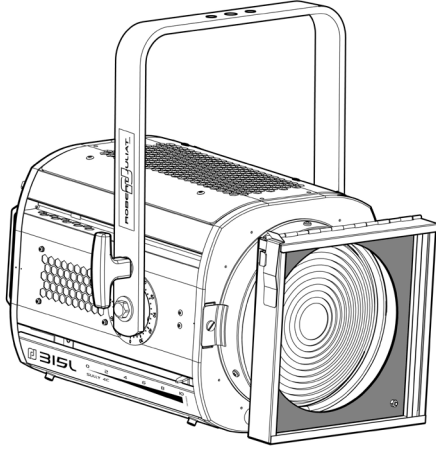
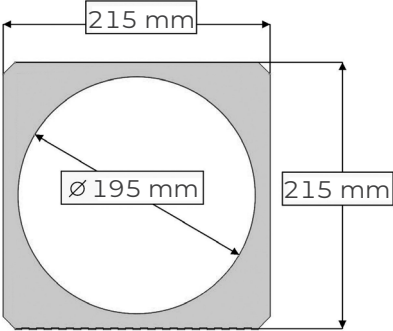
<p>Location</p>	 <p>Front filter holder</p>
<p>Type</p>	<p>Standard coloured gel filter</p>
<p>Dimensions</p>	
<p>Installation</p>	<p>See 3.4.1</p>

4.13 Beam shaping

4.13.1 Range

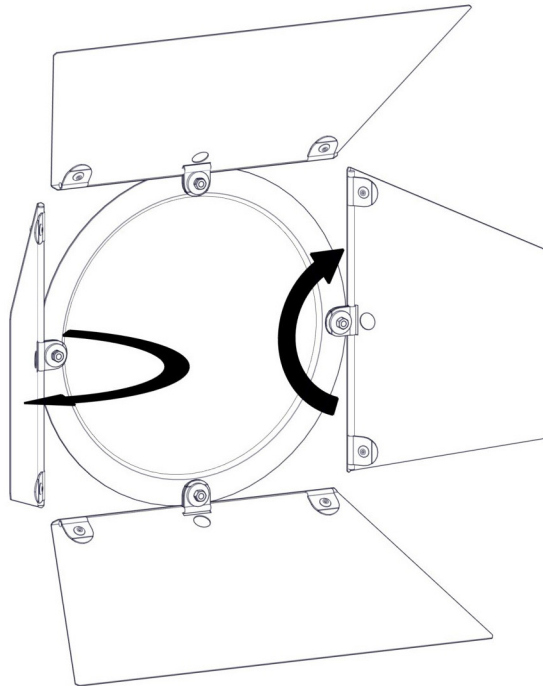

Examples:

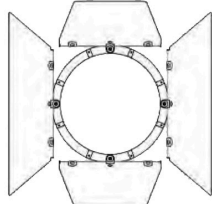
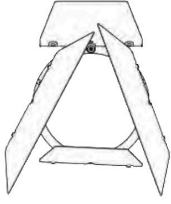
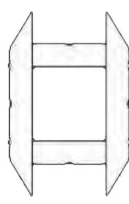
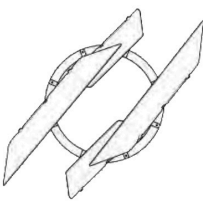
			
Open	Triangle	Square	Line

4.13.2 Control

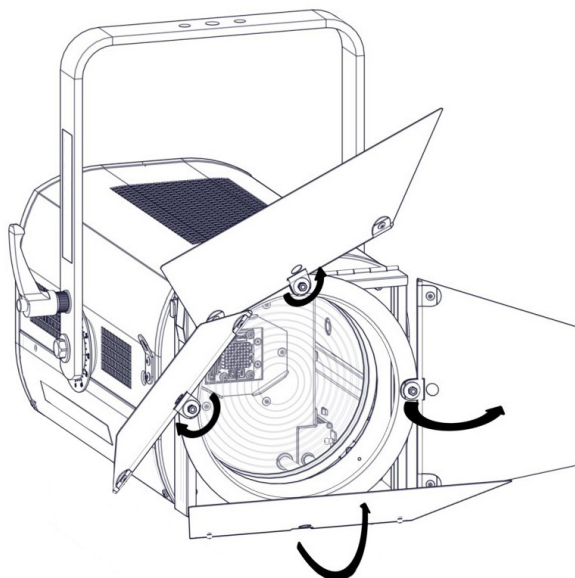

5.1 Local display and controls

5.1.1 Display

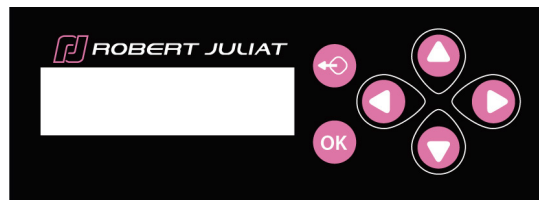

Function	
	Exit the current menu option and/or go back
	Enter the current menu option and/or valid
	Scroll through menus and/or Increase data value
	Scroll through menus and/or Decrease data value
	Menu down and/or Increase data value
	Menu up and/or Decrease data value





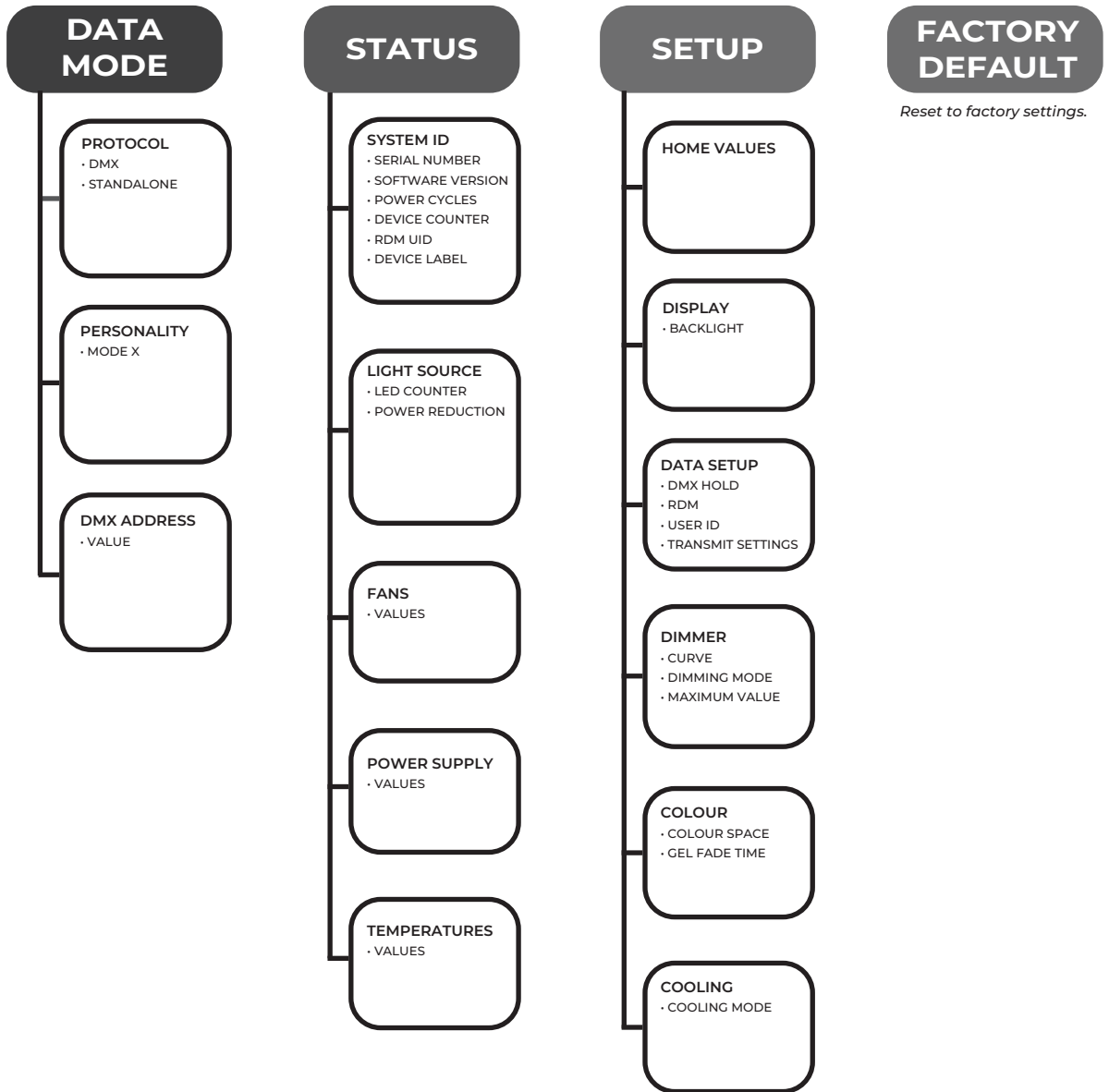

5.1.2 Home screen

Display	Mode	Description
Protocol selected DMX Personality Active mode Source #Gel / Colour Space	Home	Main display (home screen)
FIXTURE STATUS ▶ TEMPERATURE LED 24°C TEMPERATURE DRIVERS 37°C	 x1 push	Fixture Status
PROTOCOL STATUS ▶ DMX ADDRESS 25 RDM ON PERSONALITY FULL-RGB	 x1 push	Protocol Status
ACTIVE VALUES ▶ DIMMER 0.0 % STROBE: DURATION -- ...	 x1 push	Active values

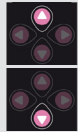

5.1.4.1 Backlight

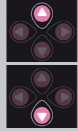
→ Selection in SETUP / DISPLAY / BACKLIGHT menu

Display	Mode	Description
<div style="border: 1px solid black; padding: 5px;"> <p>DISPLAY BACKLIGHT</p> <p>▶ ALWAYS ON AUTO OFF AUTO OFF - ONLY WARNINGS</p> </div>	ALWAYS ON	Main display, always ON   <p>Press OK to validate</p>
<div style="border: 1px solid black; padding: 5px;"> <p>DISPLAY BACKLIGHT</p> <p>ALWAYS ON ▶ AUTO OFF AUTO OFF - ONLY WARNINGS</p> </div>	AUTO OFF	Main display OFF after 20 seconds   <p>Press OK to validate</p>
<div style="border: 1px solid black; padding: 5px;"> <p>DISPLAY BACKLIGHT</p> <p>ALWAYS ON AUTO OFF ▶ AUTO OFF - ONLY WARNINGS</p> </div>	AUTO OFF - ONLY WARNINGS	Main display OFF after 20 seconds, ON if warning information occurs   <p>Press OK to validate</p>

5.2 DMX512 - A remote control

5.2.1 Protocol

E1.11 - 2008, USITT DMX512-A

5.2.2 Configuration

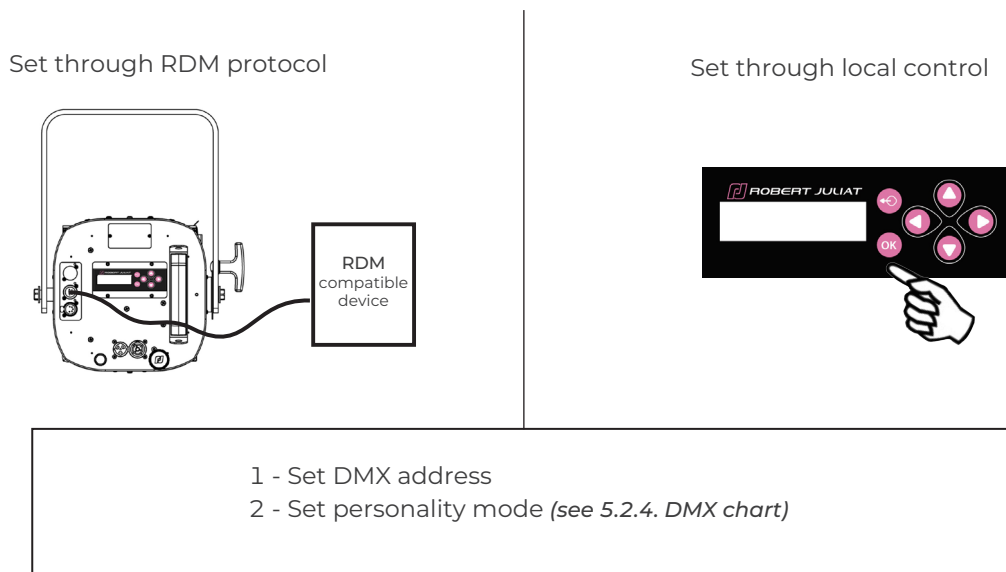

1 - Set DMX mode:

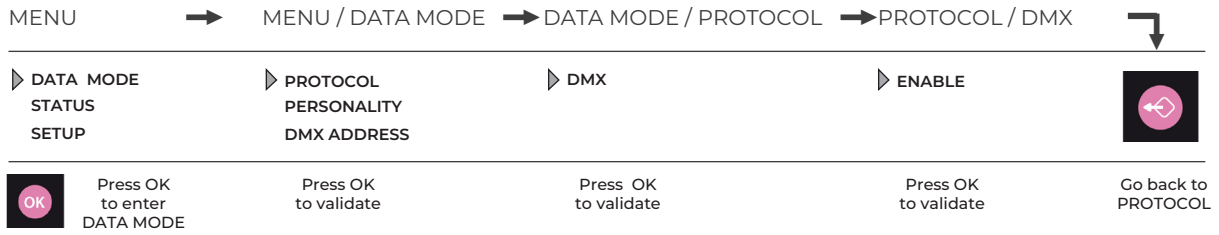

2 - Set Personality mode:

MENU / DATA MODE → DATA MODE / PERSONALITY

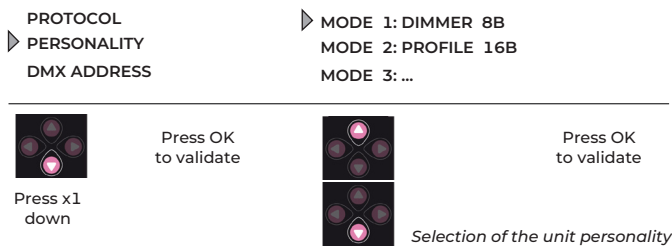

3 - Set DMX address:

MENU / DATA MODE → DATA MODE / DMX ADDRESS

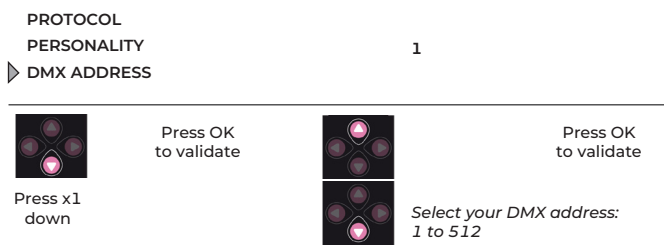

5.2.3 Parameters

5.2.3.1 DMX Hold



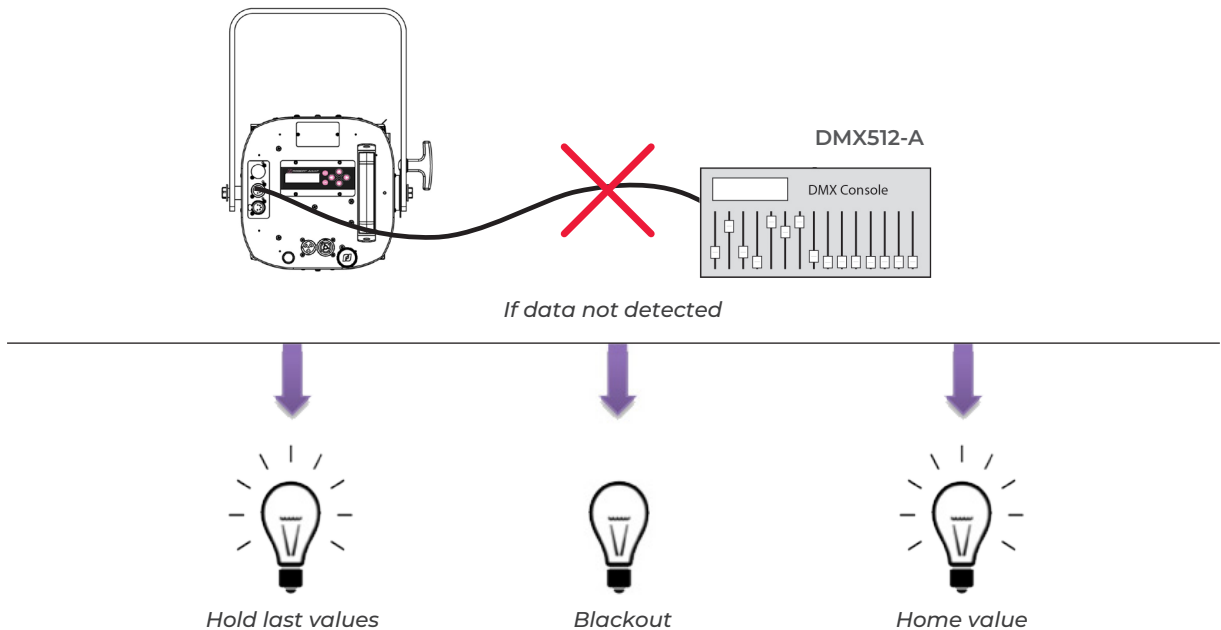



→ Selection in SETUP / Data Setup / DMX HOLD menu



5.2.3.2 User ID

➔ Selection in SETUP / Data Setup / USER ID menu

Each unit can be identified by a User ID number – Once defined, the User ID is displayed on the Home screen.

Example: Installation with 6 units						
Home screen information	ID1 @ 101	ID2 @ 123	ID3 @ 145	ID4 @ 167	ID5 @ 189	ID6 @ 211
User ID	1	2	3	4	5	6
DMX address	101	123	145	167	189	211

5.2.3.3 Transfer settings

➔ Selection in SETUP / Data Setup / TRANSFER SETTINGS menu

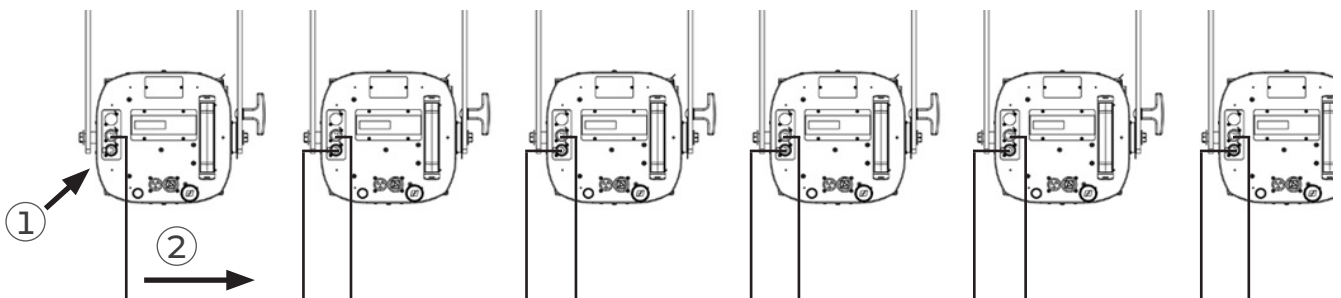

1. Setup of the first unit
2. Transmission of all parameters to the other units connected by DMX

Mode	Function
WITH DMX ADDRESS	Transmission of unit configuration : Data mode + Setup
WITHOUT DMX ADDRESS	Transmission of unit configuration : Data mode (excluding DMX address) + Setup

DMX Channel	Mode 1	Mode 2	Mode 3	Mode 4	Mode 5	Mode 6
	Dimmer8B	Profile16b	Full - XY	Full - HS	Full - RGB	Full - Raw
1	Dimmer	Dimmer	Dimmer	Dimmer	Dimmer	Dimmer
2		Dimmer fine	Dimmer fine	Dimmer fine	Dimmer fine	Dimmer fine
3		Strobe duration	Strobe duration	Strobe duration	Strobe duration	Strobe duration
4		Strobe speed	Strobe speed	Strobe speed	Strobe speed	Strobe speed
5		Response time	Response time	Response time	Response time	Response time
6		Control mode	Control mode	Control mode	Control mode	Control mode
7			Source Type	Source Type	Source Type	Source Type
8			Gel: Type	Gel: Type	Gel: Type	Gel: Type
9			Gel: Reference	Gel: Reference	Gel: Reference	Gel: Reference
10			Gel: Saturation	Gel: Saturation	Gel: Saturation	Gel: Saturation
11			Gel: Transmission	Gel: Transmission	Gel: Transmission	Gel: Transmission
12			Gel: Fade Time	Gel: Fade Time	Gel: Fade Time	Gel: Fade Time
13			Gel: Fade Mode	Gel: Fade Mode	Gel: Fade Mode	Gel: Fade Mode
14			Tunable white: CCT	Tunable white: CCT	Tunable white: CCT	Tunable white: CCT
15			Tunable white: CCT fine	Tunable white: CCT fine	Tunable white: CCT fine	Tunable white: CCT fine
16			Tunable white: Delta UV	Tunable white: Delta UV	Tunable white: Delta UV	Tunable white: Delta UV
17			Colour: X	Colour: Hue	Colour: Red	Colour: Red
18			Colour: X fine	Colour: Hue fine	Colour: Red fine	Colour: Red fine
19			Colour: Y	Colour: Saturation	Colour: Green	Colour: Green
20			Colour: Y fine	Colour: Saturation fine	Colour: Green fine	Colour: Green fine
21					Colour: Blue	Colour: Blue
22					Colour: Blue fine	Colour: Blue fine
23						Colour: Lime
24						Colour: Lime fine

5.2.5 DMX ranges

5.2.5.1 Strobe duration

Range min	Range max	Function
0	0	Strobe OFF
1	255	Strobe ON - 1 ms → 20 ms

5.2.5.2 Strobe speed

Range min	Range max	Function
0	255	Frequency: 0,1 Hz → 10 Hz

5.2.5.3 Response time

Range min	Range max	Function
0	0	Default value: none tungsten source = 120ms tungsten source = 1000 W
1	127	Tungsten 500 W → 5000 W
128	191	Linear 0s → 4s
192	255	Linear 0s → 4s / Flash by-pass

5.2.5.4 Control mode*

Range min	Range max	Function
0	0	
1	10	RDM disabled
11	20	RDM enabled
21	30	Fixture Reset
31	40	Dimmer Curve Linear
41	50	Dimmer Curve Square
51	60	Dimmer Curve Tungsten
61	70	Colour Space Native
71	80	Colour Space sRGB / Rec. 709
81	90	Colour Space Rec. 2020
91	100	Colour Space ProPhoto RGB
101	110	Cooling mode: Silent
111	120	Cooling mode: Normal
121	130	Cooling mode: Full
131	140	Gel Fade Time: x1
141	150	Gel Fade Time: x10
151	160	Gel Fade Time: x100
161	255	Not used

(*) Function activated after 5 seconds - need to go back to zero to activate second function.

5.2.5.5 Source Type

Range min	Range max	Function
0	10	Tungsten 3200 K High Quality - DimShift
11	20	Tungsten 3000 K High Quality - DimShift
21	30	Tungsten 3200 K High Quality
31	40	Tungsten 3000 K High Quality
41	50	Daylight D65 High Quality
51	100	Not used
101	110	Generic CCT - High Quality
111	120	Generic CCT - High Brightness
121	130	Generic CCT - High Quality - DimShift
131	140	Generic CCT - High Brightness - DimShift
141	200	Not used
201	210	Colour Mix - High Quality
211	220	Colour Mix - High Brightness
221	255	Not used

5.2.5.6 Gel Type

Range min	Range max	Function	Gel Type	Comments
0	4	Wheel 1	Basics	Only when Source type = "Calibrated whites" & "Generic CCT"
5	9	Wheel 2	Numeric: 002 --> 111	
10	14	Wheel 3	Numeric: 113 --> 181	
15	19	Wheel 4	Numeric: 182 --> 328	
20	24	Wheel 5	Numeric: 332 --> 710	
25	29	Wheel 6	Numeric: 711 --> 799	
30	34	Wheel 7	Chroma: 048 --> 719	
35	39	Wheel 8	Chroma: 711 --> 504	
40	44	Wheel 9	Chroma: 730--> 007	
45	49	Wheel 10	Chroma: 765 --> 789	
50	54	Wheel 11	Chroma: 787 --> 344	
55	59	Wheel 12	Cosmetic & Corrections	
60	64	Wheel 13	Dalis selection	
65	254			Not used

5.2.5.7 Gel references

➔ See annex for reference details

5.2.5.8 Gel Saturation

Range min	Range max	Function	Comments
0	255	0 ➔ 100%	Only when Source type = "Calibrated whites" & "Generic CCT"

5.2.5.9 Gel Transmission

Range min	Range max	Function	Comments
0	255	0 ➔ 100%	Only when Source type = "Calibrated whites" & "Generic CCT"

5.2.5.10 Gel Fade Time

Range min	Range max	Function	Comments
0	0	0s	
1	255	0,1 ➔ 25,5s	Only when Source type = "Calibrated whites" & "Generic CCT"

Range min	Range max	Mode	Comments
0	10	Direct XY + Limit Brightness	Only when Source type = "Calibrated whites" & "Generic CCT"
11	20	Direct XY	
21	30	Open Frame + Limit Brightness	
31	40	Open Frame	
41	50	Through Black	
51	255	Reserved / Off (0 s)	

5.2.5.12 CCT

Range min	Range max	Mode	Comments
0	255	1700K → 10 000K	Only when Source type = "Generic CCT"

5.2.5.13 DeltaUV

Range min	Range max	Mode	Comments
0	126	Magenta correction: - 100% T 0	Only when Source type = "Generic CCT"
127	127	Black body locus: 0	
128	255	Green correction: 0 → 100%	

5.2.5.14 Colour CIE x

Range min	Range max	Mode	Comments
0	255	y=0 → y=0.85	Only when Source type = "Colour Mix"

5.2.5.15 Colour CIE y

Range min	Range max	Mode	Comments
0	255	y=0 → y=0.85	Only when Source type = "Colour Mix"

5.3 RDM remote control

5.3.1 Protocol

ANSI E1.20 – 2010 / ANSI E1.37 - 1

For more information on the RDM protocol: <http://www.rdmprotocol.org/>

PID	Description	Standard	Get	Set	4C
					b 6262
Network Management					
00 01	DISCOVERY_UNIQUE_BRANCH	E1.20*			✓
00 02	DISCOVERY_MUTE	E1.20		✓	✓
00 03	DISCOVERY_UNMUTE	E1.20		✓	✓
00 15	COMMUNICATION_STATUS	E1.20	✓	✓	✓
Status Collection					
00 31	STATUS_ID_DESCRIPTION	E1.20	✓		✓
00 32	CLEAR_STATUS_ID	E1.20		✓	✓
RDM Information					
00 50	SUPPORTED_PARAMETERS	E1.20*	✓		✓
Product Information					
00 60	DEVICE_INFO	E1.20*	✓		✓
00 80	DEVICE_MODEL_DESCRIPTION	E1.21	✓		✓
00 81	MANUFACTURER_LABEL	E1.20	✓		✓
00 82	DEVICE_LABEL	E1.20	✓	✓	✓
00 90	FACTORY_DEFAULTS	E1.20	✓	✓	✓
00 C0	SOFTWARE_VERSION_LABEL	E1.20*	✓		✓
00 C1	BOOT_SOFTWARE_VERSION_ID	E1.20	✓		✓
00 C2	BOOT_SOFTWARE_VERSION_LABEL	E1.20	✓		✓
DMX512 Setup					
00 E0	DMX512_PERSONALITY	E1.20	✓	✓	✓
00 E1	DMX512_PERSONALITY_DESCRIPTION	E1.20	✓		✓
00 F0	DMX512_STARTING_ADDRESS	E1.20*	✓	✓	✓
Sensors					
02 00	SENSOR_DEFINITION	E1.20	✓		✓
02 01	SENSOR_VALUE	E1.20	✓		✓
02 02	SENSOR_RECORD	E1.20	✓	✓	✓
Dimmer Settings					
03 40	DIMMER_INFO	E1.37-1	✓		✓
03 41	MINIMUM_LEVEL	E1.37-1	✓	✓	✓
03 42	MAXIMUM_LEVEL	E1.37-1	✓	✓	✓
Power / Lamp Settings					
04 00	DEVICE_HOURS	E1.20	✓		✓
04 01	LAMP_HOURS	E1.20	✓	✓	✓
04 02	LAMP_STRIKE	E1.20	✓	✓	✓
04 05	DEVICE_POWER_CYCLE	E1.20	✓		✓
Display Settings					
Control					
10 00	IDENTIFY_DEVICE	E1.20*	✓	✓	✓
10 01	RESET_DEVICE	E1.20		✓	✓

5.3.3 Parameters

RDM: ON/OFF

➔ Selection in SETUP / Data Setup / RDM menu

5.4 Fan cooling modes

5.4.1 Range

Mode	Fan Speed
SILENT	Minimum – constant speed
NORMAL	Regulated – depending on ambient temperature
FULL	Maximum – constant speed

5.4.2 Control

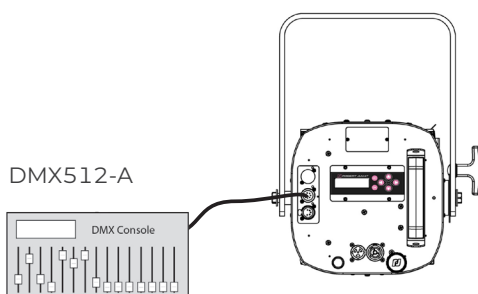

DMX512-A

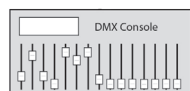

Remotely by DMX512-A
 Mode 2 - 3 - 4 - 5 - 6
 (see 5.2.4 DMX chart for function details)

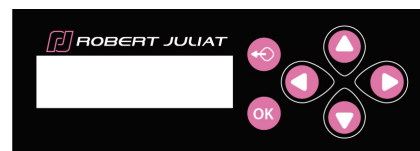

Locally ➔ selection in
 SETUP / COOLING

5.5.1 Trouble shooting

• During unit initialisation (power up) – up to 5 seconds:

1 DMX OUT	2 DMX IN	Description
ⓑ		Error
	Ⓡ	No DMX protocol detected
	ⓐ	DMX protocol detected
	ⓑ	DMX protocol detected + RDM protocol activated

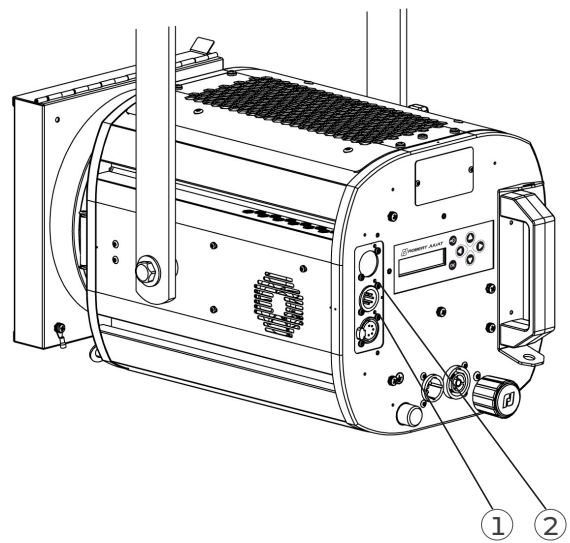

5.5.2 Parameters

5.5.2.1 Auto-OFF

➔ Set through RDM protocol or local control

Mode	Description
Always ON	Feedback LED, always ON
Timer without warning	Feedback LED OFF after 20 seconds ERROR LED always ON
Timer with warning	Feedback LED OFF after 20 seconds ON , if warning information occurs ERROR LED always ON

5.6.1 Range

→ Selection in SETUP / HOME VALUES menu

If the function is not controlled by DMX, HOME VALUE is automatically activated

Functions *	DMX Dimmer mode (mode 1)	DMX Profile mode (mode 2)	DMX Full mode (mode 3-4-5-6)	Stand Alone
Dimmer	DMX value	DMX value	DMX value	Home value
Strobe duration	NA	DMX value	DMX value	NA
Strobe speed	NA	DMX value	DMX value	NA
Response time	Home value	DMX value	DMX value	NA
Control mode	NA	DMX value	DMX value	NA
Source Type	Home value	Home value	DMX value	Home value
Gel: Type	Home value	Home value	DMX value	Home value
Gel: Reference	Home value	Home value	DMX value	Home value
Gel: Saturation	Home value	Home value	DMX value	Home value
Gel: Transmission	Home value	Home value	DMX value	Home value
Gel: Fade time	NA	NA	DMX value	NA
Gel: Fade mode	NA	NA	DMX value	NA
Tunable white: CCT	Home value	Home value	DMX value	Home value
Tunable white: Delta UV	Home value	Home value	DMX value	Home value
Colour: Red	Home value	Home value	DMX value	Home value
Colour: Green	Home value	Home value	DMX value	Home value
Colour: Blue	Home value	Home value	DMX value	Home value
Colour: x	Home value	Home value	DMX value	Home value
Colour: y	Home value	Home value	DMX value	Home value
Colour : Hue	Home value	Home value	DMX value	Home value
Colour: Saturation	Home value	Home value	DMX value	Home value

(*) Functions are displayed depending on DMX mode and Source Type selected
(example : Red, Green, Blue are available if Source Type = Colour Mix)

6.1 Preventive maintenance

6.1.1 Frequency

General maintenance should be performed at least once a year or more frequently if the equipment is operated in adverse conditions (smoke, heat, humidity, touring, etc.).

6.1.2 General cleaning

Remove dust from the unit.

Front glasses can be cleaned with solutions containing alcohol.

6.1.3 General visual check

- No trace of heat.
- No loose contacts.
- No missing parts.
- Tighten mechanical assemblies (screws, bolts and nuts, etc.).

6.1.4 LED source



- Do not touch the surface of the LED source (no contact with your hands or any tools)
 - See section 6.1.7 for the removal and installation procedure of the LED module.
- Do not put compressed air directly on the source.
- Contact a certified RJ distributor in case of residuals or other objects located on the surface of the LED source.

6.1.5 Optics

Only use solutions containing alcohol to clean optical parts (lenses).

- To clean the optical parts, use a soft cloth in combination with distilled water or isopropyl alcohol recommended for coated optics. Do not use any cleaning product that contains solvents or abrasives, as these can cause surface damage.
- Dry with a soft lint-free cloth.

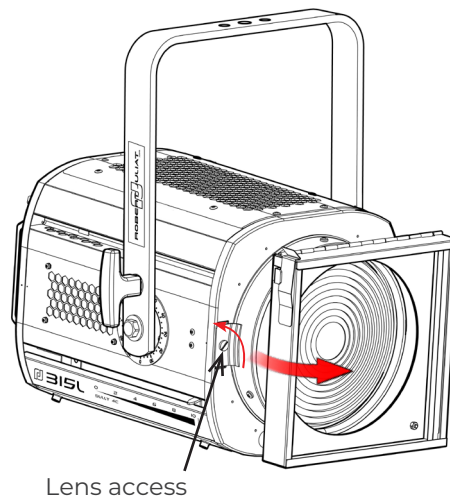

6.1.6 LED house cleaning

Inner parts & lens holder access:

- To clean the optical parts, use a soft cloth in combination with distilled water or isopropyl alcohol recommended for coated optics. Do not use any cleaning product that contains solvents or abrasives, as these can cause surface damage.
- Dry with a soft lint-free cloth.
- The double condenser system (aspheric and biconvex lenses) can easily be removed, without tools, by removing the two M6 nuts. The complete holder can then be removed for cleaning, see section 3.4.2.



In case of problem, contact RJ distributor with the following information:

- Model, version and serial number of the product.
- From the menu status:
 - Software version
 - LED board IDs
 - Device hours
- Description of the problem.

6.3 Electronic thermal management system

In case of overheating, light intensity will be reduced by the system.

Power reduction and temperature values are available by using a RDM protocol compatible device or in the "Status" menu of the fixture.

6.4 Firmware update

A USB/DMX dongle is required and be connected to your PC (no Mac compatibility at the present time) from an USB port to the DMX input of Sully 4C.

USB-Dongle compatibility:

- All Enttec USB-DMX Dongle
- All USB-DMX Dongle based on FTDI chip

Software Platform compatibility:

- Windows 7/8/10

1. Extract the content of folder "Firmware Updater" (including subfolder) to your PC.
2. Connect USB-DMX dongle device via USB to your PC.
3. Connect one or more Fixtures via DMX Cable.
4. Run "RobertJuliat Firmware Updater.exe"
5. The USB-DMX device should be shown in the lower left corner as "Current interface: FTDI FIUP012021..."
If not, click "Interfaces" - "Refresh Interfaces List".
6. Click "Select File" and select the desired update file (*.dmx)
7. Click "Start"
8. All fixtures of the type specified in the update file will automatically enter in Bootloader mode and update their firmware



Product
Updates:



6.5 Factory defaults

6.5.1 Modes

Mode	Description
Factory defaults	Set all user parameters to factory default value

6.5.2 Control

Set to factory defaults /
reset through RDM protocol

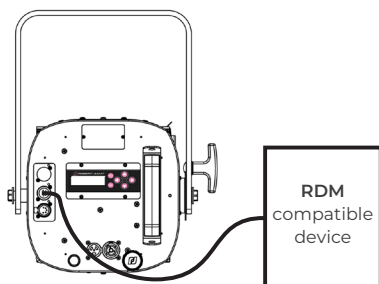

Set to factory defaults /
reset through local control

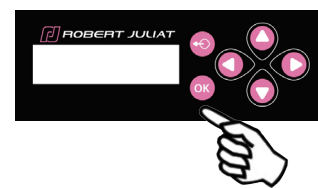

Annex 1 - Gel References

Range #	Range min	Range max	1. Basics	2. Numeric: 002 --> 111	3. Numeric: 113 --> 181	4. Numeric: 182 --> 328	5. Numeric: 332 --> 710	6. Numeric: 711 --> 799	7. Chroma: 048 --> 719	8. Chroma: 711 --> 504	9. Chroma: 730 --> 007	10. Chroma: 765 --> 789	11. Chroma: 787 --> 344	12. Cosmetic & Corrections	13. Dalls selection
1	0	4	Open	Open	Open	Open	Open	Open	Open	Open	Open	Open	Open	Open	Open
2	5	9	2	2	113	182	332	711	48	711	730	765	787	184	203
3	10	14	7	3	115	183	341	712	797	500	242	102	27	185	202
4	15	19	26	4	116	192	343	713	49	501	243	550	29	186	201
5	20	24	27	7	117	193	344	714	126	708	213	513	26	187	200
6	25	29	35	8	118	194	345	715	798	53	246	514	24	188	204
7	30	34	48	9	119	195	352	716	701	502	731	100	157	189	205
8	35	39	88	10	120	196	353	719	345	503	733	10	107	190	206
9	40	44	100	13	121	197	354	721	703	203	245	101	109	191	241
10	45	49	101	15	122	198	363	722	52	600	244	767	176	217	174
11	50	54	105	17	124	199	366	723	704	601	138	104	790	49	161
12	55	59	106	19	126	200	441	724	170	61	88	15	36	65	165
13	60	64	108	20	127	201	442	725	136	63	505	768	192	63	353
14	65	69	115	21	128	202	443	727	169	202	738	179	111	58	079
15	70	74	116	22	130	203	444	728	702	281	121	20	794	172	723
16	75	79	117	24	131	204	500	729	137	201	122	770	2	141	723
17	80	84	118	25	132	205	501	730	194	283	89	105	328	146	119
18	85	89	119	26	134	206	502	731	58	366	139	777	795	130	363
19	90	94	120	27	135	207	503	733	180	174	90	512	128	129	122
20	95	99	122	29	136	208	504	735	343	161	736	652	793	149	124
21	100	104	124	35	137	212	505	736	700	68	740	287	332	104	138
22	105	109	126	36	138	213	506	738	181	132	741	286	148	237	134
23	110	114	128	39	139	218	507	740	707	165	642	204	46	97	147
24	115	119	131	46	140	219	508	741	706	352	643	441	113	240	101
25	120	124	135	48	141	223	511	742	709	143	650	744	127	132	105
26	125	129	138	49	142	230	512	744	142	196	746	285	748	131	328
27	130	134	139	52	143	232	513	746	199	727	653	236	110	176	780
28	135	139	141	53	144	236	514	747	508	141	511	604	247	136	182
29	140	144	144	58	147	237	525	748	799	183	742	651	35	98	026
30	145	149	153	61	148	238	550	763	71	118	208	17	153	102	027
31	150	154	157	63	151	241	600	764	713	724	207	134	4	103	021
32	155	159	164	68	152	242	601	765	710	144	232	147	151	109	102
33	160	164	174	71	153	243	602	767	198	725	230	776	154	108	118
34	165	169	176	75	154	244	603	768	716	117	156	773	248	105	115
35	170	174	179	79	156	245	604	770	195	140	237	108	249	227	197
36	175	179	180	85	157	246	642	773	715	353	747	8	279	233	197
37	180	184	181	88	158	247	643	776	723	172	238	779	3	234	181
38	185	189	182	89	159	248	650	777	721	354	152	158	218	238	139
39	190	194	200	90	161	249	651	778	120	729	162	21	278	235	797
40	195	199	201	100	162	278	652	779	363	116	506	778	159	66	002
41	200	204	202	101	164	279	653	780	85	115	9	780	223	175	Open
42	205	209	203	102	165	281	700	781	119	327	205	22	444	171	Open
43	210	214	204	103	166	283	701	787	722	124	442	135	602	170	Open
44	215	219	205	104	169	285	702	789	79	735	13	781	603	173	Open
45	220	224	206	105	170	286	703	790	714	323	764	25	130	142	Open
46	225	229	219	106	172	287	704	793	75	322	103	507	39	147	Open
47	230	234	244	107	174	322	706	794	525	131	206	19	166	166	Open
48	235	239	245	108	176	323	707	795	197	219	443	164	193	193	Open
49	240	244	332	109	179	325	708	797	712	241	763	182	325	325	Open
50	245	249	702	110	180	327	709	798	200	728	212	106	341	341	Open
51	250	254	738	111	181	328	710	799	719	504	7	789	344	344	Open
52	255	255	Open	Open	Open	Open	Open	Open	Open	Open	Open	Open	Open	Open	Open

Annex 2 - Home values

1. General:





"Home Values" represents a set of parameters manually entered into the device via the keypad in order to restore a predefined setup when a full control of the fixture by DMX is not present, available or allowed. Those home values are used in the following cases:

- ➔ Loss of DMX signal data: From Menu - "Set Up" then "Data Setup" and Select "**DMX Hold**"
- ➔ Standalone Mode : From Menu "Data Mode" then "Protocol" and Select "**Standalone**"
- ➔ 16 bit Personality Mode: From Menu "Data Mode" then "Personality" and Select "**Profile 16 bit**"
- ➔ 8 bit Personality Mode: From Menu "Data Mode" then "Personality" and Select "**Dimmer 8 bit**"

2. Set up the "Dimmer 8 bit" mode:

In "Dimmer 8 bit" mode , the default source is a 3200K halogen source with DimShift (reddening of the filament), halogen dimming curve and a response time corresponding to a 1000W lamp.

BASIC SETUP IN 4 STEPS

Display	Mode	Description
DATA MODE Personality Mode 1 : Dimmer 8 bit		Select Personality Mode: Mode 1 - Dimmer 8 Bit : 1 Channel DMX
DATA MODE DMX address 001 - 512		Select DMX Address
SET UP Home values Gel Type		Select the Color Wheel according to your chosen Gel reference
SET UP Home values Preset colour		Select your Gel reference from the dropdown list

OTHER PARAMETERS AVAILABLE

Display	Mode	Description
SET UP Home values Dimmer Source type Colour mix Response time Tungsten power Gel saturation Gel transmission Tunable white CCT Tunable white delta UV Color Red Color Green Color Blue		All other parameters are available according to the source type selected and technical choices