

TIBO HE

115W LED PROFILE SPOT

Manual

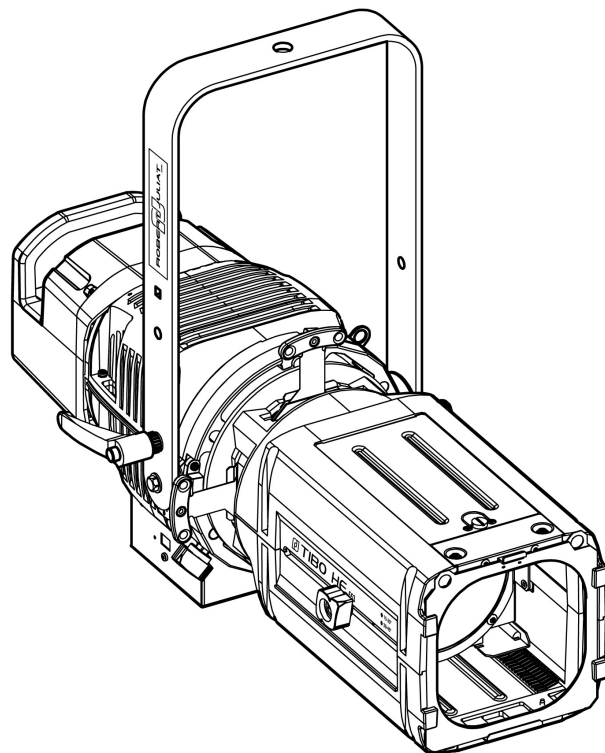

Colour temperature	Standard	North American
COOL WHITE	533 CW	533 CCW
WARM WHITE	533 WW	533 CWW

Product
Updates:



V1

- FIRMWARE: **V5.0x**
- RJ-LED2 FIRMWARE PLATFORM (Node Mode) full manual is
available for download at www.robertjuliat.com/LED/PDF_PAGE

DN41205300-B (EN)

Released: 09/06/26



ROBERT JULIAT

Robert Juliat S.A.S. 32, rue de Beaumont, F 60530 Fresnoy-en-Thelle - phone : +33 (0)3 44 26 51 89 - info@robertjuliat.fr

www.robertjuliat.com

Table of Contents

1	User's instructions	1	5	Controls and parameters	19
2	Presentation	2	5.1	LEDs feedback	19
2.1	Functions	2	5.1.1	Trouble shooting	19
2.2	Identification label	3	5.1.2	Parameters	19
2.3	Accessories included	3	5.1.2.1	Intensity	19
2.4	Accessories	4	5.1.2.2	Auto-OFF	19
3	Set-up	5	5.2	DMX512 - A remote control	20
3.1	Mechanics	5	5.2.1	Protocol	20
3.1.1	Operating positions	5	5.2.2	Configuration	20
3.1.2	Minimum distance between a flammable material	5	5.2.3	Parameters	21
3.1.3	Instructions for use	5	5.2.3.1	DMX Hold	21
3.1.4	Hanging	5	5.2.3.2	Fixture ID	21
3.1.5	Safety cable	6	5.2.3.3	Terminator	21
3.2	Electrical information	6	5.2.3.4	Node	21
3.2.1	LED source	6	5.2.4	DMX charts	22
3.2.2	Power supply	6	5.2.5	DMX ranges	22
3.3	DATA	7	5.2.5.1	Strobe duration	22
3.3.1	DMX 512-A / RDM	7	5.2.5.2	Strobe speed	22
3.3.2	Art-Net / sACN / DUAL	8	5.2.5.3	Response time	22
3.3.3	Ethernet / DMX node / DUAL	8	5.2.5.4	Control mode*	23
3.4	Accessories	9	5.2.6	RDM remote control	24
3.4.1	Front filter holder	9	5.2.6.1	Protocol	24
3.4.2	Iris / Gobo holder	10	5.2.6.2	Functions	24
3.4.3	Shutters	10	5.3	Home values & Standalone	26
4	Operations	11	5.4	Network	26
4.1	Light intensity	11	5.4.1	Art-Net remote control	28
4.1.1	Range	11	5.4.1.1	Protocol	28
4.1.2	Control	11	5.4.1.2	Configuration	28
4.1.3	Parameters	11	5.4.2	sACN remote control	29
4.1.3.1	Dimming resolution - DMX only	11	5.4.2.1	Protocol	29
4.1.3.2	Dimming curve	11	5.4.2.2	Configuration	29
4.1.3.3	Set maximum position	12	5.4.3	Dual remote control	30
4.1.3.4	Dimming mode	12	5.4.3.1	Protocol	30
4.2	Strobe	13	5.4.3.2	Configuration	30
4.2.1	Range	13	5.4.4	Web interface	31
4.2.2	Control	13	5.4.4.1	Control	31
4.3	Response time	13	5.4.4.2	Connection to the Web interface	31
4.3.1	Range	13	5.4.5	LLRP (Low-Level Reader Protocol)	33
4.3.2	Control	13	6	Service	34
4.4	Beam size adjustment	14	6.1	Preventive maintenance	34
4.4.1	Range	14	6.1.1	Frequency	34
4.4.2	Control	14	6.1.2	General cleaning	34
4.5	Orientation	15	6.1.3	General visual check	34
4.5.1	Range	15	6.1.4	LED source	34
4.5.2	Control	15	6.1.5	Optics	34
4.6	Colour	15	6.2	Analysis	35
4.7	Beam shaping	16	6.3	Electronic thermal management system	35
4.7.1	Range	16	6.4	Firmware update	35
4.7.2	Control	16	6.5	Factory defaults	37
4.8	Beam rotation	17	6.5.1	Modes	37
4.8.1	Range	17	6.5.2	Control	37
4.8.2	Control	17	6.6	Testing for errors	37

1 User's instructions

GENERAL INSTRUCTIONS

1. Not for residential use.
2. These fixtures must only be serviced by a qualified technician.
3. In addition to the instructions indicated on this page, relevant health and safety requirements of the appropriate EU Directives must be adhered to at all times.
4. This fixture is in compliance with section 17 - Lighting appliance for theatre stages, television, cinema and photograph studios.
Standards NF EN 60598-1, NF EN 60598-2-17, Low Voltage Directive 2014/35/UE & EMC Directive 2014/30/UE.
5. This fixture is rated as IP20, and is for indoor use only.

FIXTURE

6. Ensure fixture is correctly mounted on an appropriate support.
7. Protection screens and lenses must be replaced in the event of any damage, such as cracks or deep scratches, since these might reduce performance.
8. When hung or flown the fixture must be secured by an additional hanging accessory (such as a safety cable or bond) of suitable length.
9. Safety bonds or cables must be securely attached to the back of the fixture and be as short as possible, or rolled up as necessary, to minimise travel distance should the fixture be dislodged.
10. Movable accessories (scroller, etc.) must also be secured with a suitable safety cable or bond at the front of the fixture.
11. The combined weight of both the fixture and the accessories must be considered when choosing the load-bearing capability of safety cable or bond.
12. Do not open lighting fixture when the source is on.
13. WARNING: LED source becomes hot during use. Allow fixture to cool before servicing.
14. Do not tamper with design of fixture nor any of its safety features.
15. Tighten electrical mains cable connections regularly and replace with one of identical specification if damaged.
16. Use only with correct power supply.

VENTILATION

17. Keep well away from flammable material.
18. Not for outdoor use. Do not cover. Do not permit fixture to get wet.
19. To avoid overheating, do not obstruct air vents.
20. Ensure any cooling fans are in correct working order. If fans are not working, turn fixture off immediately and service as necessary.

CLEANING

21. Do not touch the LED source with your fingers.
22. To clean the optical parts, use a soft cloth in combination with distilled water or isopropyl alcohol recommended for coated optics. Do not use any cleaning product that contains solvents or abrasives, as these can cause surface damage.
Dry with a soft lint-free cloth.
23. Regularly remove dust with a soft lint-free cloth.
24. If the fixture has filters, they must be cleaned frequently.

POWER SUPPLY

25. Disconnect from the mains before servicing.
26. Mains connection only. Do not connect to "electronic output" such as dimmer.
27. Ensure power supply circuit breakers, always remain accessible.

PLEASE NOTE

This product has been built to conform to European standards relating to professional lighting equipment. Any modification made to our products will void the manufacturers' warranty.

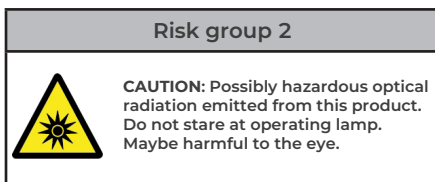

Risk group 2. Luminaires should be positioned so that prolonged staring into luminaire at a distance closer than 12,4 m (40.68 ft) is not expected.

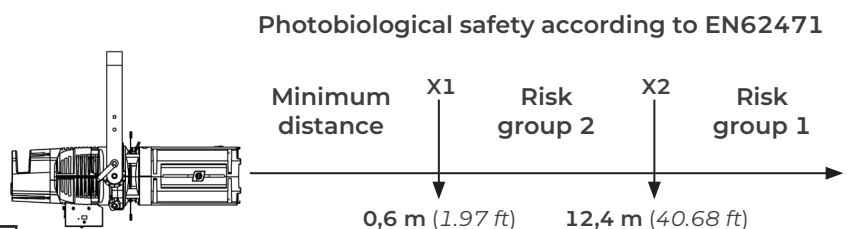

2.1 Functions

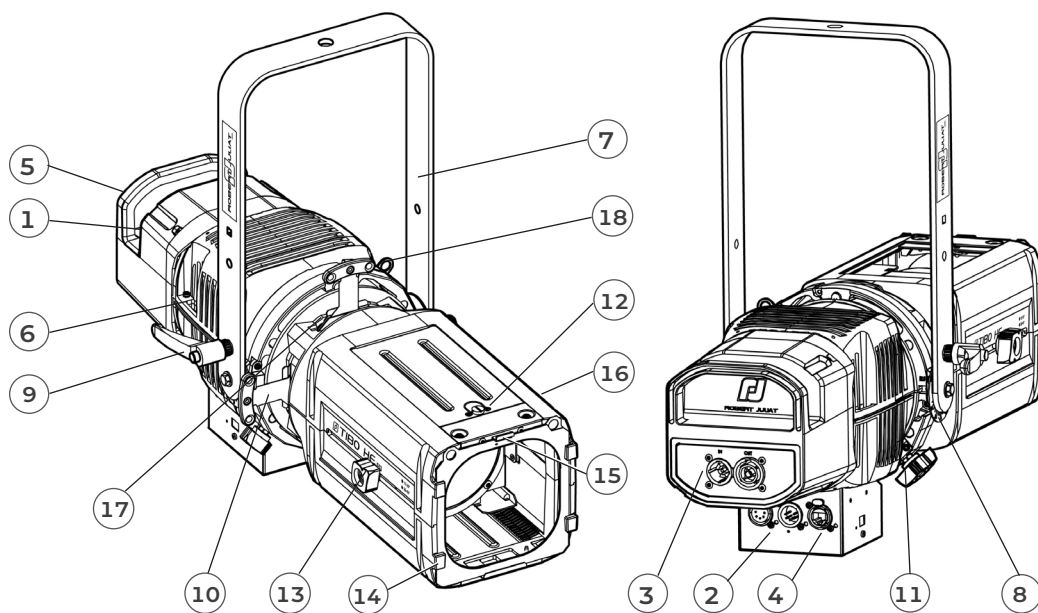

Description

- | | |
|---|---|
| <ul style="list-style-type: none"> 1. Identification plates 2. Data connector (IN and OUT) 3. Power connector (IN and OUT) 4. RJ45 network connector 5. Handle 6. Safety cable attachment point 7. Hanging yoke 8. Tilt index 9. Tilt locking handle 10. Shutters | <ul style="list-style-type: none"> 11. Fixture rotation locking button 12. Lens tube access 13. Zoom adjustment 14. Front slot for accessories and gel frame holder 15. Front slot locking system 16. Focus adjustment 17. Gate slot for gobo holder / iris 18. Safety cable attachment point for accessories |
|---|---|

2.2 Identification label

Description	
	<ol style="list-style-type: none"> 1. MOD.: Model 2. VERS.: Version 3. U : Nominal voltage input (V) 4. I: Nominal intensity (A) 5. P : Maximum power input (W) 6. IP : International Protection Rating 7. t°a : Maximum ambient temperature (°C) 8. t°c : Maximum external temperature of the unit (°C) 9. Net weight (kg) 10. Minimum distance between a flammable material and the lighting unit (m) 11. Colour temperature version 12. Serial number 13. Replace broken glass 14. Class 1 product label 15. Read manual first label 16. European conformity label 17. WEEE directive label 18. CEI-TR-62778 - Do not stare at light source 19. EN62471 - Risk group 20. UKCA (UK Conformity Assessed) label
<p>Units:</p> <ul style="list-style-type: none"> - Weight = kilogram (kg). - Intensity = Ampere (A). - Voltage = Volt (V). - Frequency = Hertz (Hz). - Temperature = degree Celsius (°C). 	

2.3 Accessories included

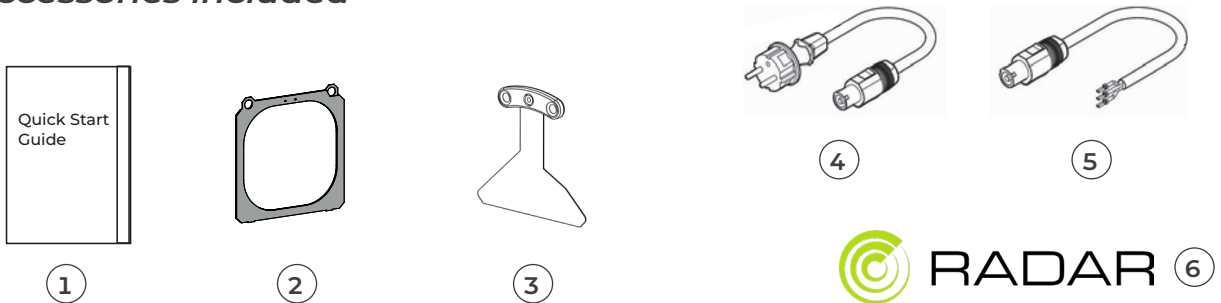

	Reference	Description
1	DN41202200	Quick Start manual
2	PF100M	135x135 mm metal filter holder
3	D4	Shutter for Tibo series
4	CAL03	3 meter power cable (3G1,5 HO7RNF) with Neutrik PowerCon® True1 TOP and CEE 7/7 (2P+T NF/SCHUKO) connectors (standard version)
5	CAL04	1,50m power cable UL/CSA with Neutrik PowerCon® True1 TOP connector (North American version)
6	Fusion/RJ	Madrix Radar (RDM monitoring): Fusion RJ licence - access to all RDM parameters of RJ fixtures

MADRIX RADAR – more information: www.robortjuliat.com/RDM-Tools/Madrix_Radar

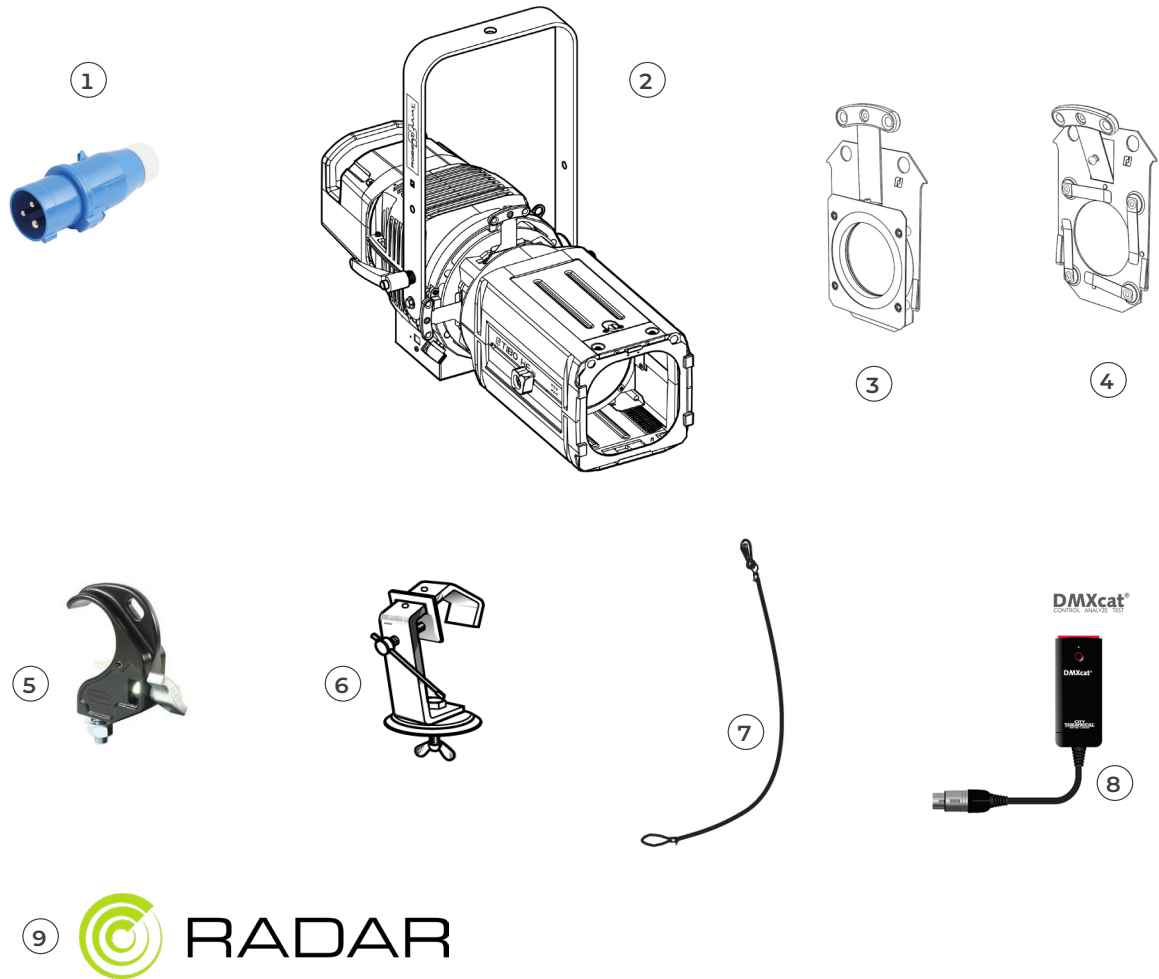

	Reference	Description
1	PCP1716A	16A blue 2P+E 6h IEC60309 power connector
2	T-RAL9010	White housing (RAL 9010)
3	IS500/2	Drop-in iris (monoplane) with holder
4	SGUT	Universal "M" size gobo-holder (metal, glass, frosted glass)
5	872	Doughty "Twenty clamp" with M10 screw/nut for Ø48 to 51mm pipes - SWL: 20Kg - TÜV approved - Weight: 0.25 Kg
6	878	Hook clamp 25x6mm with 23mm M10 screw for Ø35 to 50mm pipes - SWL: 11Kg - Weight: 0.46 Kg
7	CS2	Safety cable Ø3 mm L= 600mm - SWL: 75 Kg
8	DMXcat	Bluetooth DMX/RDM Multifunction test tool - City Theatrical DMXcat®
9	Fusion/S	Madrix Radar (RDM monitoring): Fusion Small licence - up to 64 non-RJ RDM fixtures - USB dongle included
	Fusion/M	Madrix Radar (RDM monitoring): Fusion Medium licence - up to 512 non-RJ RDM fixtures - USB dongle included
	Fusion/L	Madrix Radar (RDM monitoring): Fusion Large licence - up to 4096 non-RJ RDM fixtures - USB dongle included

MADRIX RADAR – more information: www.robertyuliat.com/RDM-Tools/Madrix_Radar

3 Set-up

3.1 Mechanics

3.1.1 Operating positions

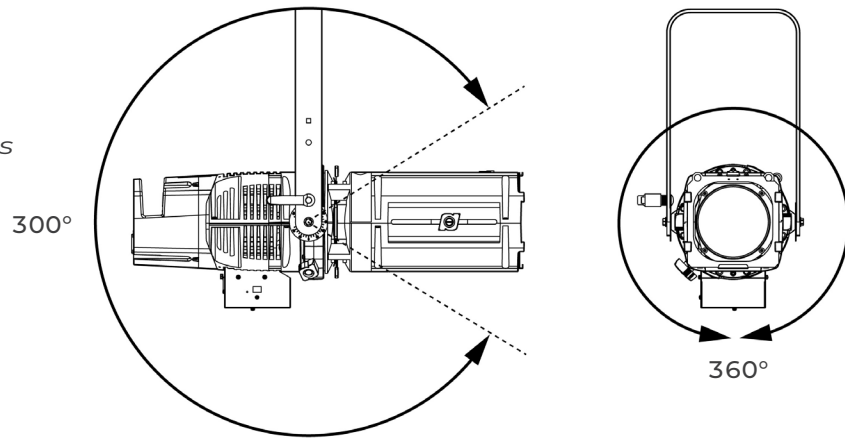

3.1.2 Minimum distance between a flammable material and the lighting unit

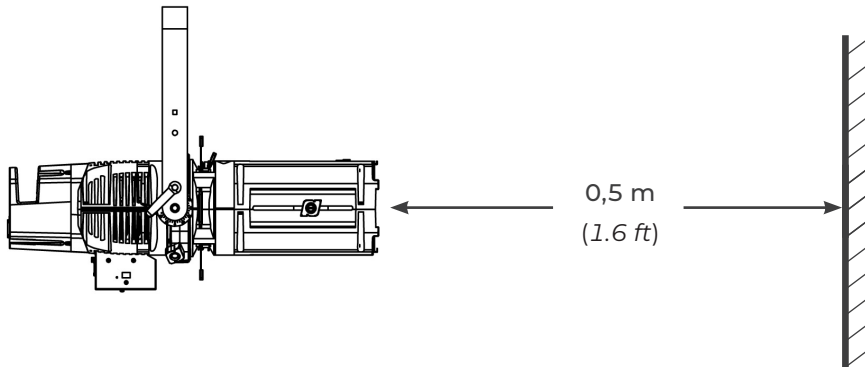

3.1.3 Instructions for use

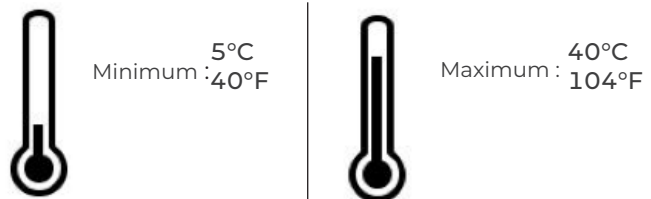

IP20 - Indoor use only

3.1.4 Hanging

- Ensure fixture is correctly mounted on an appropriate support

Net weight:
10,2 kg (22.4 lbs)

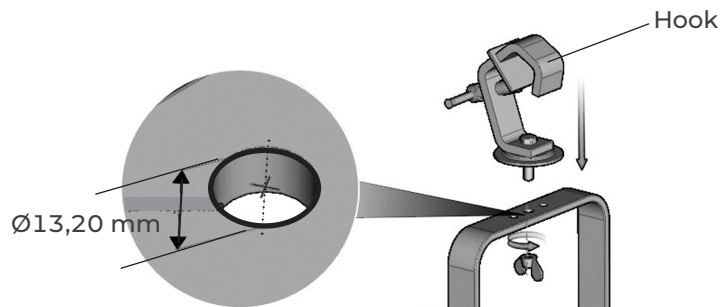

3.1.5 Safety cable

- When hung or flown the fixture must be secured by an additional hanging accessory (such as a safety bond or cable) of suitable length.
- The combined weight of both the fixture and the accessories must be considered when choosing the load-bearing capability of safety cable or bond.
- Safety cables or bonds must be securely attached to the back of the fixture and be as short as possible, or rolled up as necessary, to minimise travel distance should the fixture be dislodged.

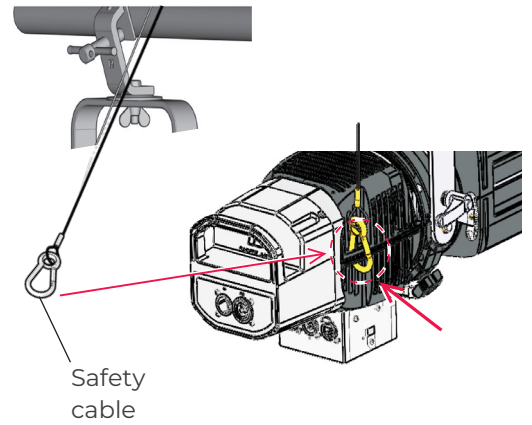

3.2 Electrical information

3.2.1 LED source



Never touch or scratch the LED surface.
See 6.1.4 LED cleaning procedure if cleaning is necessary.

3.2.2 Power supply

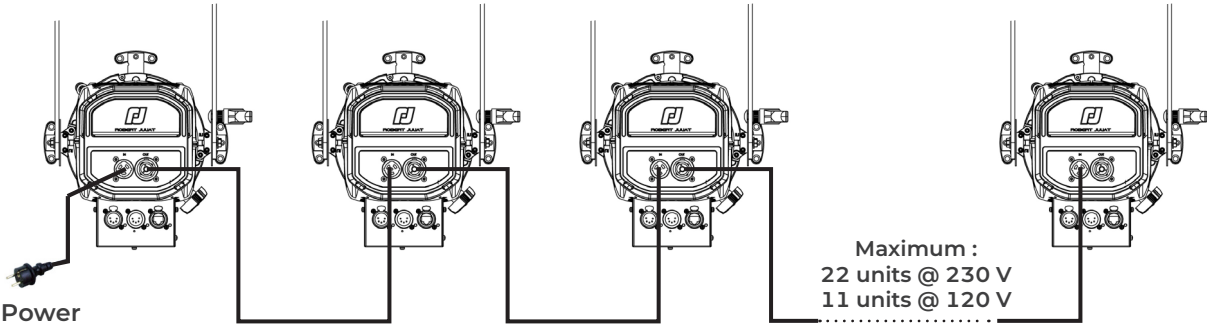
Power supply			
Voltage	Frequency	Input power	Connectors
90 → 277 V	50-60 Hz	0.7 A / 130 W @ 230 V 1.2 A / 135 W @ 120 V 1.4 A / 135 W @ 100 V Max: 1.5 A Standby mode: 10 W	Neutrik powerCON TRUE1 TOP Input : ref. NAC3FPX-TOP
 <ul style="list-style-type: none"> • Class 1 product. This luminaire must be earthed. • Must be connected directly to AC power. Do not connect to dimmer power. • Automatic mains voltage detection. 			
<p>Daisy chain (with delivered power cable):</p>  <p>Maximum : 22 units @ 230 V 11 units @ 120 V</p>			

Power cable

Power cable		Connector	Mains plug	Cable type	Cable length	Wiring
1	Standard version	Neutrik® powerCON TRUE1 TOP NAC3FX-W-TOP	CEE7/7	3G1.5 H07RNF	3 m 9.8 ft	Live: Brown Neutral: Blue Ground: Yellow/Green
2	North American version		-	14AWG SJ TYPE (UL/CSA)	1.5 m 4.9 ft	Live: Black Neutral: White Ground: Green

3.3 DATA

3.3.1 DMX 512-A / RDM

Protocol	Input connector	Output connector
USITT DMX 512-A RDM	XLR 5-pin	XLR 5-pin

DATA connectors			
PIN #	DMX	Description	
1	Shielding	Foil & Braided Shield	
2	DMX (-)	1st conductor of 1st twisted pair	
3	DMX (+)	2nd conductor of 1st twisted pair	
4	Not used	1st conductor of 2nd twisted pair	
5	Not used	2nd conductor of 2nd twisted pair	

Daisy chain:

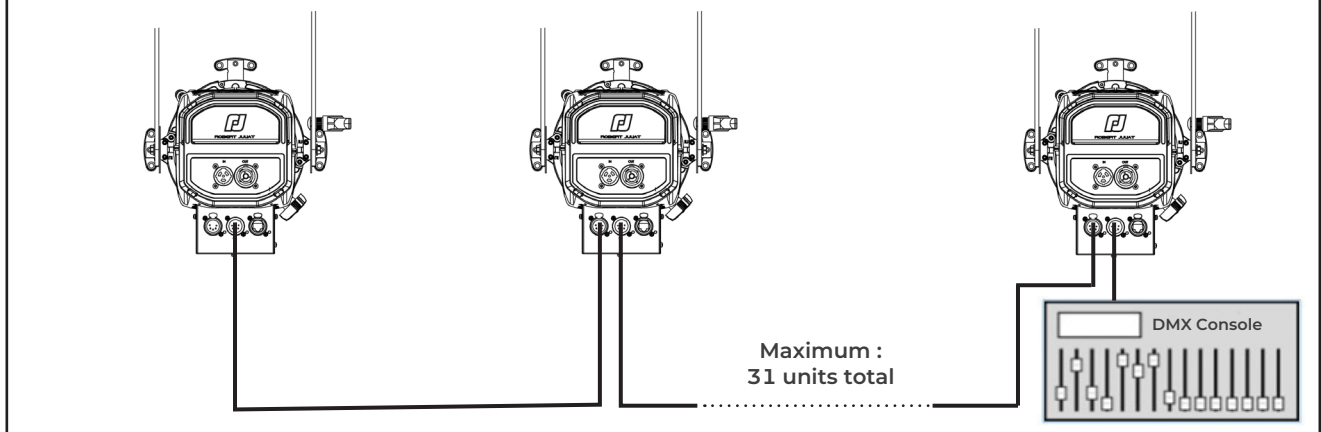

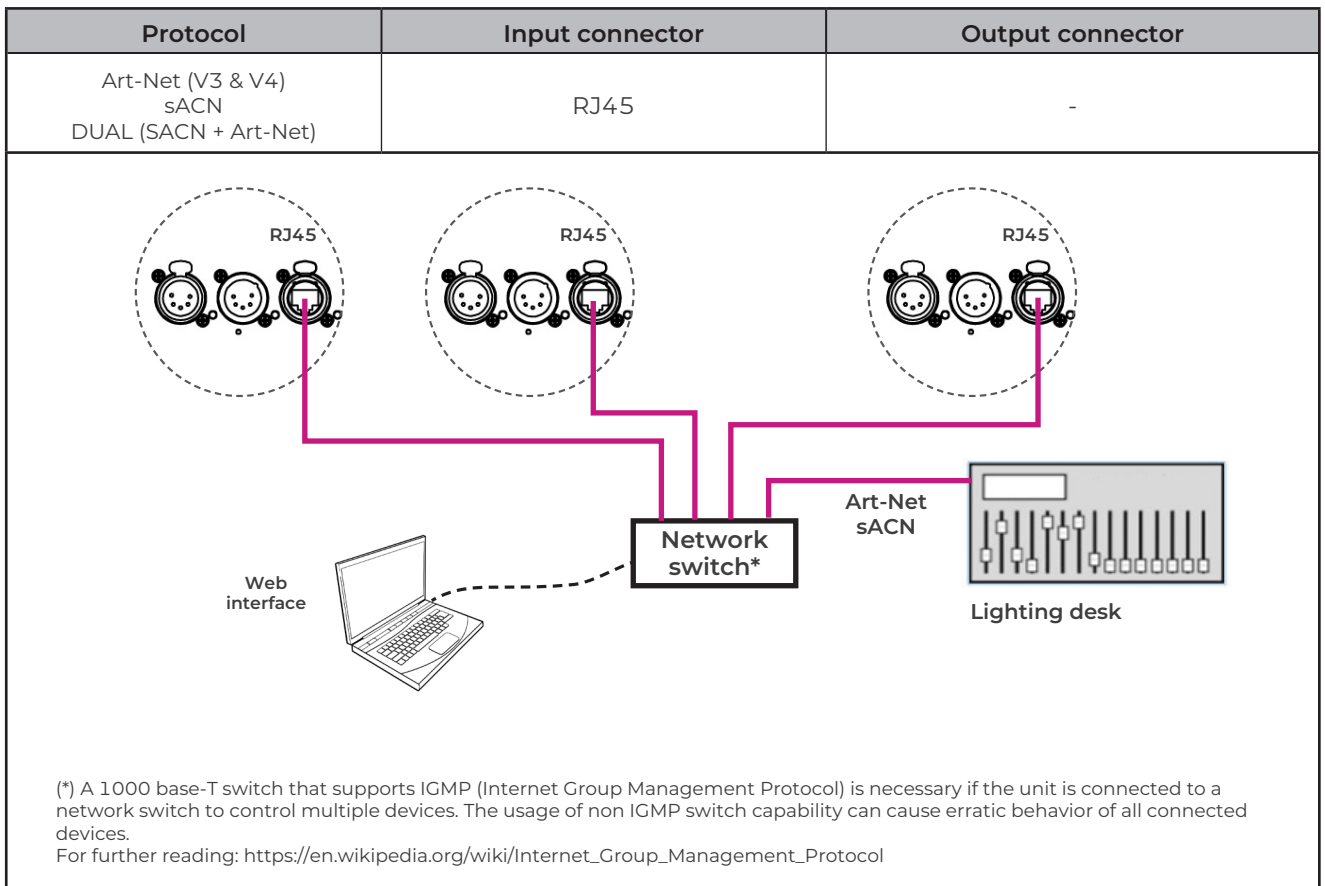

3.3.3 Ethernet / DMX node / DUAL

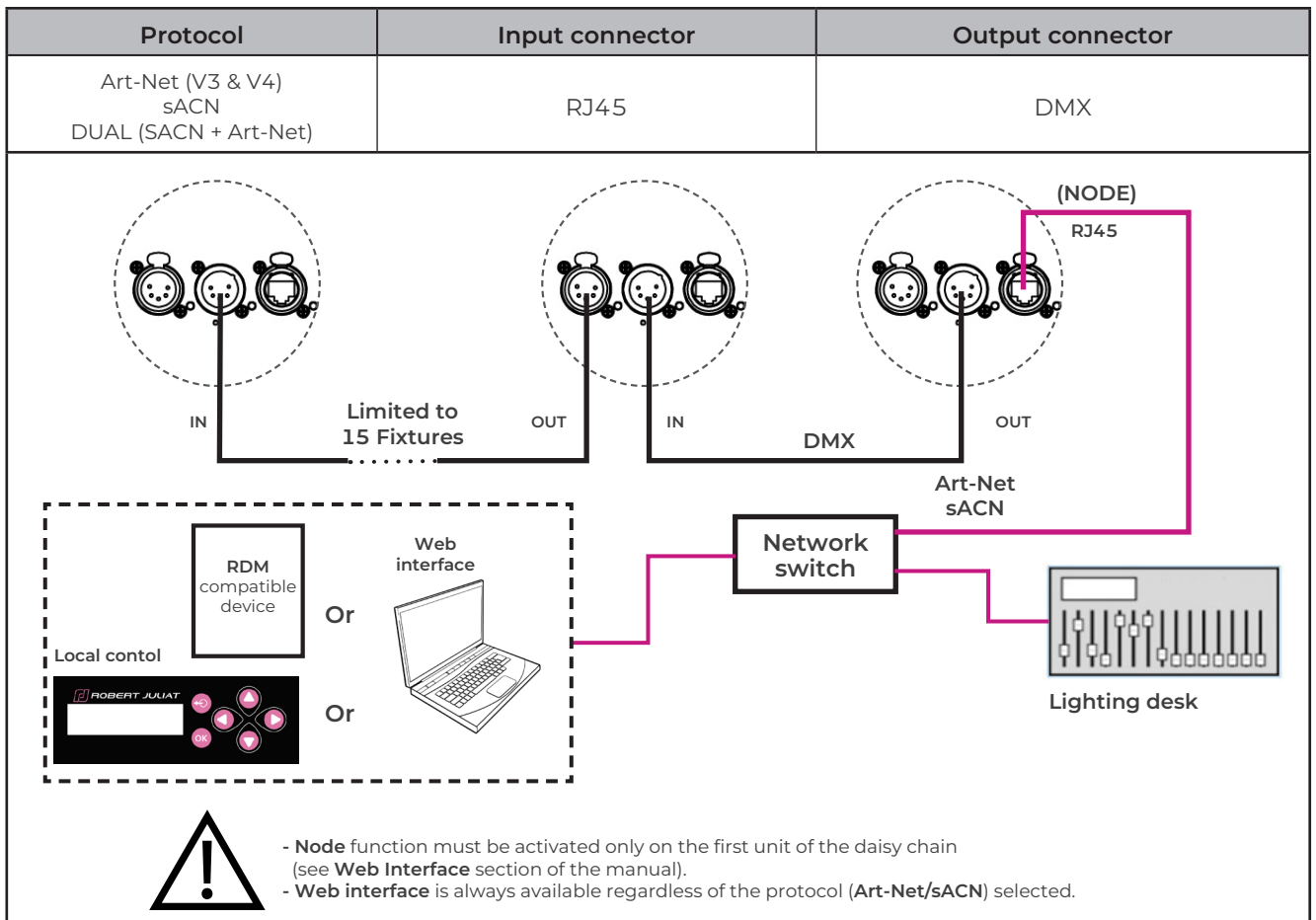

RJ-LED2 FIRMWARE PLATFORM (Node Mode) full manual is available for download at www.robertjuliat.com/LED/PDF_PAGE

3.4 Accessories

3.4.1 Front filter holder

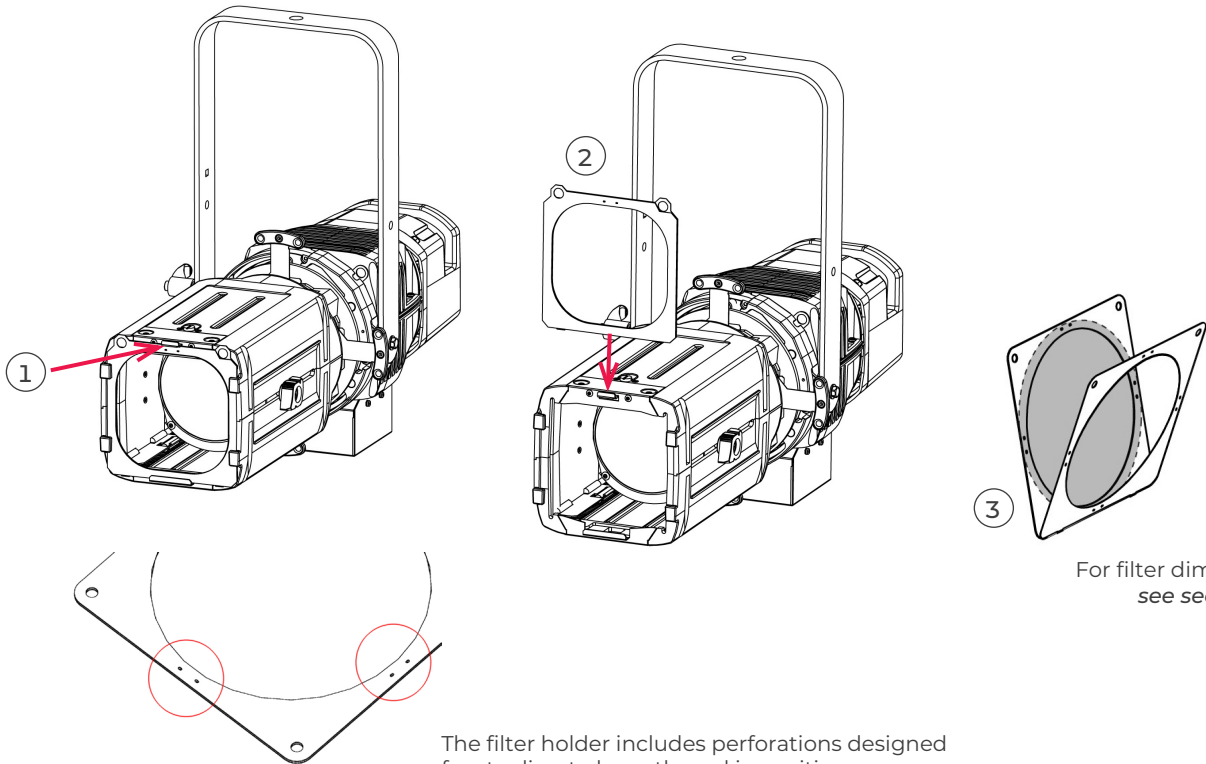

For filter dimensions,
see section 4.6

3.4.2 Iris / Gobo holder

For gobo/Iris dimensions,
see section 4.9

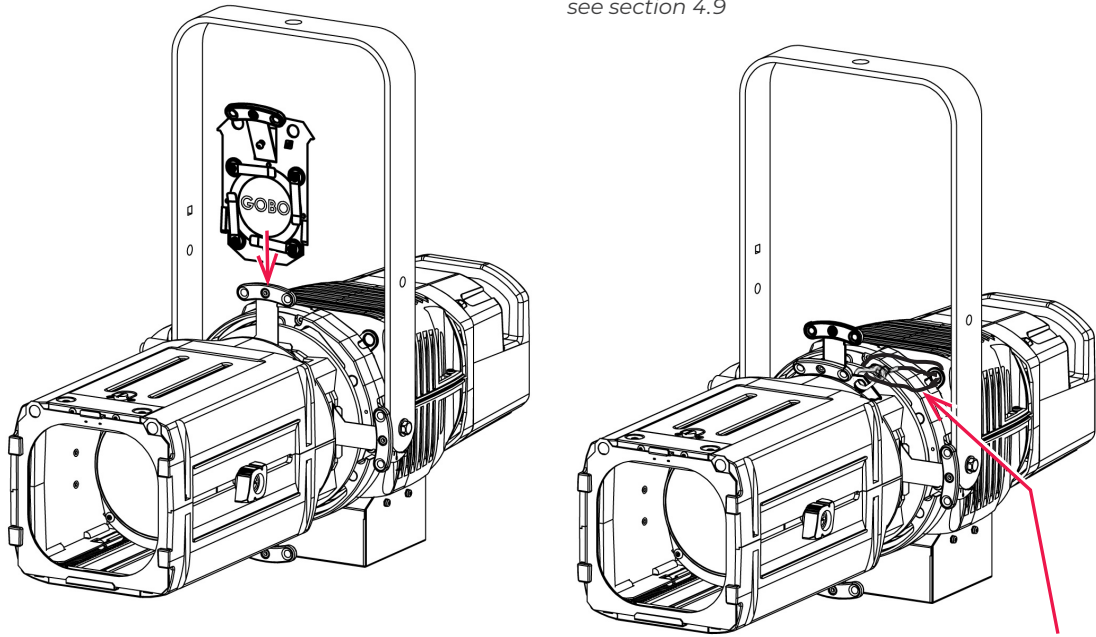

To prevent objects from falling when the fixture is used upside-down,
secure the iris/gobo with a safety cable (ref# CS5)

3.4.3 Shutters

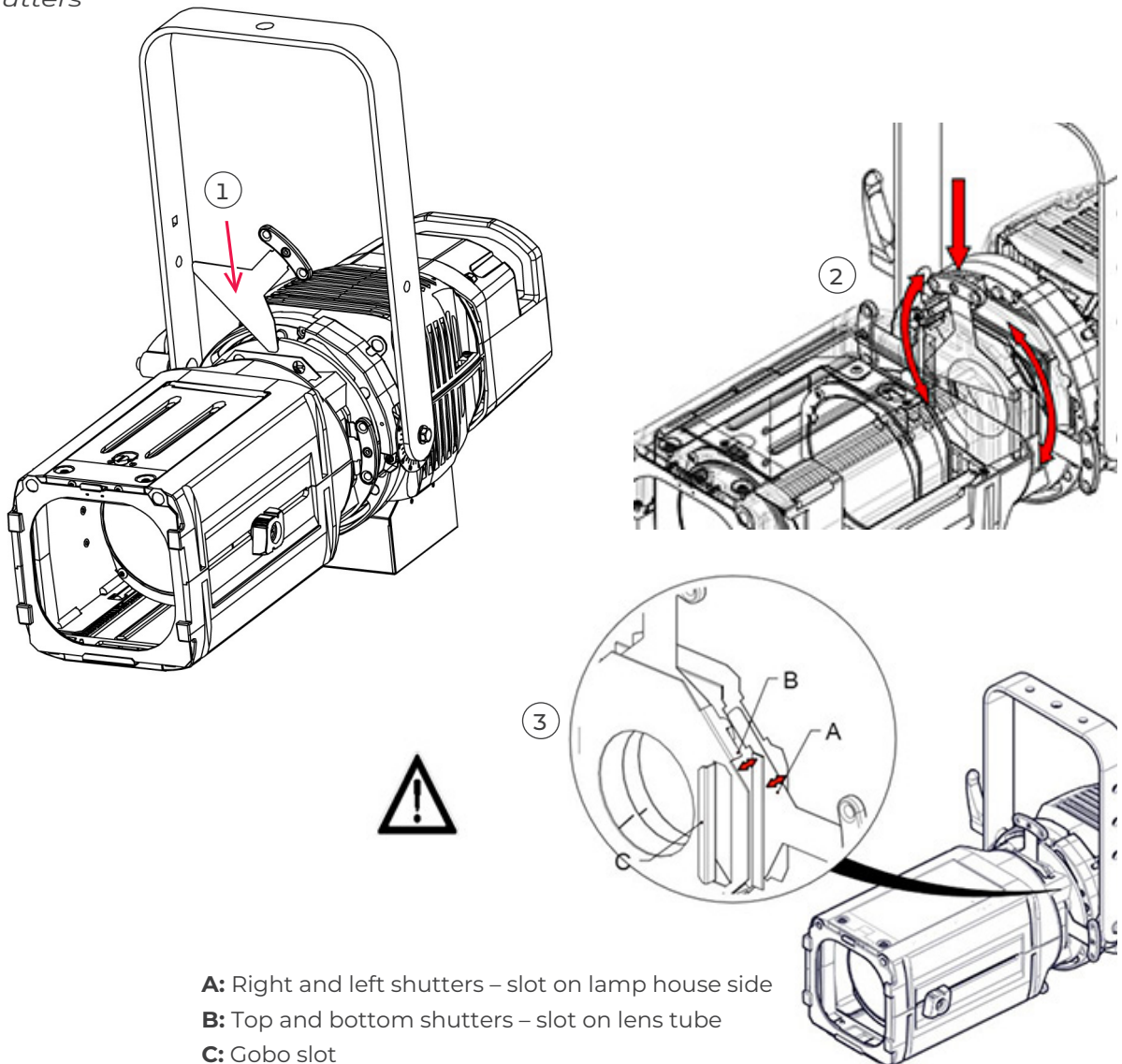

4.1 Light intensity

4.1.1 Range



4.1.2 Control

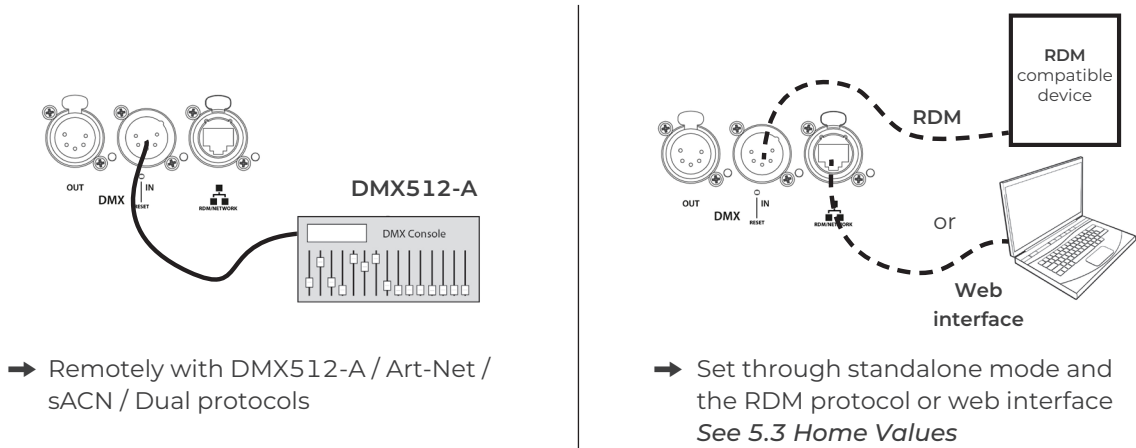

4.1.3 Parameters

4.1.3.1 Dimming resolution - DMX only

→ Set through RDM protocol, web interface or local control

Resolution	DMX mode
8 bits – 255 steps	1 & 3
16 bits – 65 535 steps	2 & 4

4.1.3.2 Dimming curve

→ Set through RDM protocol, web interface or local control

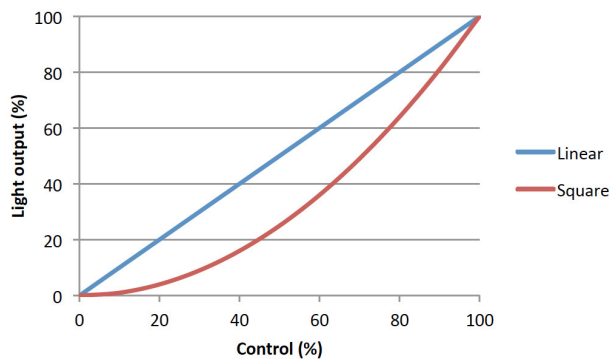

4.1.3.3 Set maximum position

→ Set through RDM protocol, web interface or local control

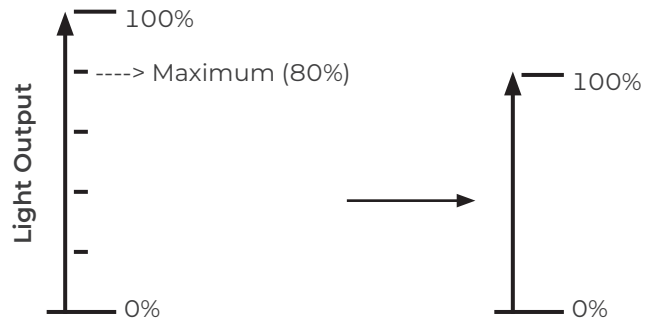

4.1.3.4 Dimming mode

→ Set through RDM protocol, web interface or local control

Mode	Result
Without PWM	Flicker-Free, perfect for filming
PWM 17 kHz	Good dimming quality (Default Value)
PWM 3,2 kHz	Very good dimming

4.2 Strobe

4.2.1 Range

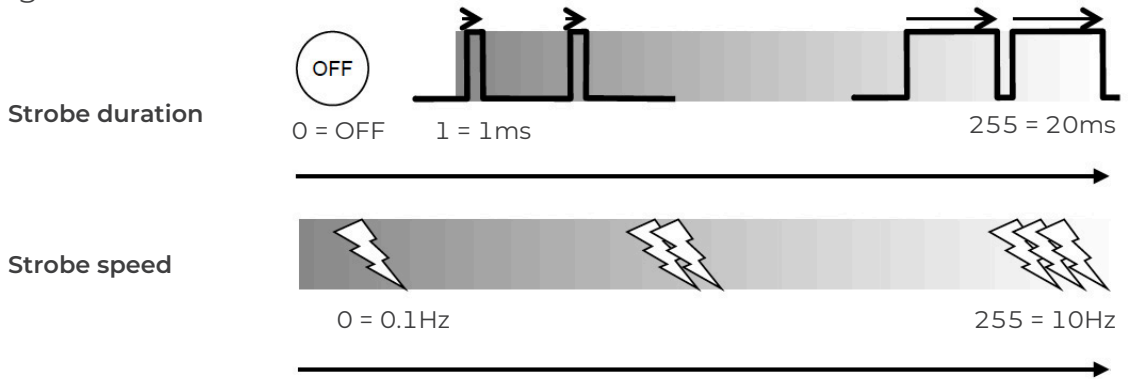

4.2.2 Control

→ Remotely with DMX512-A / Art-Net / sACN / Dual protocols.
 Mode 3 & 4

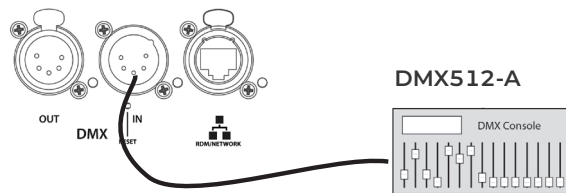

4.3 Response time

4.3.1 Range

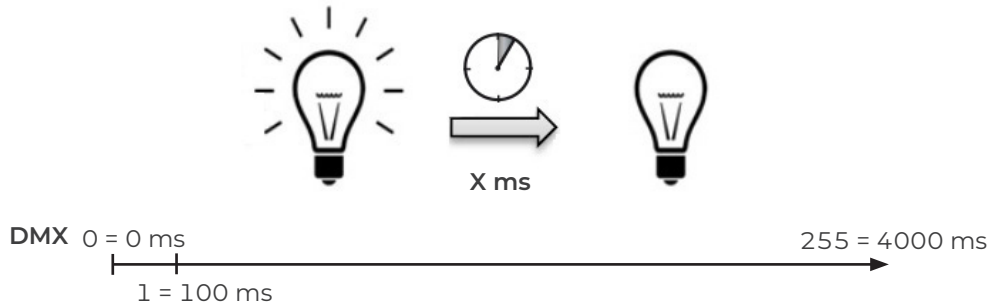

4.3.2 Control

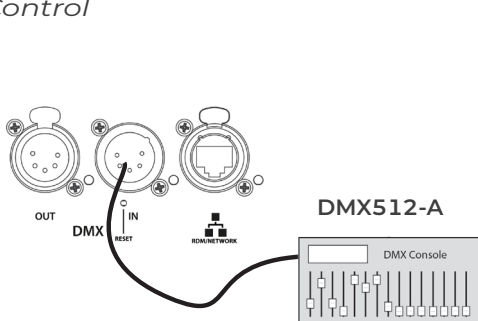

Remotely, with
 DMX512-A / Art-Net / sACN / Dual protocols
 Mode 3 & 4 only

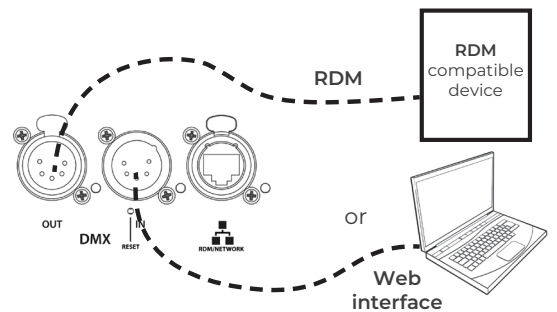

→ Set through RDM protocol or web interface

Mode	Speed
RAW	OFF
SLOW	700 ms
MEDIUM	470 ms
FAST	350 ms
CUSTOM	0 - 4000 ms

See
 5.3 Home Values

4.4 Beam size adjustment

4.4.1 Range

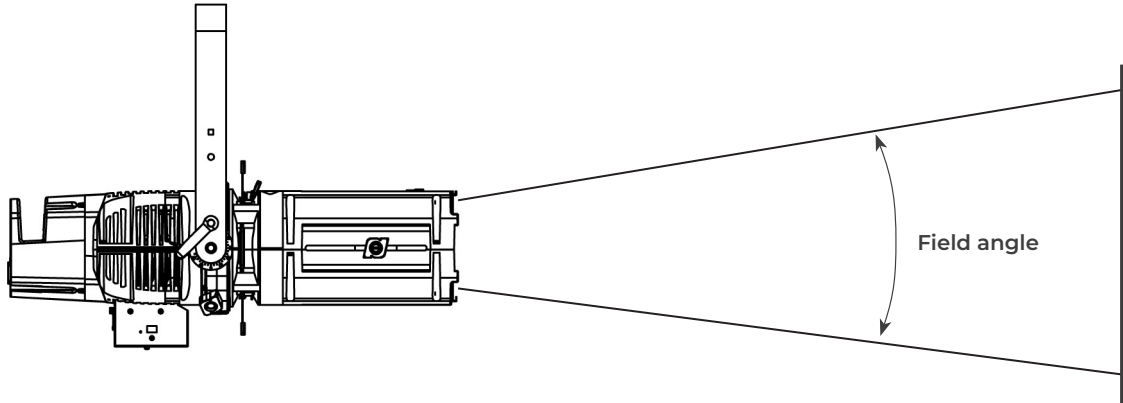

Model	Minimum angle	Maximum angle
Configuration 1 without additional lens	15°	35°
Configuration 2 with additional lens*	30°	45°

(*) Standard delivery

4.4.2 Control

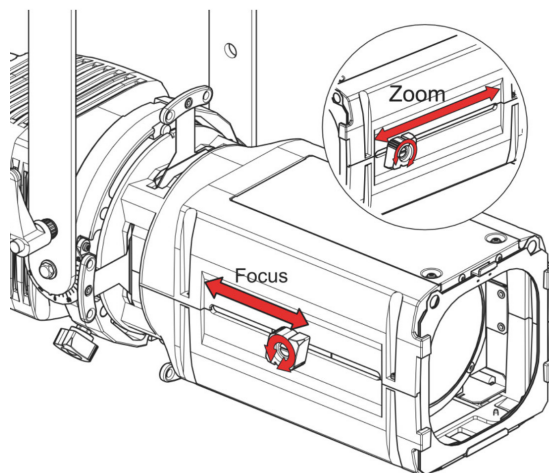

Configuration 2 → configuration 1 :

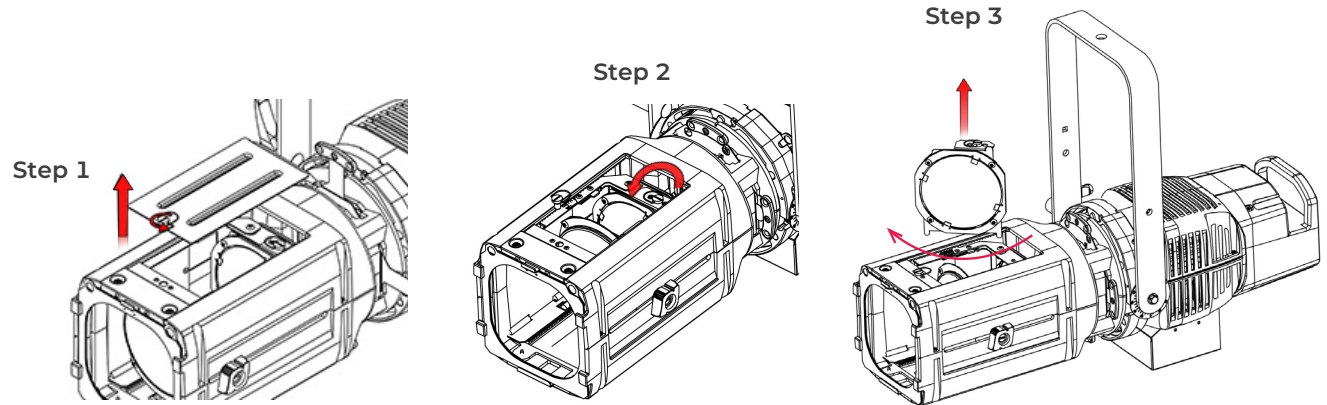

4.5 Orientation

4.5.1 Range

Function	Range
PAN	0 → 360°
TILT	TD = 0 → 90°

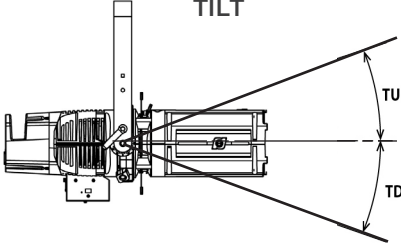

4.5.2 Control

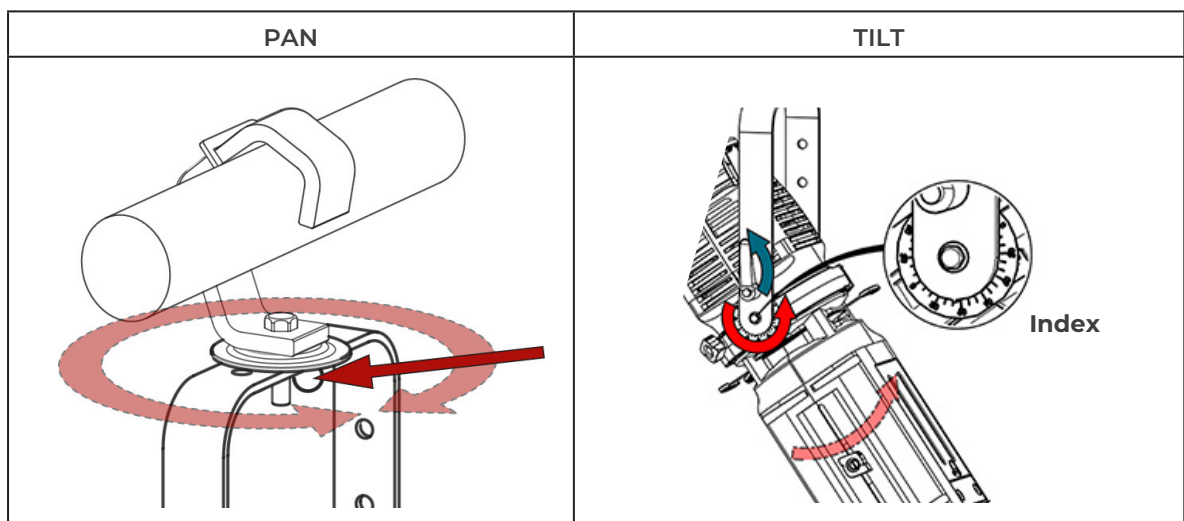

4.6 Colour

Fixed colour:

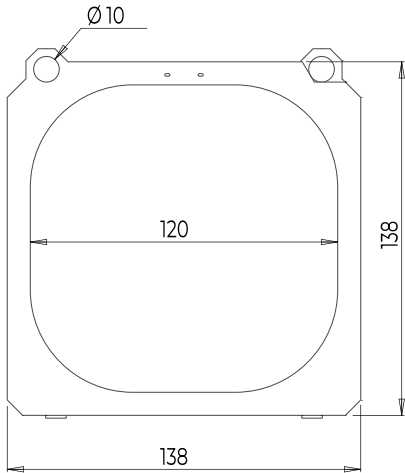
Type	Standard coloured gel filter
Dimensions	 <p>Values are in mm</p>
Installation	See section: 3.4.1

4.7 Beam shaping

4.7.1 Range

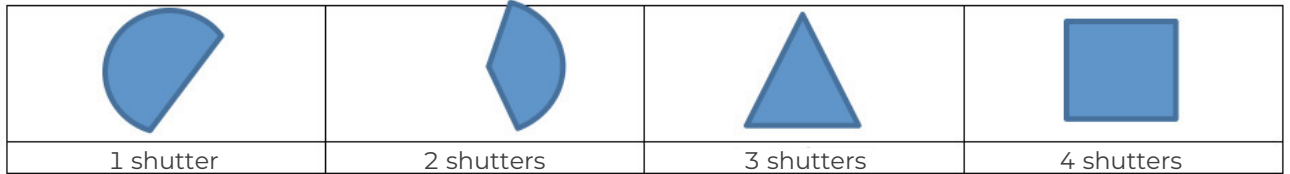
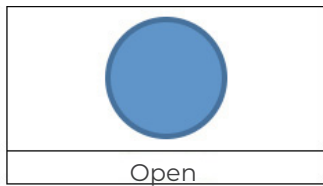

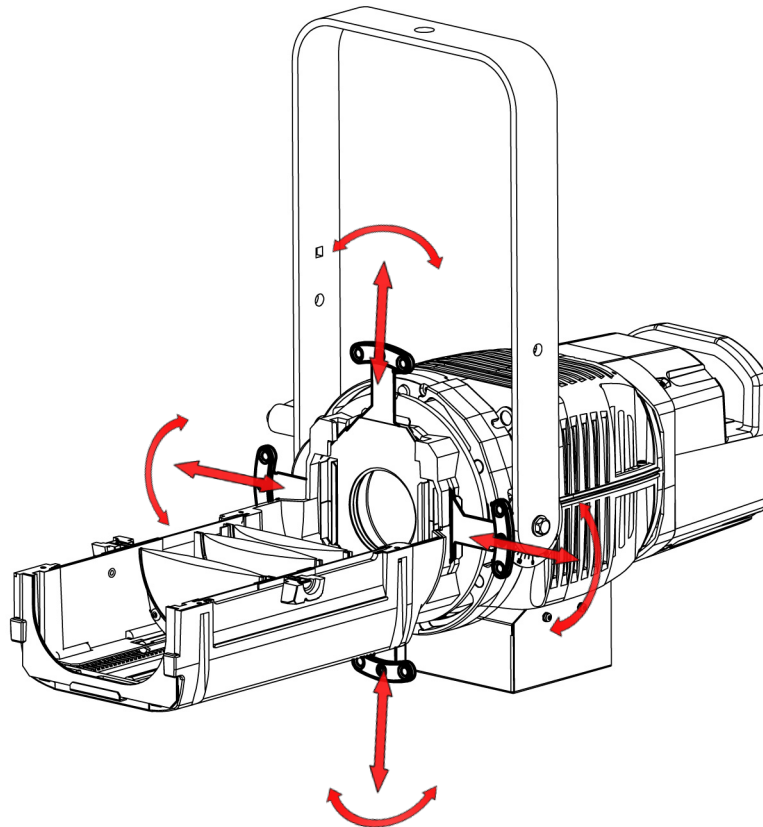

4.7.2 Control



4.8 Beam rotation

4.8.1 Range

Function		Range
		
Gobo	Shutters	

4.8.2 Control

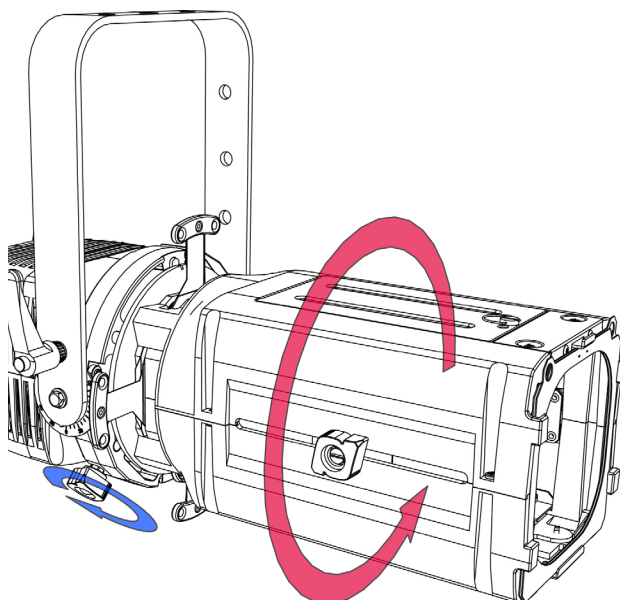

4.9 Gobo and Iris

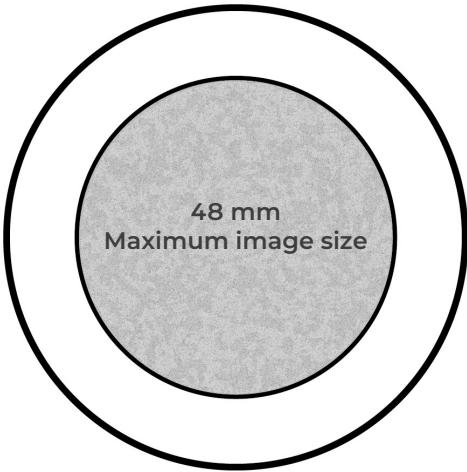

4.9.1 Gobo

Type	Standard gobo - M size
Dimensions	 <ul style="list-style-type: none"> • Metal • Glass <p style="text-align: right;">Values are in mm</p>
Installation	See section: 3.4.2

4.9.2 Iris

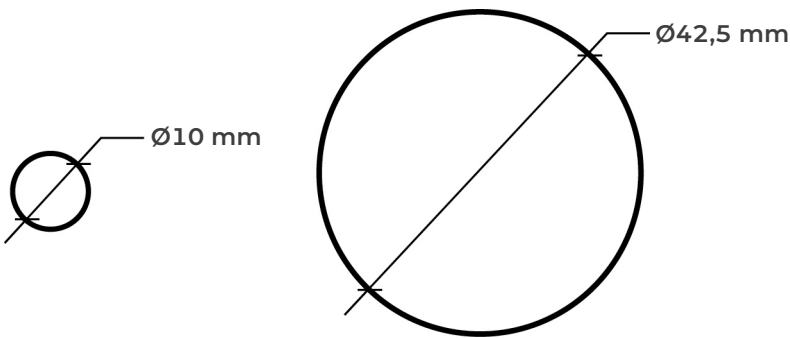
Type	Standard iris
Dimensions	
Installation	See section: 3.4.2

5 Controls and parameters

5.1 LEDs feedback

5.1.1 Trouble shooting

• During unit initialisation (power up) – up to 5 seconds:

1 DMX OUT	2 DMX IN	3 Network	Description
Ⓟ	Ⓟ	Ⓟ	Unit OFF
Ⓡ	Ⓡ	Ⓡ	Unit error
Ⓢ	Ⓢ	Ⓢ	Unit has been reset successfully
Ⓟ	Ⓟ	Ⓡ or Ⓢ or Ⓟ	RDM protocol activated

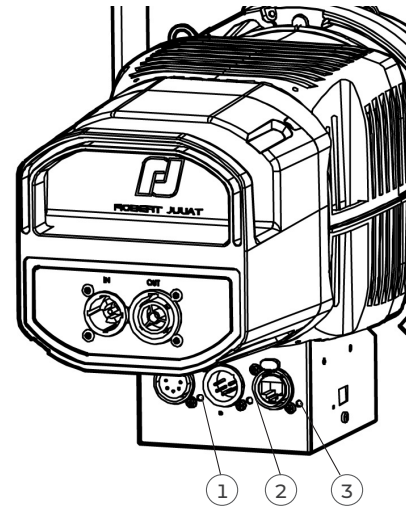

• After initialisation - Node mode "OFF":

1 DMX OUT	2 DMX IN	3 Network	Description
Ⓟ	Ⓟ	Ⓟ	Display auto-off
Ⓟ		Ⓡ	No ethernet
Ⓟ	Ⓢ	Ⓢ	Ethernet detected (link)
Ⓟ		Ⓟ	Ethernet detected + data
Ⓟ		Ⓡ	No ethernet
Ⓟ	Ⓟ	Ⓢ	Ethernet detected (link)
Ⓟ		Ⓟ	Ethernet detected + data
Ⓟ		Ⓡ	No ethernet
Ⓟ	Ⓡ	Ⓢ	Ethernet detected (link)
Ⓟ		Ⓟ	Ethernet detected + data
Ⓡ	Ⓡ	Ⓡ	Unit error

• After initialisation - Node mode "ON":

1 DMX OUT	2 DMX IN	3 Network	Description
Ⓟ	Ⓟ	Ⓟ	Display auto-off
	Ⓟ	Ⓡ	No ethernet
Ⓢ	Ⓟ	Ⓢ	Ethernet detected (link)
	Ⓟ	Ⓟ	Ethernet detected + data
	Ⓟ	Ⓡ	No ethernet
Ⓟ	Ⓢ	Ⓢ	Ethernet detected (link)
	Ⓟ	Ⓟ	Ethernet detected + data
Ⓡ	Ⓢ	Ⓢ	Ethernet detected (link)
	Ⓟ	Ⓟ	Ethernet detected + data
Ⓡ	Ⓡ	Ⓡ	Unit error

5.1.2 Parameters

5.1.2.1 Intensity

➔ Set through RDM protocol or web interface

Mode	Description
Display level	Adjust the intensity of the feedback LEDs

5.1.2.2 Auto-OFF

➔ Set through RDM protocol or web interface

Mode	Description
Always ON	Feedback LED, always ON
Timer without warning	Feedback LED OFF after 20 seconds
Timer with warning	Feedback LED OFF after 20 seconds, ON , if warning information occurs

5.2 DMX512 - A remote control

5.2.1 Protocol

E1.11 - 2008, USITT DMX512-A

5.2.2 Configuration

Set mode through web interface
(see 5.4.4 Web interface)

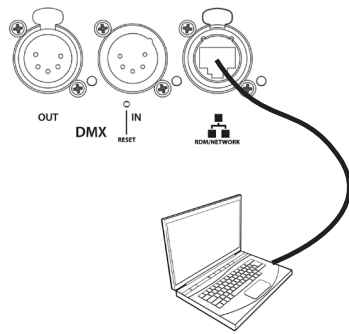

Set mode through RDM protocol

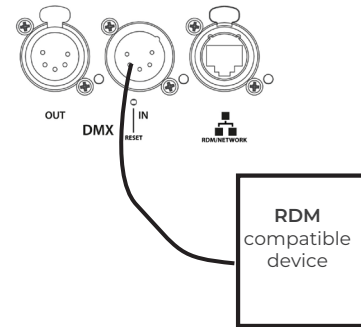

- 1 - Set DMX address
- 2 - Set personality mode (see 5.2.4. DMX chart)

5.2.3.1 DMX Hold

→ Selection in **SETUP / Data Setup / DMX HOLD** menu

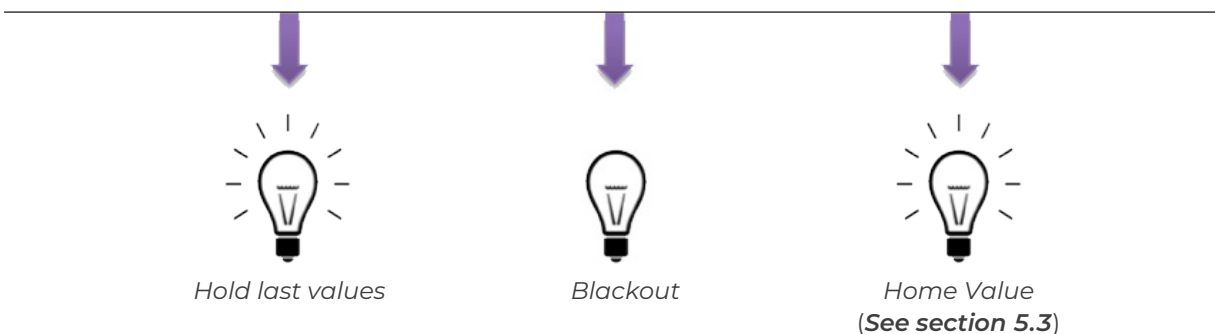

5.2.3.2 Fixture ID

→ Selection in **SETUP / DATA SETUP / FIXTURE ID** menu

Fixture ID can be set through web interface or RDM protocol or **local control**

Each unit can be identified by a Fixture ID number
 – Once defined, the Fixture ID is displayed on the Home screen.

Example: Installation with 6 units						
Home screen information	ID1 @ 101	ID2 @ 123	ID3 @ 145	ID4 @ 167	ID5 @ 189	ID6 @ 211
Fixture ID	1	2	3	4	5	6
DMX address	101	123	145	167	189	211

5.2.3.3 Terminator

Mode: Auto

A resistor of 120R is automatically connected to terminate the DMX line as the RS485 standard specifies.

5.2.3.4 Node

On sACN/ArtNet/Dual mode we have the possibility to transmit a DMX/RDM signal protocol on the DMX port (Output). The selection can be done through the menu/Webpage/RDM.

On Dual mode (sACN/ArtRdm) the node feature is automatically selected.

DMX Channel	Mode 1: Dimmer 8B	Mode 2: Profile 16B	Mode 3: Dimmer 8B CCT	Mode 4: Profile 16B CCT
1	Dimmer	Dimmer	Dimmer	Dimmer
2		Dimmer fine	Strobe duration	Dimmer fine
3			Strobe speed	Strobe duration
4			Response time	Strobe speed
5			Control mode	Response time
6				Control mode

5.2.5 DMX ranges

5.2.5.1 Strobe duration

Range min	Range max	Function
0	0	Strobe OFF
1	255	Strobe ON - 1 ms → 20 ms

5.2.5.2 Strobe speed

Range min	Range max	Function
0	255	Frequency: 0,1 Hz → 10 Hz

5.2.5.3 Response time

Range min	Range max	Function
0	0	OFF
1	255	Response time: 0,1 s → 4 s

5.2.5.4 Control mode*

Range min	Range max	Function
0	0	-
1	10	RDM OFF
11	20	RDM ON
21	30	Fixture Reset

(*) Function activated after 5 seconds - needs to go back to zero to activate second function.

5.2.6.1 Protocol

ANSI E1.20 – 2010 / ANSI E1.37 - 1

For more information about RDM protocol: <http://www.rdmprotocol.org/>

5.2.6.2 Functions

PID	Description	Standard	Get	Set	Queued_Message	Ack_Timer	VERSION 5.00
Network Management							
00 01	DISCOVERY_UNIQUE_BRANCH	E1.20					✓
00 02	DISCOVERY_MUTE	E1.20		✓			✓
00 03	DISCOVERY_UNMUTE	E1.20		✓			✓
00 15	COMMUNICATION_STATUS	E1.20	✓	✓			✓
Status Collection							
00 20	QUEUED_MESSAGE	E1.20	✓				✓
00 30	STATUS_MESSAGES	E1.20	✓				✓
00 31	STATUS_ID_DESCRIPTION	E1.20	✓				✓
00 32	CLEAR_STATUS_ID	E1.20		✓			✓
00 33	QUEUED_MESSAGE_SENSOR_SUBSCRIBE	E1.20-2023	✓	✓			
RDM Information							
00 50	SUPPORTED_PARAMETERS	E1.20	✓				✓
00 51	PARAMETER_DESCRIPTION	E1.20	✓				✓
Product Information							
00 60	DEVICE_INFO	E1.20	✓			✓	✓
00 70	PRODUCT_DETAIL_ID_LIST	E1.20	✓				✓
00 80	DEVICE_MODEL_DESCRIPTION	E1.20	✓				✓
00 81	MANUFACTURER_LABEL	E1.20	✓				✓
00 82	DEVICE_LABEL	E1.20	✓	✓	✓	✓	✓
00 90	FACTORY_DEFAULTS	E1.20	✓	✓		✓	✓
00 C0	SOFTWARE_VERSION_LABEL	E1.20	✓			✓	✓
00 C2	BOOT_SOFTWARE_VERSION_LABEL	E1.20	✓				✓
DMX512 Setup							
00 E0	DMX512_PERSONALITY	E1.20	✓	✓	✓	✓	✓
00 E1	DMX512_PERSONALITY_DESCRIPTION	E1.20	✓				✓
00 F0	DMX512_STARTING_ADDRESS	E1.20	✓	✓	✓	✓	✓
01 20	SLOT_INFO	E1.20	✓				✓
01 21	SLOT_DESCRIPTION	E1.20	✓				✓
Sensors							
02 00	SENSOR_DEFINITION	E1.20	✓				✓
02 01	SENSOR_VALUE	E1.20	✓				✓
Dimmer Settings							
03 40	DIMMER_INFO	E1.37-1	✓				✓
03 42	MAXIMUM_LEVEL	E1.37-1	✓	✓	✓	✓	✓
03 43	CURVE	E1.37-1	✓	✓	✓	✓	✓
03 44	CURVE_DESCRIPTION	E1.37-1	✓				✓
03 45	OUTPUT_RESPONSE_TIME	E1.37-1	✓	✓	✓	✓	✓
03 46	OUTPUT_RESPONSE_TIME_DESCRIPTION	E1.37-1	✓				✓
03 47	MODULATION_FREQUENCY	E1.37-1	✓	✓	✓	✓	✓
03 48	MODULATION_FREQUENCY_DESCRIPTION	E1.37-1	✓				✓
Power / Lamp Settings							
04 00	DEVICE_HOURS	E1.20	✓				✓
04 01	LAMP_HOURS	E1.20	✓	✓			✓
Display Settings							
05 01	DISPLAY_LEVEL	E1.20	✓	✓	✓	✓	✓

PID	Description	Standard	Get	Set	Queued_Message	Ack_Timer	SULLY
Control							
10	00	IDENTIFY_DEVICE	E1.20	✓	✓	✓	✓
10	01	RESET_DEVICE	E1.20		✓	✓	✓
10	20	PERFORM_SELFTEST	E1.20	✓	✓	✓	✓
10	21	SELF_TEST_DESCRIPTION	E1.20				✓
RDMnet Management							
07	00	LIST_INTERFACES	E1.37-2	✓			✓
07	01	INTERFACE_LABEL	E1.37-2	✓			✓
07	02	INTERFACE_HARDWARE_ADRESS_TYPE1	E1.37-2	✓			✓
07	03	IPV4_DHCP_MODE	E1.37-2	✓	✓	✓	✓
07	05	IPV4_CURRENT_ADDRESS	E1.37-2	✓		✓	✓
07	06	IPV4_STATIC_ADDRESS	E1.37-2	✓	✓		✓
07	09	INTERFACE_APPLY_CONFIGURATION	E1.37-2		✓		✓
07	0A	IPV4_DEFAULT_ROUTE	E1.37-2	✓	✓	✓	✓
07	0B	DNS_IPV4_NAME_SERVER	E1.37-2	✓	✓	✓	✓
PID Manufacturer							
85	58	SELFTEST_RESULT	E1.20	✓			✓
85	59	CURRENT_IP_ADDRESS	E1.20	✓		✓	✓
85	5A	CURRENT_NETMASK	E1.20	✓		✓	✓
85	5B	CURRENT_DRIVER_STATUS	E1.20	✓		✓	✓
85	5C	CUSTOM_RESPONSE_TIME_DESCRIPTION	E1.20	✓			✓
85	5D	CUSTOM_RESPONSE_TIME_VALUE	E1.20	✓	✓	✓	✓
85	60	DATA_MODE_DESCRIPTION	E1.20	✓			✓
85	61	DATA_MODE_VALUE	E1.20	✓	✓	✓	✓
85	62	STANDALONE_VALUE_DESCRIPTION	E1.20	✓			✓
85	63	STANDALONE_VALUE	E1.20	✓	✓	✓	✓
85	64	SACN_UNIVERSE_VALUE_DESCRIPTION	E1.20	✓			✓
85	65	SACN_UNIVERSE_VALUE	E1.20	✓	✓	✓	✓
85	66	ARTNET_UNIVERSE_VALUE_DESCRIPTION	E1.20	✓			✓
85	67	ARTNET_UNIVERSE_VALUE	E1.20	✓	✓	✓	✓
85	68	SERIAL_DESCRIPTION	E1.20	✓			✓
85	69	SERIAL	E1.20	✓	✓	✓	✓
85	6A	DMX_HOLD_DESCRIPTION	E1.20	✓			✓
85	6B	DMX_HOLD	E1.20	✓	✓	✓	✓
85	6C	COMMAND_LOCK_DESCRIPTION	E1.20	✓			✓
85	6D	COMMAND_LOCK_VALUE	E1.20	✓	✓	✓	✓
85	6E	DRIVER_CALIBRATE_DESCRIPTION	E1.20	✓			✓
85	6F	DRIVER_CALIBRATE_VALUE	E1.20	✓	✓	✓	✓
85	70	NODE_DESCRIPTION	E1.20	✓			✓
85	71	NODE_VALUE	E1.20	✓	✓	✓	✓
85	72	TERMINATOR_DESCRIPTION	E1.20	✓			✓
85	73	TERMINATOR	E1.20	✓	✓	✓	✓
85	74	DMX_ERROR_COUNTER_DESCRIPTION	E1.20	✓			✓
85	75	DMX_ERROR_COUNTER	E1.20	✓	✓	✓	✓

5.3 Home values & Standalone

“Home values” represent a selection of parameters manually entered into the device via the keypad to produce a defined lighting effect and dimming behavior.

These Home values can be set in the following modes:

Functions *	Mode 1: Dimmer 8B	Mode 2: Profile 16B	Mode 3: Dimmer 8B CCT	Mode 4: Profile 16B CCT	Standalone **
Dimmer	DMX	DMX	DMX	DMX	HOME VALUE
Response Time	HOME VALUE	HOME VALUE	DMX	DMX	HOME VALUE

If the function is not controlled by DMX, the Home value is automatically activated.

(*) Functions are displayed according to the selected mode (Mode 1-2-3-4).

- In the case of using one or more functions in Mode 1 / 2 / 3 / 4
Data mode → personality → Mode 1 / Mode 2 / Mode 3 / Mode 4

() Defines a standalone operating mode in the following cases:**

- As default values when used without data Data mode → Protocol → Standalone
- As reference values following a data signal loss. Set up → Data set up → DMX hold → Standalone

5.4 Network

Our network stack can handle several flows of protocol at the same time.

Protocol always available:

- Web page to set up parameters - *See section 5.4.4*
- LLRP (Low Level Recovery Protocol) for IP network configuration - *See section 5.4.5*

A selection of Protocols dedicated to lighting:

- Art-Net V4 - *See section 5.4.1*
- sACN - *See section 5.4.2*
- Dual: Sacn + Art-RDM (DMX512 data signal + RDM) - *See section 5.4.3*

From July 2024 the Robert Juliat equipment based on RJ LED2 platform is configured as follows:

- DHCP (**D**ynamic **H**ost **C**onfiguration **P**rotocol - **RFC1531**) ON
→ <https://www.rfc-editor.org/rfc/rfc1531>
- Zeroconf (**Z**ero-**C**onfiguration **N**etworking – **IPv4LL/APIPA – RFC3927**) ON
→ <https://www.rfc-editor.org/rfc/rfc3927>

IP Addressing of Parameters - *See section 5.1.2*

Default:

- At startup, the device's IP address is set to 000.000.000.000 with a subnet mask of 000.000.000.000
- After connecting to the network, the device awaits the assignment of an IP address and subnet mask by the DHCP server.
- If there is no DHCP server, a unique IP address and subnet mask are automatically assigned.
IP : 169.254.XXX.XXX Mask : 255.255.0.0

Most personal computers are configured with DHCP and Zeroconf enabled, so the IP address defaults to 169.254.X.X with a subnet mask of 255.255.0.0.

When connected to a Robert Juliat device, since the IP address/mask range are in the same class, network communication works seamlessly.

This configuration was chosen to make it easier for non-IT technicians.

Static IP:

It's possible to configure a static IP address, but be sure to select a unique IP address with the correct subnet mask.

Configuration can be done via the Web Page, RDM, LLRP, Art-Net, or locally.

Default IP Address:

When DHCP mode is OFF and no static IP address has been selected, the device will default to a Class A IP address of 2.XXX.XXX.XXX with a subnet mask of 255.0.0.0.

This address can be found on a label near the ID plate or by pressing the right arrow on the local control.



Changing the Controlling Computer's IP Address:

- The IP address and subnet mask of both the fixture and the computer must be on the same network class.
- The computer's IP address must be different.
- Refer to your operating system's support to modify IPv4 settings:

Change your IP address on Windows

➔ <https://support.microsoft.com/en-us/windows/change-tcp-ip-settings-bd0a07af-15f5-cd6a-363f-ca2b6f391ace>

Change your IP address on Mac

➔ <https://support.apple.com/en-ae/guide/mac-help/mh14129/mac>

Example: Using the fixture's default IP address

1 - Computer IP address: 2.2.2.2

2 - Computer subnet mask: 255.0.0.0

5.4.1.1 Protocol

Artistic Licence Art-Net v4.

For more information about Art-Net protocol: <http://art-net.org.uk/>

5.4.1.2 Configuration

Set mode through Web interface
(see 5.4.4 Web interface)

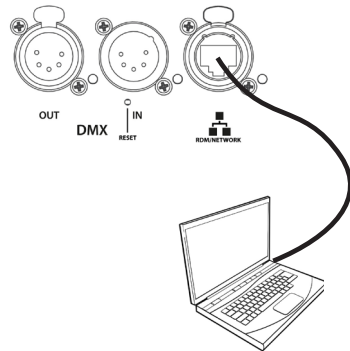

Set mode through RDM
protocol

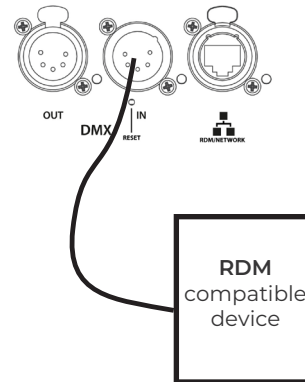

- 1 - If necessary, change IP settings
- 2 - Set Art-Net Universe
- 3 - Set DMX address
- 4 - Set personality mode (see 5.2.4. DMX chart)

5.4.2.1 Protocol

ANSI E1.31 – 2009 sACN (Streaming-ACN)

5.4.2.2 Configuration

Set mode through Web interface
(see 5.4.4 Web interface)

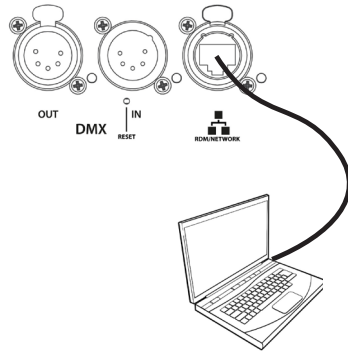

Set mode through RDM
protocol

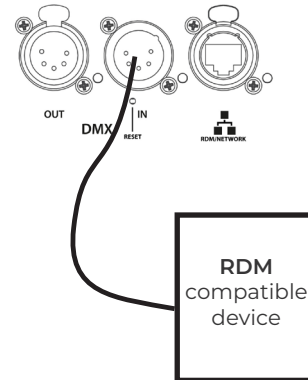

- 1 - If necessary, change IP settings
- 2 - Set sACN universe
- 3 - Set DMX address
- 4 - Set personality mode (see 5.2.4. DMX chart)

5.4.3.1 Protocol

Dual Mode: Available only on an Ethernet network

It allows to send a DMX 512 signal through a sACN data stream and at the same time to use an Artnet/ArtRdm data stream to control, set and monitor the equipment via RDM.

This mode can be set by Web interface or the local control screen.

5.4.3.2 Configuration

Set mode through Web interface
(see 5.4.4 Web interface)

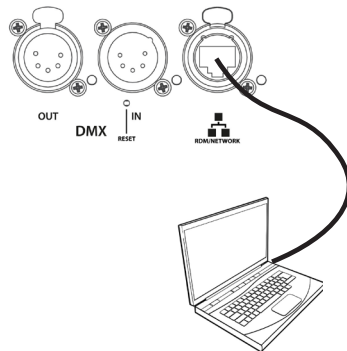

Set mode through RDM
protocol

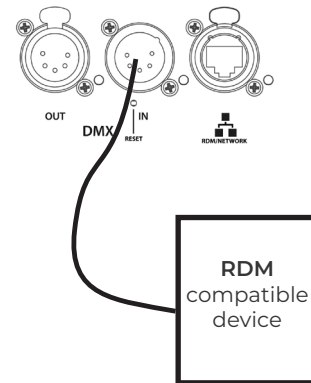

- 1 - If necessary, change IP settings
- 2 - Set DUAL universe
- 3 - Set DMX address
- 4 - Set personality mode (see 5.2.4. DMX chart)

5.4.4.1 Control

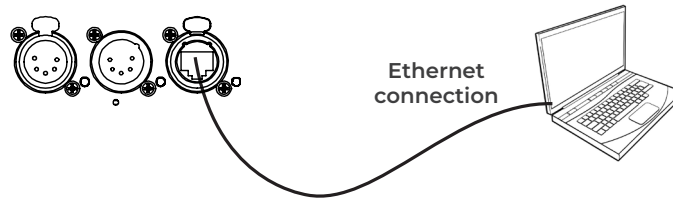

The fixture must be connected to a compatible network or directly linked to a computer with an RJ45 Ethernet cable.

The fixture's IP address: see section 5.4. Network

5.4.4.2 Connection to the Web interface

- 1 - Open a web browser (Microsoft Edge, Firefox, Apple Safari...)
- 2 - Enter the fixture's IP address in the browser's address bar



- "00X" is read as "X".
- Never type a zero (0) before the numbers XX or X (see 5.4)

- 3 - The HOME page will appear, and all settings can now be viewed and modified.

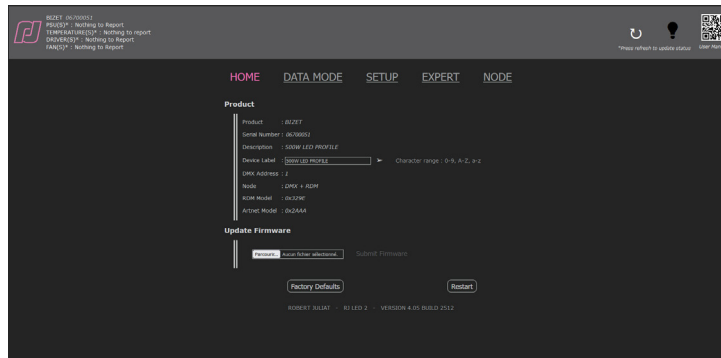

HOME Page

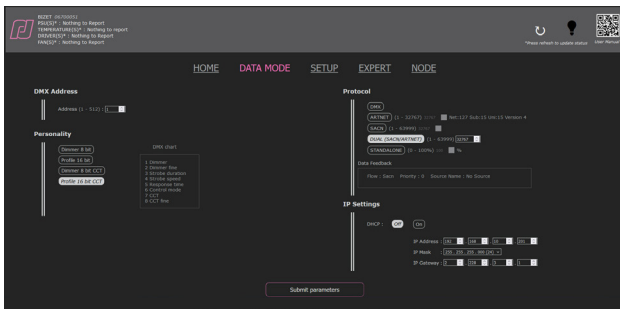

DATA MODE Page



SETUP Page

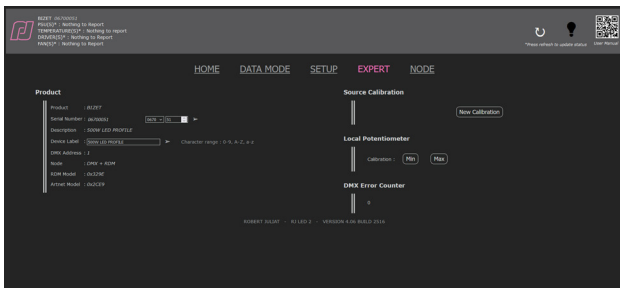

EXPERT Page, password-protected (1280).

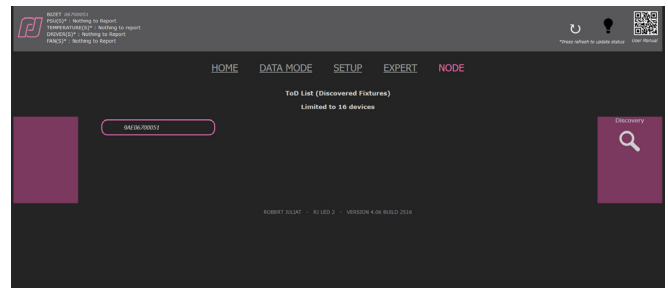

NODE Page

UID* list of devices detected by RDM on the DMX OUT link; the first UID is the fixture.

(*) UID : RDM Unique Identifier

5.4.5 LLRP (Low-Level Reader Protocol)

LLRP is a multicast protocol that facilitates basic IP configuration. It is part of the ESTA E1.33 RDMnet standard.

LLRP can be used for the initial configuration of networked equipment. It provides a low-level mechanism for discovering and configuring the network parameters of devices, including IP settings and basic RDMnet configuration settings.

LLRP Targets expose these parameters for configuration and respond to discovery requests from LLRP Managers. Once an LLRP Manager discovers one or more LLRP Targets, it can use LLRP to send RDM commands to retrieve or modify these parameters.

A SOLUTION FOR INCORRECT OR UNKNOWN IP CONFIGURATION

Network connectivity issues are often caused by misconfigured network addresses, with improperly configured subnet masks being the most common problem.

LLRP uses two multicast IP addresses, enabling communication even when all other network communication has failed.

Since multicast addresses are unaffected by a misconfigured subnet mask, LLRP provides an efficient and reliable solution to recover from network misconfiguration.

In summary, LLRP simplifies the process of identifying and configuring the IP addressing of LLRP-compatible devices on your network.

All Robert Juliat equipment based on the RJ LED2 platform includes LLRP functionality.

Two LLRP Manager software tools are available for free:

- DMXworkshop by Wayne Howell from Singularity (UK): <https://singularity-uk.com/product/dmx-workshop/>

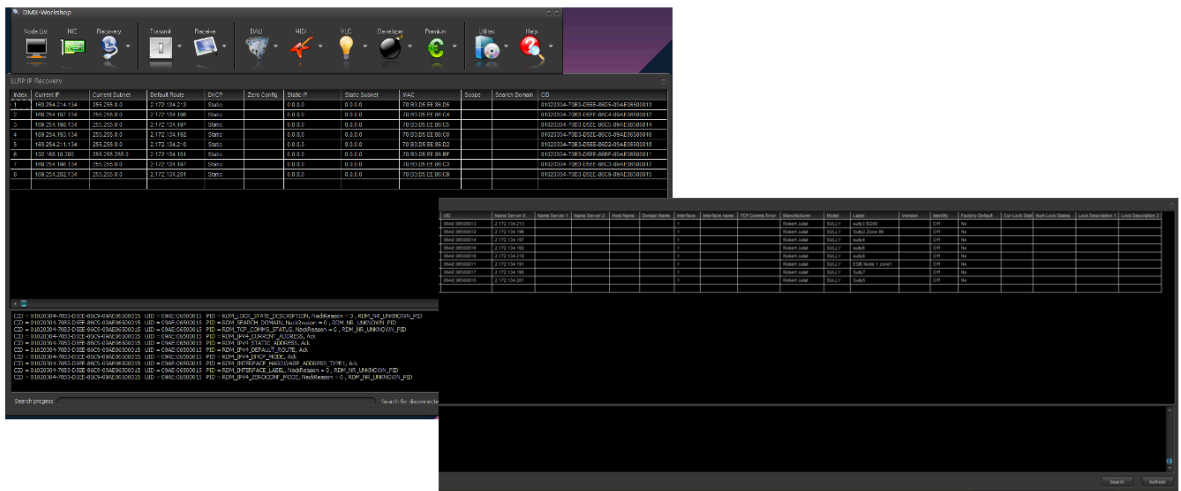

- CLU/Netron from Obsidian : <https://obsidiancontrol.com/netron-clu>

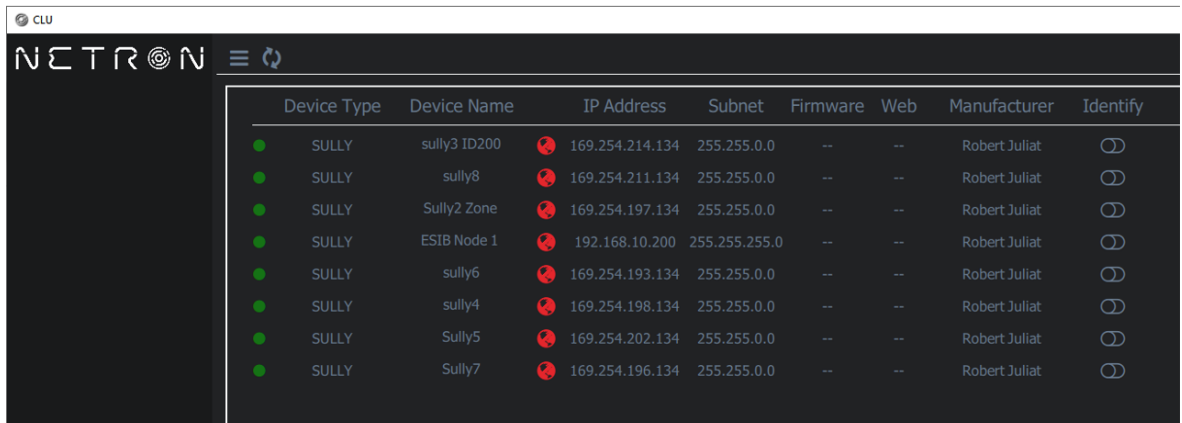

6.1 Preventive maintenance

6.1.1 Frequency

General maintenance should be performed at least once a year or more frequently if the equipment is operated in adverse conditions (smoke, heat, humidity, touring, etc.).

6.1.2 General cleaning

Remove dust from the unit.

6.1.3 General visual check

- No trace of heat.
- No loose contacts.
- No missing parts.
- Tighten mechanical assemblies (screws, bolts and nuts, etc.).

6.1.4 LED source



- Do not touch the surface of the LED source (no contact with your hands or any tools).
- Do not put compressed air directly on the source.
- Contact a certified RJ distributor in case of residuals or other objects located on the surface of the LED source.

6.1.5 Optics

Only use solutions containing alcohol to clean optical parts (lenses).

- To clean the optical parts, use a soft cloth in combination with distilled water or isopropyl alcohol recommended for coated optics. Do not use any cleaning product that contains solvents or abrasives, as these can cause surface damage.
- Dry with a soft lint-free cloth.

Step by Step access to clean the zoom lenses:

- 1 - Remove the top cover with the 1/4 turn fastener (a).
- 2 - Remove the extra lens if mounted (b).
- 3 - Slide the lever (step 1) towards the front of the fixture and turn the rear lens 90° (step 2), to have access to the front side of the biconvex lens (c).

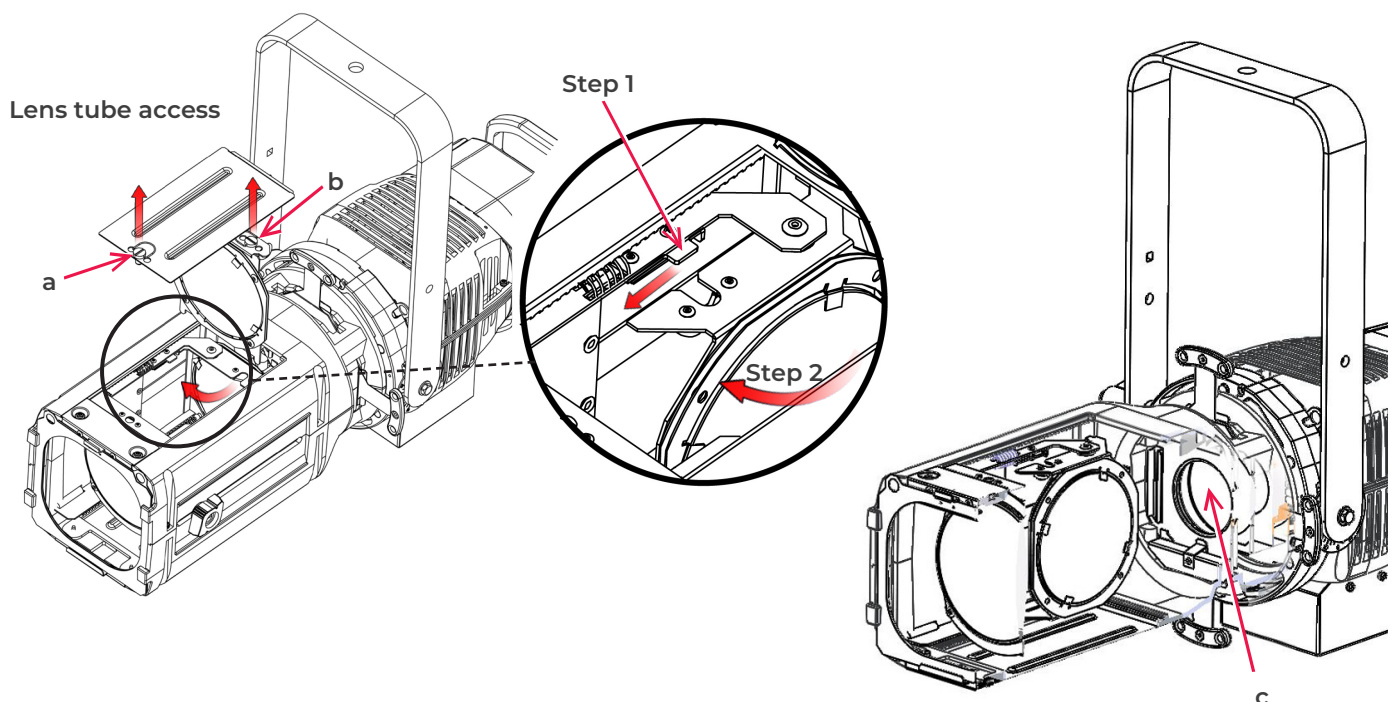

6.2 Analysis

In case of problem, contact RJ distributor with the following information:

- Model, version and serial number of the product.
- From the menu status:
 - Software version
 - LED board IDs
 - Device hours
- Description of the problem.



6.3 Electronic thermal management system

In case of overheating, light intensity will be reduced by the system.

"Power reduction X%" will be shown on the display with the reducing percentage.

6.4 Firmware update





After updating your device with firmware V3.0, we strongly recommend that you update the source type (CCT) either to CW (Cold White) or WW (Warm White) by following the procedure described in the section below: **CCT selection**

CCT selection

Until now, the CCT of the LED source was not taken into account. From V3.0, your device will be automatically recognized as CW or WW source.

Devices shipped with firmware prior to V3.0 do not have a designated CCT. After updating to V3.0, it is highly recommended to specify the CCT of your device. For this you will have to stay on the Web Page that you used for the update.

In the **Source** section of the HOME tab, the CCT of your device is indicated.

- If "unknown", please select the CCT of your device and click on icon  or , then on the arrow .

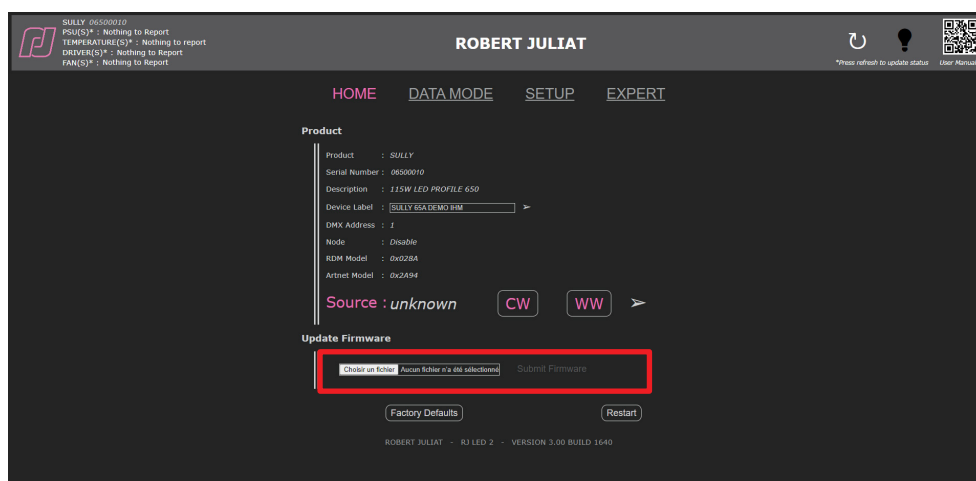

- Changing the source type changes the Model_ID as well. It is used in libraries to recognize devices automatically and for an Auto-Patch.
- If the source type has to be changed or in case of typing error, it will be always possible to change the source type in the Expert mode which is protected by a password.

1. Download the firmware from one of the following links :
 - www.robertjuliat.com/LED/PDF_PAGE or scan the QR code:
 - www.robertjuliat.com/profilespots/TIBO-HE_553_115W-LED
2. Unzip the file. There are 4 files:
 - Firmware (.upd2 format)
 - Firmware history
 - Update procedure
 - User manual from firmware version V5.0x onwards
3. Switch on the lighting fixture.
4. Connect the fixture to the network using an RJ45 Ethernet cable from your computer.

You can either connect it to your lighting network (RJ45) or directly to your computer (RJ45).
5. Open a Web browser (Microsoft Edge, Firefox, Apple Safari, etc.).
6. Enter the fixture's IP address in the browser's address bar
 - "00X" is read as "X".
-  · Never type a zero (0) before the numbers XX or X (see section 5.4).
7. Upload your firmware file (.upd2).

In the "Update firmware" window, select the update file and then click on "Submit firmware".

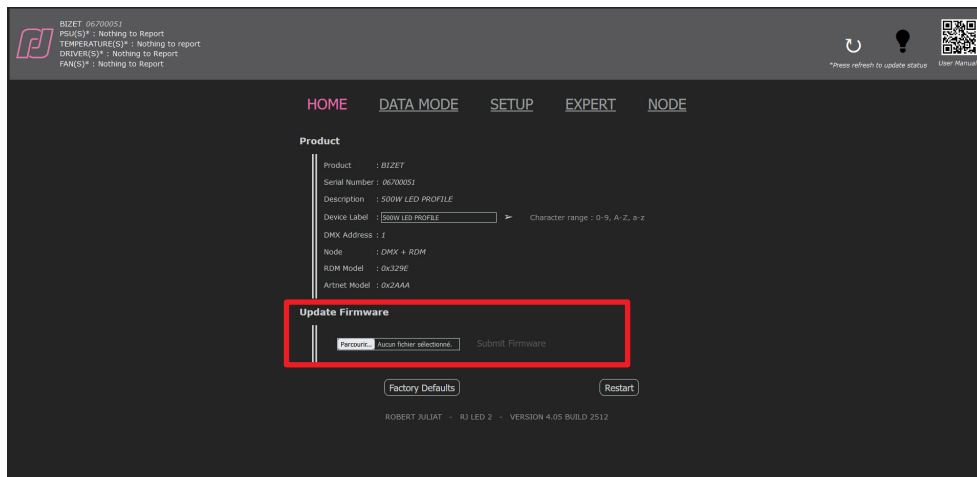

6.5 Factory defaults

6.5.1 Modes

Mode	Description
Restart	Software reset – all user parameters are kept
Factory defaults	Set all user parameters to factory default value

6.5.2 Control

Set to factory defaults /
reset through web interface
(Home page)

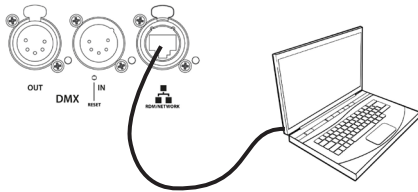

Set to factory defaults /
reset through RDM protocol

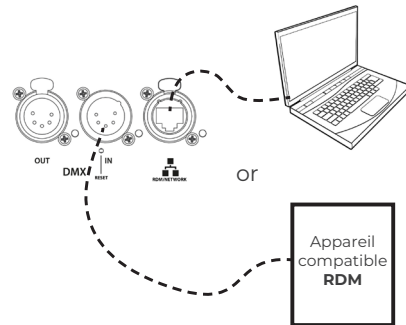

➔ If IP address unknown (due to a previous modification), IP address can be read from RDM protocol or a **hard reset** must be done:

	<p>While holding down the reset button with a paper clip, connect the unit to power and continue to hold the reset button until the 3 status light turn green. The system is then ready for setup.</p>
--	--

6.6 Testing for errors

Testing and errors can be detected through RDM.

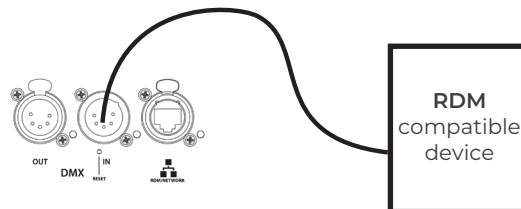

Test Report

Any FAILURE or ERRORS must be noted for feedback.

If the problem persists, please take a photo of the test result and send it either to your Robert Juliat dealer or to the Robert Juliat After-Sales Service, if requested (email: service@robertjuliat.fr)