

SULLY 1156

Manual

115W LED FOLLOWSPOT

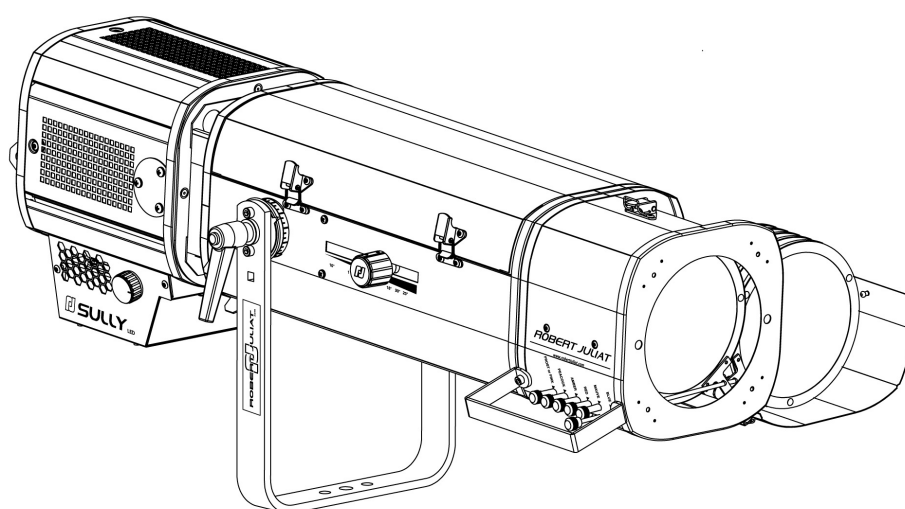

Model	Standard	North American
10.5° – 22.5° Warm White (WW)	1156WW	1156CWW
10.5° – 22.5° Cool White (CW)	1156CW	1156CCW

Product
Updates:



V1

- FIRMWARE: V5.0x
- RJ-LED2 FIRMWARE PLATFORM (Node Mode) full manual is
available for download at www.robertjuliat.com/LED/PDF_PAGE

DN41202001-A (EN)

Released: 01/06/26



ROBERT JULIAT

Table of Contents

1	User's instructions	1	5	Controls and parameters	20
2	Presentation	2	5.1	Local display and controls	20
2.1	Functions	2	5.1.1	Display	20
2.2	Identification labels	2	5.1.2	Home screen	20
2.2.1	Label on LED compartment	2	5.1.3	Menus	21
2.2.2	Label on lighting unit	3	5.1.4	Parameters	22
2.3	Accessories included	3	5.2	DMX512 - A remote control	23
2.4	Accessories	4	5.2.1	Protocol	23
3	Set-up	5	5.2.2	Configuration	23
3.1	Mechanics	5	5.2.3	Parameters	24
3.1.1	Operating positions	5	5.2.3.1	DMX Hold	24
3.1.2	Minimum distance between a flammable material	5	5.2.3.2	Fixture ID	24
3.1.3	Instructions for use	5	5.2.3.3	Terminator	24
3.1.4	Lifting	5	5.2.3.4	Node	24
3.1.5	Stand set-up	6	5.2.4	DMX chart	25
3.2	Electrical information	6	5.2.5	DMX ranges	25
3.2.1	LED source	6	5.2.5.1	Strobe duration	25
3.2.2	Power supply	6	5.2.5.2	Strobe speed	25
3.3	DATA	7	5.2.5.3	Response time	25
3.3.1	DMX 512-A / RDM	7	5.2.5.4	Control mode	26
3.3.2	Art-Net / sACN / DUAL	8	5.2.6	RDM remote control	27
3.3.3	Ethernet / DMX node / DUAL	8	5.2.6.1	Protocol	27
3.4	Accessories	9	5.2.6.2	Functions	27
3.4.1	Iris	9	5.3	Home values & Standalone	29
3.4.2	Gobo holder	9	5.4	Network	29
3.4.3	Internal filter holder	10	5.4.1	Art-Net remote control	31
3.4.4	Colour changer unit - push-pull	10	5.4.1.1	Protocol	31
3.4.5	Double slot front cassette for front accessories (option)	11	5.4.1.2	Configuration	31
3.4.6	Double-condenser set	12	5.4.1.3	Local set-up	32
4	Operations	13	5.4.2	sACN remote control	33
4.1	Light intensity	13	5.4.2.1	Protocol	33
4.1.1	Range	13	5.4.2.2	Configuration	33
4.1.2	Control	13	5.4.2.3	Local set-up	34
4.1.3	Parameters	13	5.4.3	Dual remote control	35
4.1.3.1	Dimming resolution - DMX only	13	5.4.3.1	Protocol	35
4.1.3.2	Dimming curve	14	5.4.3.2	Configuration	35
4.1.3.3	Master control	14	5.4.3.3	Local set-up	36
4.1.3.3	Set maximum position	14	5.4.4	Web interface	37
4.1.3.4	Dimming mode	15	5.4.4.1	Control	37
4.2	Strobe	15	5.4.4.2	Connection to the Web interface	37
4.2.1	Range	15	5.5	LEDs Feedback	38
4.2.2	Control	15	5.5.1	Trouble shooting	38
4.3	Response time	15	5.5.2	Parameters	38
4.3.1	Range	15	5.5.2.1	Intensity	38
4.3.2	Control	16	5.5.2.2	Auto-OFF	38
4.4	Beam size adjustment	16	6	Service	39
4.4.1	Range	16	6.1	Preventive maintenance	39
4.4.2	Control	17	6.1.1	Frequency	39
4.5	Orientation	17	6.1.2	General cleaning	39
4.5.1	Range	17	6.1.3	General visual check	39
4.5.2	Control	17	6.1.4	LED source	39
4.6	Iris	18	6.1.5	Optics	39
4.6.1	Range	18	6.1.6	LED house cleaning	39
4.6.2	Control	18	6.1.7	LED module cleaning procedure	40
4.7	Gobo	18	6.2	Analysis	40
4.7.1	Range	18	6.3	Electronic thermal management system	41
4.8	Colour	18	6.4	Firmware update	41
4.8.1	Range	18	6.5	Factory defaults	42
			6.5.1	Modes	42
			6.5.2	Control	42
			6.6	Selftest	42
			6.7	Testing for errors (LED unit without a display screen)	43

1 User's instructions

GENERAL INSTRUCTIONS

1. Not for residential use.
2. These fixtures must only be serviced by a qualified technician.
3. In addition to the instructions indicated on this page, relevant health and safety requirements of the appropriate EU Directives must be adhered to at all times.
4. This fixture is in compliance with section 17 - Lighting appliance for theatre stages, television, cinema and photograph studios.
Standards NF EN 60598-1, NF EN 60598-2-17, Low Voltage Directive 2014/35/UE & EMC Directive 2014/30/UE.
5. This fixture is rated as IP20, and is for indoor use only.

FIXTURE

6. Ensure fixture is correctly mounted on an appropriate support.
7. Protection screens and lenses must be replaced in the event of any damage, such as cracks or deep scratches, since these might reduce performance.
8. When hung or flown the fixture must be secured by an additional hanging accessory (such as a safety cable or bond) of suitable length.
9. Safety bonds or cables must be securely attached to the back of the fixture and be as short as possible, or rolled up as necessary, to minimise travel distance should the fixture be dislodged.
10. Movable accessories (scroller, etc.) must also be secured with a suitable safety cable or bond at the front of the fixture.
11. The combined weight of both the fixture and the accessories must be considered when choosing the load-bearing capability of safety cable or bond.
12. Do not open lighting fixture when the source is on.
13. WARNING: LED source becomes hot during use. Allow fixture to cool before servicing.
14. Do not tamper with design of fixture nor any of its safety features.
15. Tighten electrical mains cable connections regularly and replace with one of identical specification if damaged.
16. Use only with correct power supply.

VENTILATION

17. Keep well away from flammable material.
18. Not for outdoor use. Do not cover. Do not permit fixture to get wet.
19. To avoid overheating, do not obstruct air vents.
20. Ensure any cooling fans are in correct working order. If fans are not working, turn fixture off immediately and service as necessary.

CLEANING

21. Do not touch the LED source with your fingers.
22. To clean the optical parts, use a soft cloth in combination with distilled water or isopropyl alcohol recommended for coated optics. Do not use any cleaning product that contains solvents or abrasives, as these can cause surface damage.
Dry with a soft lint-free cloth.
23. Regularly remove dust with a soft lint-free cloth.
24. If the fixture has filters, they must be cleaned frequently.

POWER SUPPLY

25. Disconnect from the mains before servicing.
26. Mains connection only. Do not connect to "electronic output" such as dimmer.
27. Ensure power supply circuit breakers, always remain accessible.

PLEASE NOTE

This product has been built to conform to European standards relating to professional lighting equipment. Any modification made to our products will void the manufacturers' warranty.

Photobiological safety according to EN62471

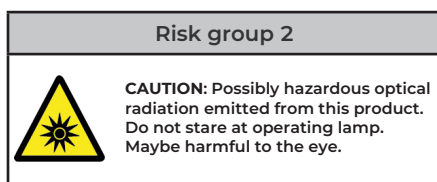
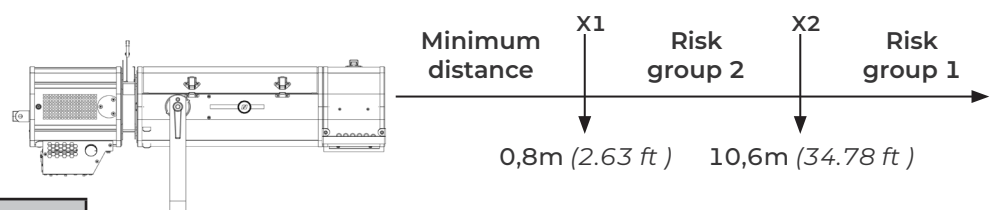

Group risk 2. Luminaires should be positioned so that prolonged staring into luminaire at a distance closer than 10,6m is not expected.

2 Presentation

2.1 Functions

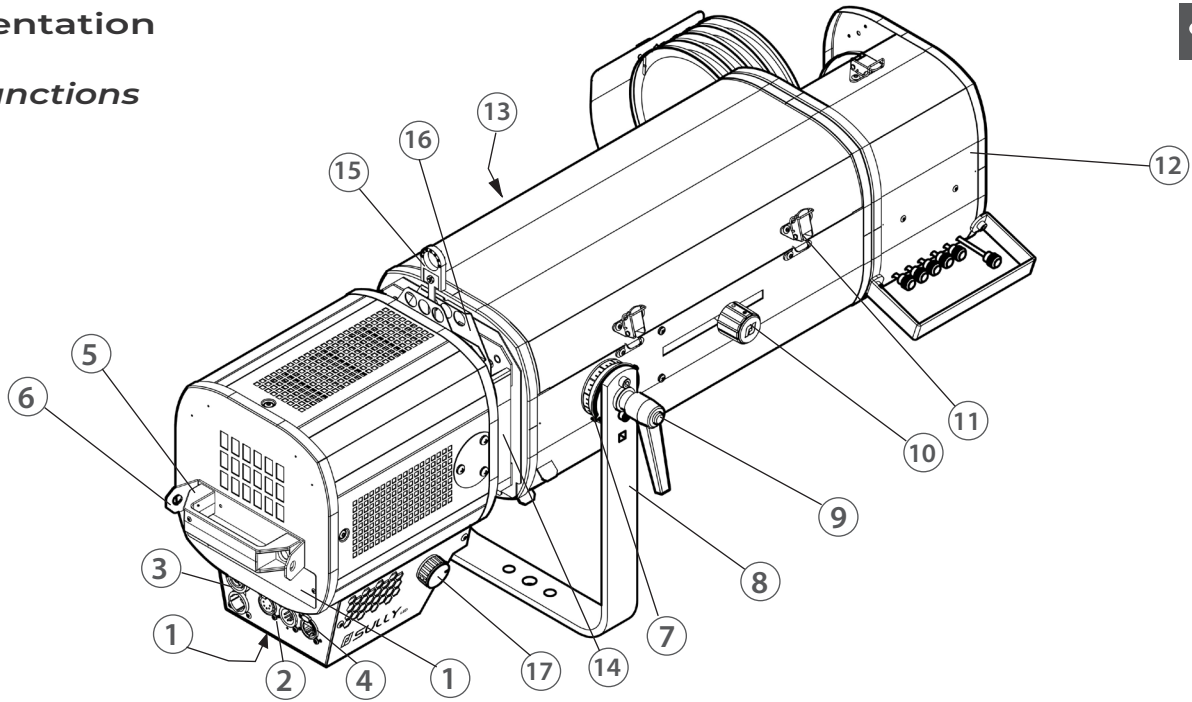

Description	
1. Identification plates	11. Lens tube access
2. Data connector (IN and OUT)	12. Colour changer
3. Power connector (IN and OUT)	13. Zoom adjustment
4. RJ45 network connector	14. Gate: slots for gobo holder and/or iris
5. Handle	15. Iris
6. Safety cable attachment point	16. Gobo holder
7. Tilt index	17. Dimmer
8. Yoke	
9. Locking handle	
10. Focus adjustment	

2.2 Identification labels

2.2.1 label on LED compartment

Description	
<p>19 17 18 15 16 20</p> <p>LED FIXTURE Risk Group </p> <p>Lire le manuel avant utilisation - Utilisation et maintenance par professionnel uniquement / Read manual before use - Service only by qualified personnel.</p> <p>MOD. 1 VERS. 2 11 9</p> <p>U 3 I 4 10</p> <p>P 5 IP 6 13 14</p> <p>t°a 7 t°c 8 </p> <p>ROBERT JULIAT.com 12 </p> <p>Made in the EU - France -</p>	<ol style="list-style-type: none"> MOD.: Model VERS.: Version U : Nominal voltage input (V) I : Nominal intensity (A) P : Maximum power input (W) IP : International Protection Rating t°a : Maximum ambient temperature (°C) t°c : Maximum external temperature of the unit (°C) Net weight (kg) Minimum distance between a flammable material and the lighting unit (m) Colour temperature version Serial number Replace broken glass Class 1 product label Read manual first label European conformity label WEEE directive label CEI-TR-62778 - Do not stare at light source EN62471 - Risk group UKCA (UK Conformity Assessed) label
<p>Units:</p> <ul style="list-style-type: none"> - Weight = kilogram (kg). - Intensity = Ampere (A). - Voltage = Volt (V). - Frequency = Hertz (Hz). - Temperature = degree Celsius (°C). 	

Description

**GOBO
"A" SIZE
TAILLE "A"**

DE41202601

*Disconnect from mains supply before servicing. Both source and housing become hot during use, allow fixture to cool before servicing. Keep well away from flammable material. Do not cover. This fixture is rated as IP20, and is for indoor use only. **This fixture must only be serviced by a qualified technician.***

*Isoler électriquement avant toute intervention. Source et corps chauds, attendre que l'appareil soit froid avant toute intervention. Ne pas placer le projecteur à proximité de matière inflammable. Ne pas couvrir. Cet appareil est considéré IP20 et réservé à une utilisation intérieure. **Intervention par technicien qualifié uniquement.***

4

1

2

8

7

3

5

6

9

1. Model beam angles
2. Net weight (kg) without LED compartment
3. Serial number
4. Class 1 product label
5. Read manual first label
6. European conformity label
7. WEEE directive label
8. Operating positions
9. UKCA (UK Conformity Assessed) label

Units:

- Weight = kilogram (kg).
- Intensity = Ampere (A).
- Voltage = Volt (V).
- Frequency = Hertz (Hz).
- Temperature = degree Celsius (°C).

2.3 Accessories included

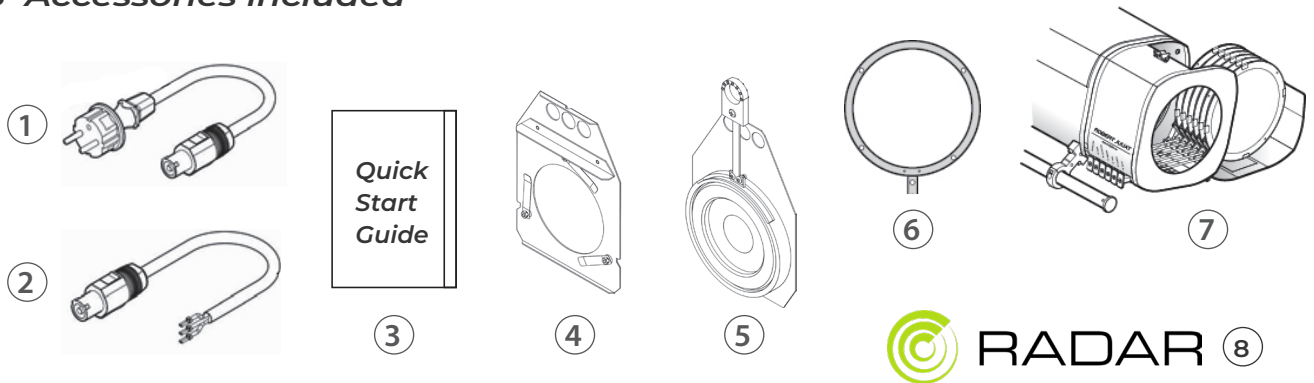

	Reference	Description
1	CAL03	Power cable with CEE 7/7 type in connectors (standard version)
2	CAL04	UL/CSA power cable without connector (North-American version)
3	DN41202400	Quick Start manual
4	SGUX	Universal "A" size gobo holder (metal, glass or frosted glass)
5	IS750	Full closing iris with holder
6	PF1114	Ø165 mm metal filter holder (x6)
7	M165TP	6-way "push/pull" colour changer
8	Fusion/RJ	Madrix Radar (RDM monitoring): Fusion RJ licence - access to all RDM parameters of RJ fixtures

MADRIX RADAR - more information: www.robertjuliat.com/RDM-Tools/Madrix_Radar

2.4 Accessories

EN

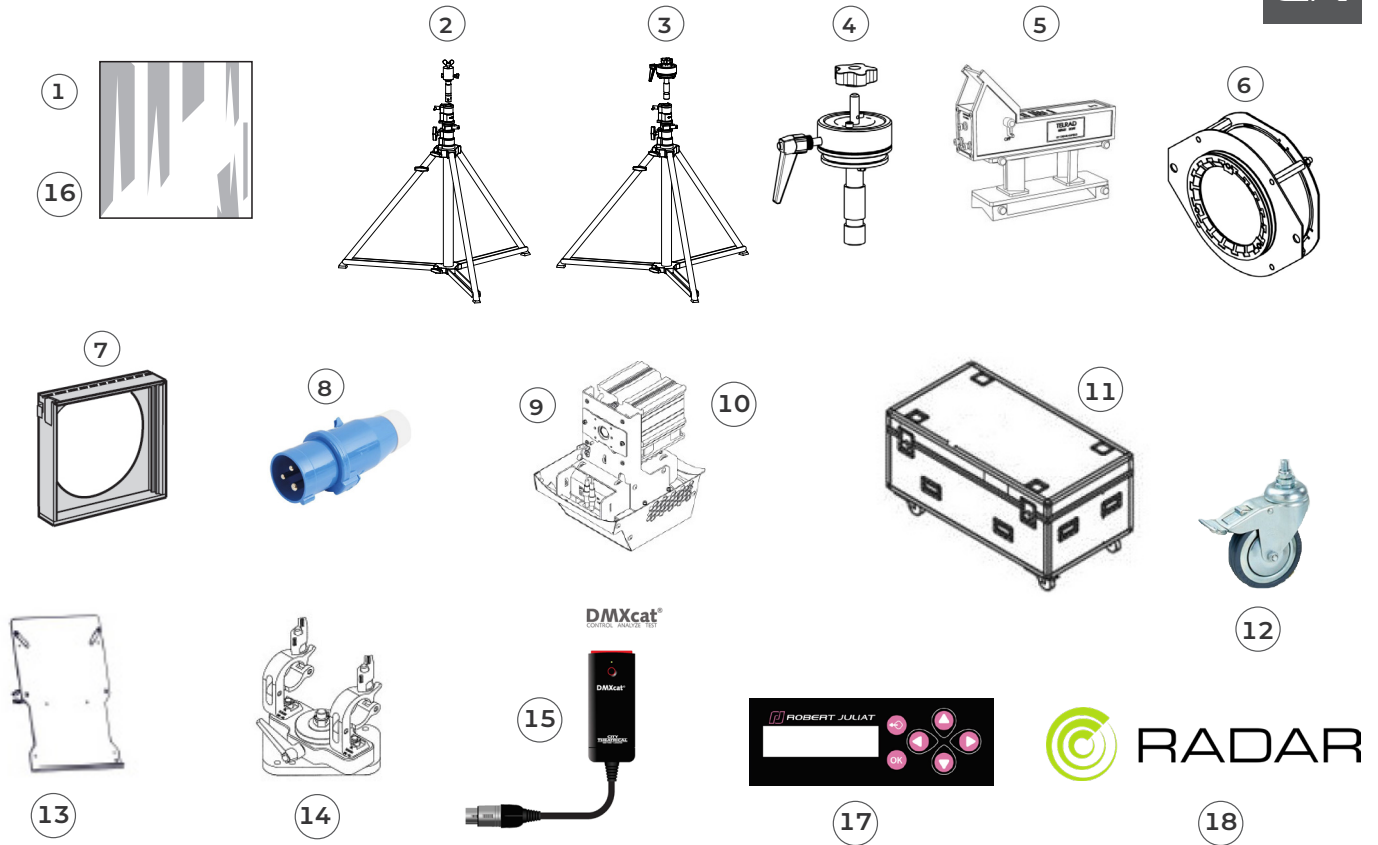

	Reference	Description
1	VD120	120 x 120 mm frosted glass
2	GT800	Tripod stand GT800 - SWL: 40 kg max. height 1550 mm
3	GT1000	Tripod stand GT1000 - SWL: 40 kg max. height 1550 mm
4	T1000	TV spigot with followspots swivel head
5	Kit TELRAD	Followspot sight with riser
6	APH 68LED	Double-condenser set for Led profile
7	CAV600A	Double slot front cassette for 180x180mm accessories
8	PCP1716A	16A blue 2P+E 6h IEC60309 power connector
9	T/1650SXCW	SULLY 115W LED compartment with potentiometer - Cool White - 3 meter power cable with CEE 7/7 (2P+T NF/SCHUKO) connector
10	T/1650SXWW	SULLY 115W LED compartment with potentiometer - Warm White - 3 meter power cable with CEE 7/7 (2P+T NF/SCHUKO) connector
11	FC1124/S	Transport flight-case for ultra compact range followspots
12	W/GT800	Set of 3 wheels for GT800/1000 stands
13	SDUP	Followspot cue sheet holder with universal mounting kit
14	T4000	Followspot mount for Ø50 mm pipe (suspension or overhead) - SWL= 100 Kg
15	DMXcat	Bluetooth DMX/RDM Multifunction test tool - City Theatrical DMXcat®
16	FO120C-1	120x120mm 1° frost optical filter
	FO120C-10	120x120mm 10° frost optical filter
	FO120C-2	120x120mm 2° frost optical filter
	FO120C-5	120x120mm 5° frost optical filter
17	DISP2	Display and keyboard for local setup
18	Fusion/S	Madrix Radar (RDM monitoring): Fusion Small licence - up to 64 non-RJ RDM fixtures - USB dongle included
	Fusion/M	Madrix Radar (RDM monitoring): Fusion Medium licence - up to 512 non-RJ RDM fixtures - USB dongle included
	Fusion/L	Madrix Radar (RDM monitoring): Fusion Large licence - up to 4096 non-RJ RDM fixtures - USB dongle included

MADRIX RADAR – more information: www.robortjuliat.com/RDM-Tools/Madrix_Radar

3 Set-up

3.1 Mechanics

3.1.1 Operating positions

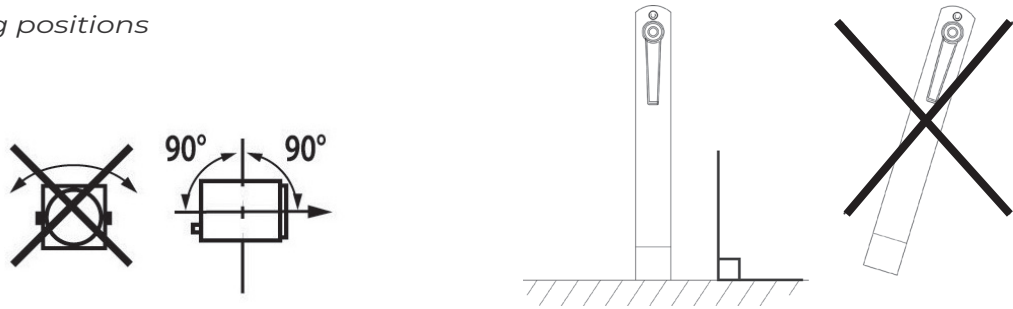

3.1.2 Minimum distance between a flammable material and the lighting unit

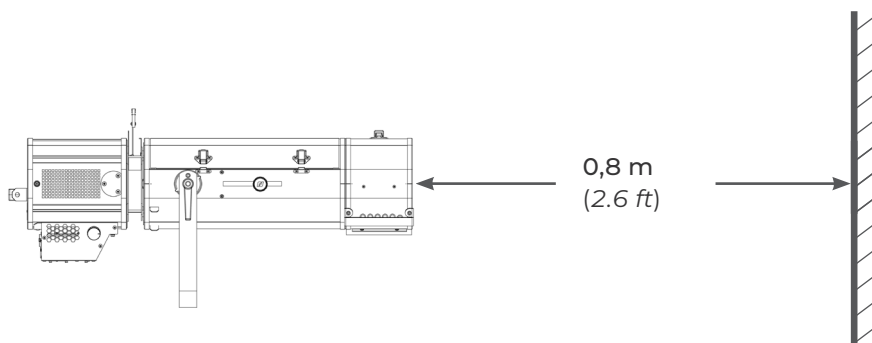

3.1.3 Instructions for use

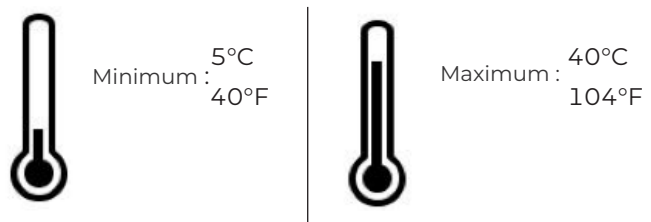

3.1.4 Lifting

IP20 - Indoor use only

• Net weight: 15.6 Kg (34,3 lbs).

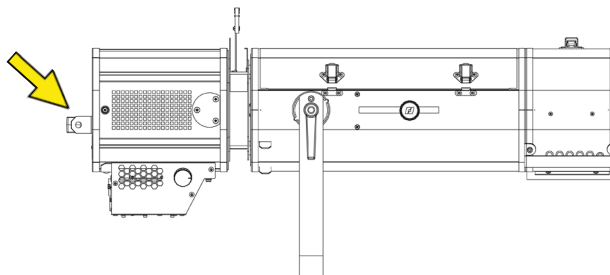

3.1.5 Stand set-up

- Compatible stands : GT800 & GT1000

Please refer to the relevant user manual for further details.

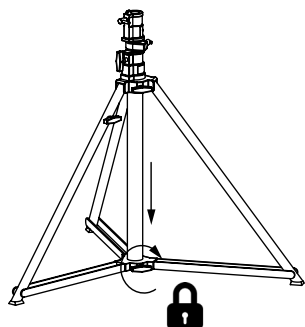

↓ MAX
40kgs/88lbs

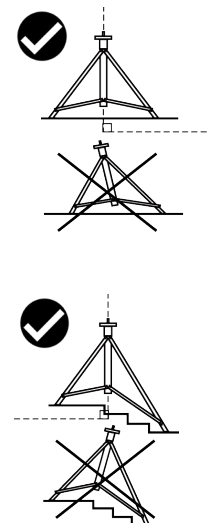
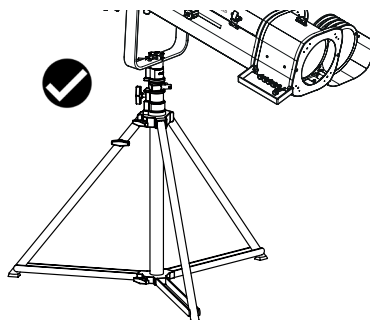

3.2 Electrical information

3.2.1 LED source



Never touch or scratch the LED surface.

See 6.1.4 LED cleaning procedure if cleaning is necessary.

3.2.2 Power supply

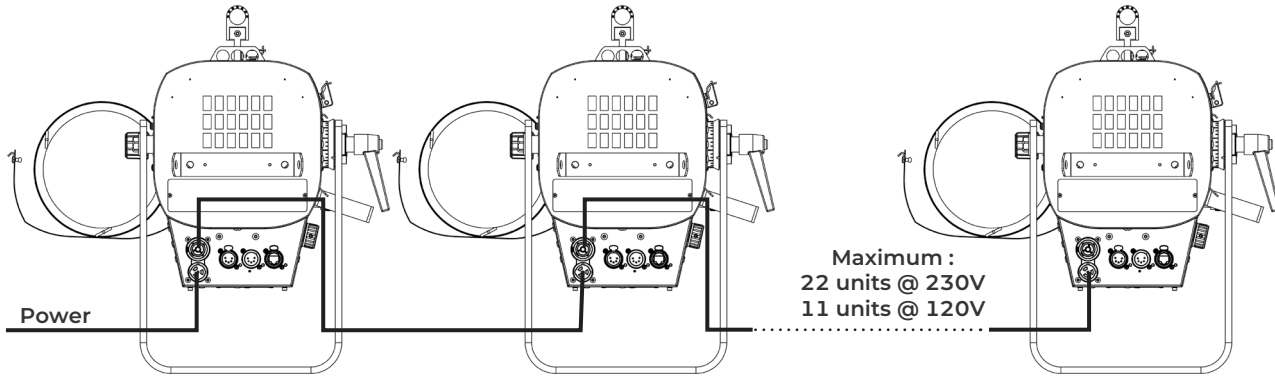
Power supply			
Voltage	Frequency	Input power	Connectors
90 → 277 V	50-60 Hz	0,7 A / 130 W @ 230V 1,15 A / 135 W @ 120V 1,4 A / 135 W @ 100V Max: 1,5A Standby mode: 10W	Neutrik powerCON TRUE1 TOP Input : ref. NAC3FPX-TOP
 <ul style="list-style-type: none"> • Class 1 product. This luminaire must be earthed. • Must be connected directly to AC power. Do not connect to dimmer power. • Automatic mains voltage detection. 			
<p>Daisy chain (with delivered power cable):</p>  <p>Maximum : 22 units @ 230V 11 units @ 120V</p>			

Power cable

Power cable		Connector	Mains plug	Cable type	Cable length	Wiring
1	Standard version	Neutrik® powerCON TRUE1 TOP NAC3FX-W-TOP	CEE7/7	3G1.5 H07RNF	3 m 9.8 ft	Live: Brown Neutral: Blue Ground: Yellow/Green
2	North American version		-	14AWG SJ TYPE (UL/CSA)	1.5 m 4.9 ft	Live: Black Neutral: White Ground: Green

3.3 DATA

3.3.1 DMX 512-A / RDM

Protocol	Input connector	Output connector
USITT DMX 512-A RDM	XLR 5-pin	XLR 5-pin

DATA connectors			
PIN #	DMX	Description	
1	Shielding	Foil & Braided Shield	
2	DMX (-)	1st conductor of 1st twisted pair	
3	DMX (+)	2nd conductor of 1st twisted pair	
4	Not used	1st conductor of 2nd twisted pair	
5	Not used	2nd conductor of 2nd twisted pair	

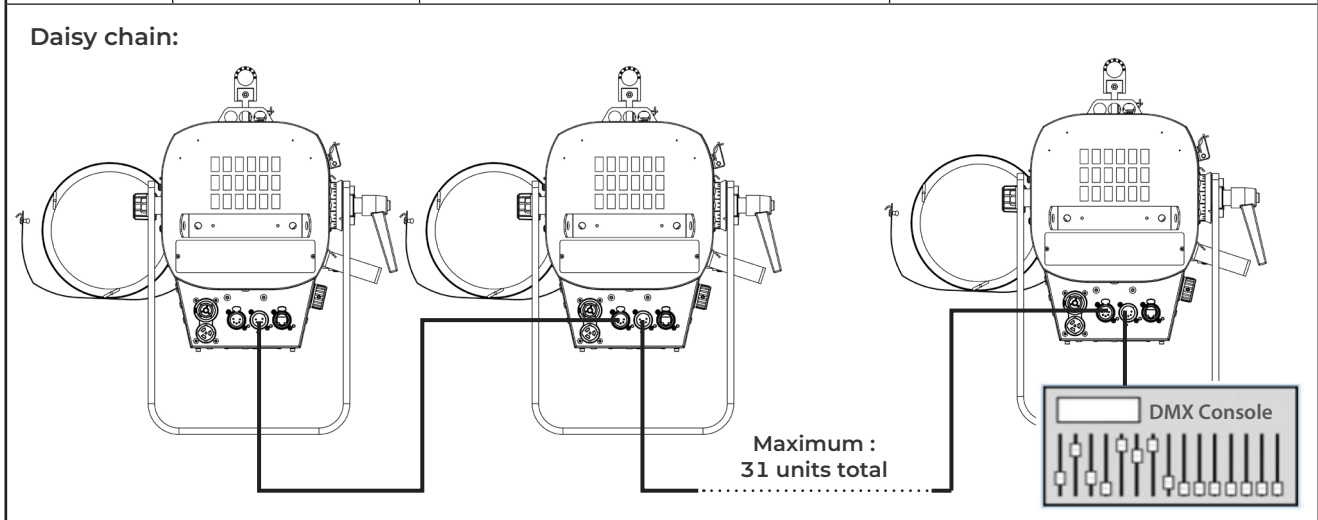

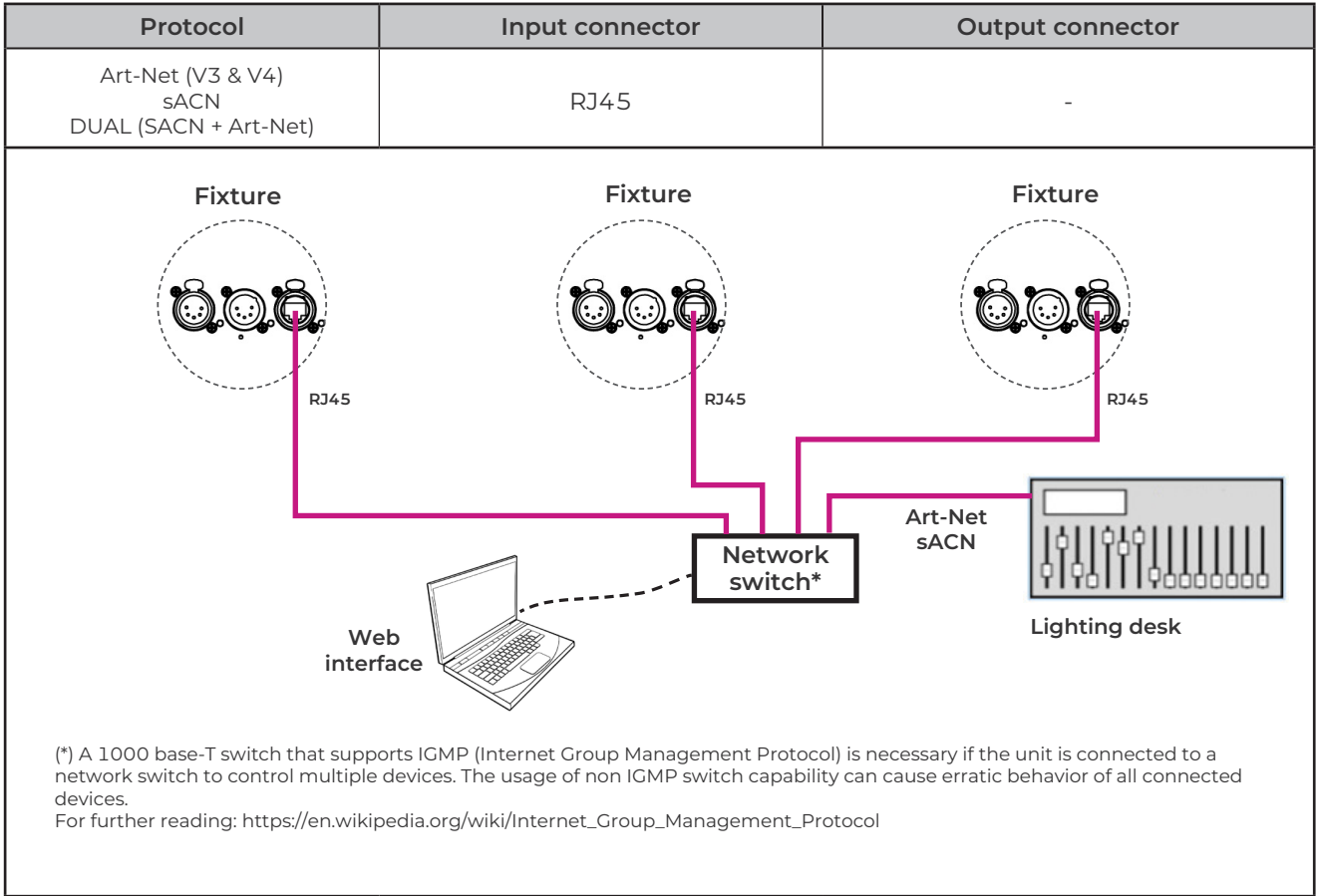

3.3.3 Ethernet / DMX node / DUAL

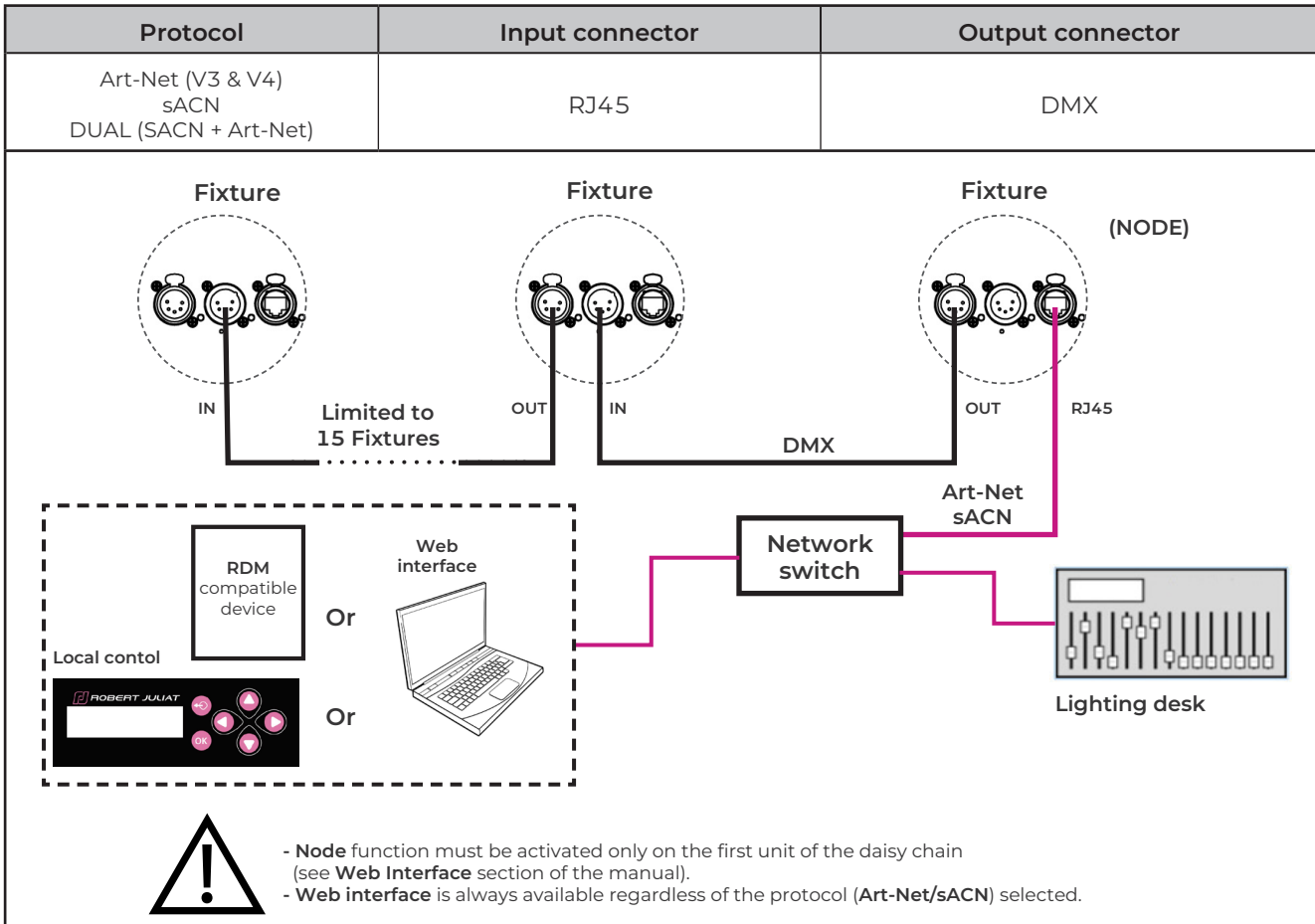

RJ-LED2 FIRMWARE PLATFORM (Node Mode) full manual is available for download at www.robertjuliat.com/LED/PDF_PAGE

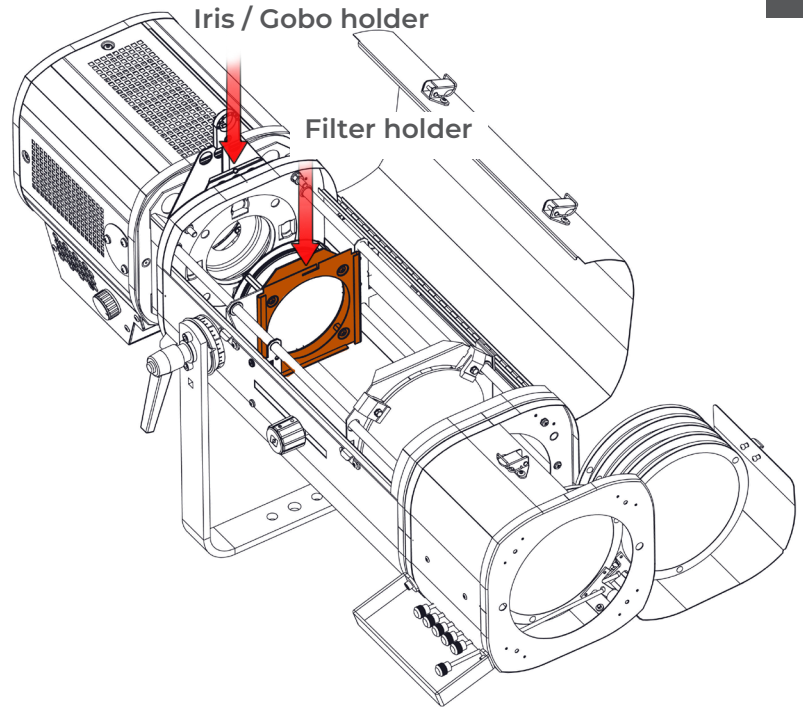

3.4.1 Iris

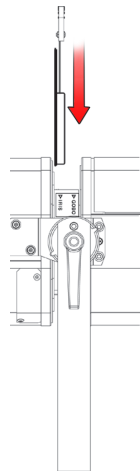
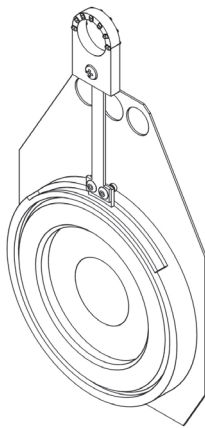

 "Click":
Correctly in place.

3.4.2 Gobo holder

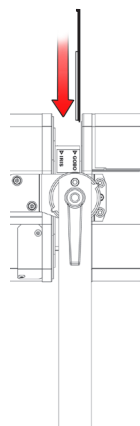
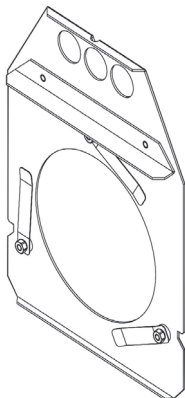

 "Click":
Correctly in place.

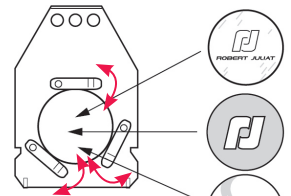

Gobo
For filter dimensions,
see section 4.7

3.4.3 Internal filter holder

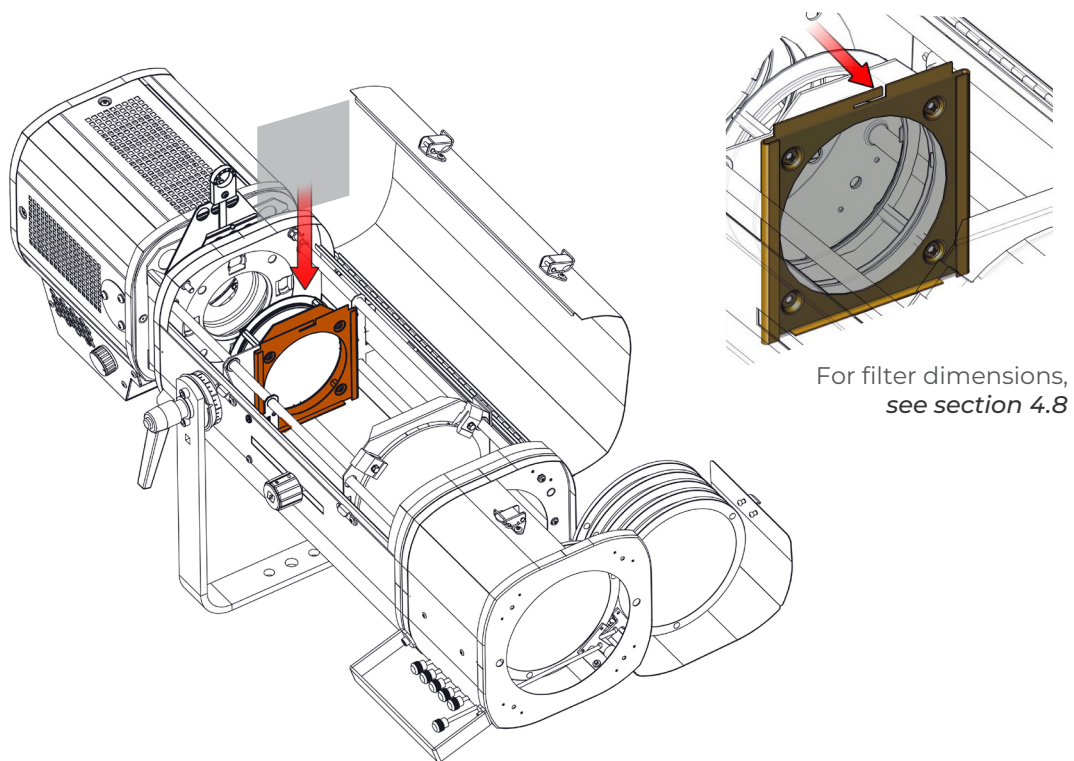

3.4.4 Colour changer unit - push-pull

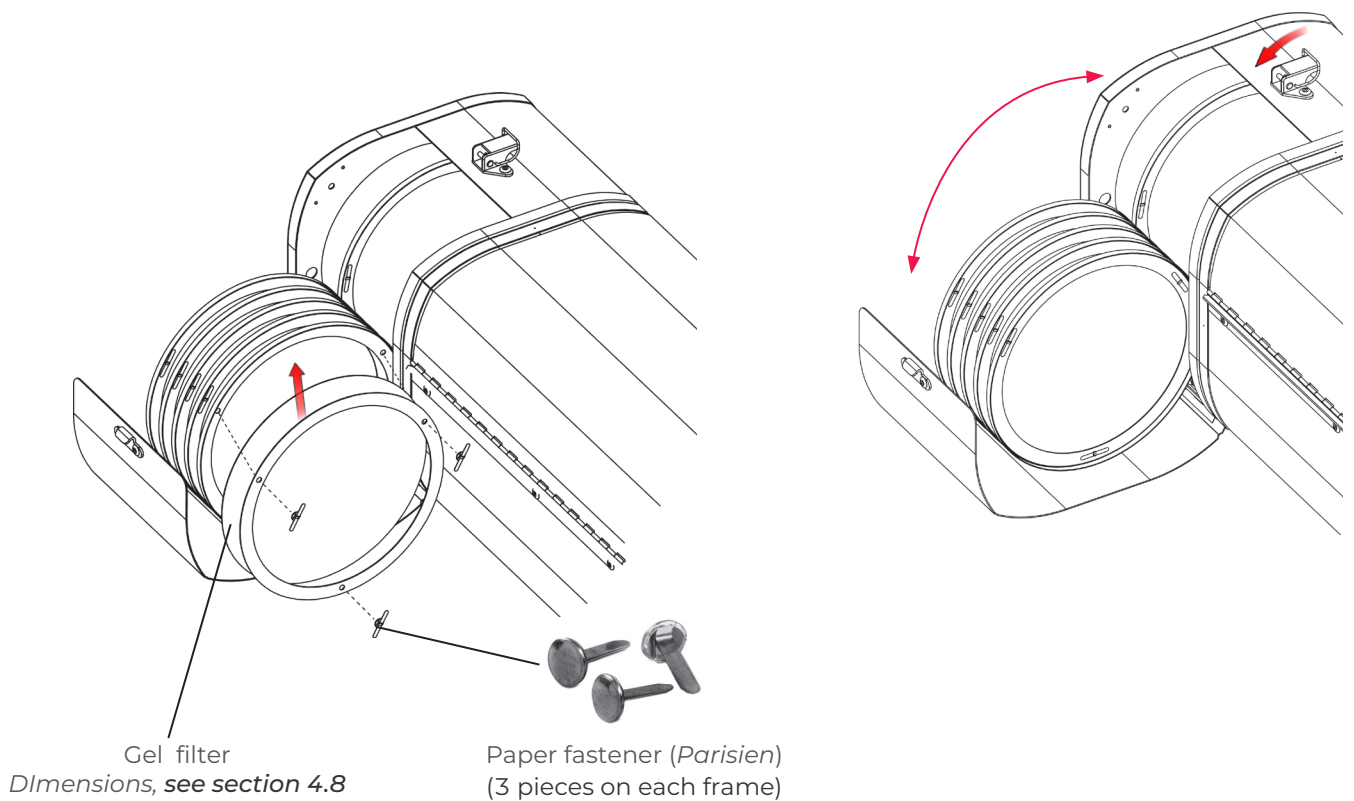

3.4.5 Double slot front cassette for front accessories (option)

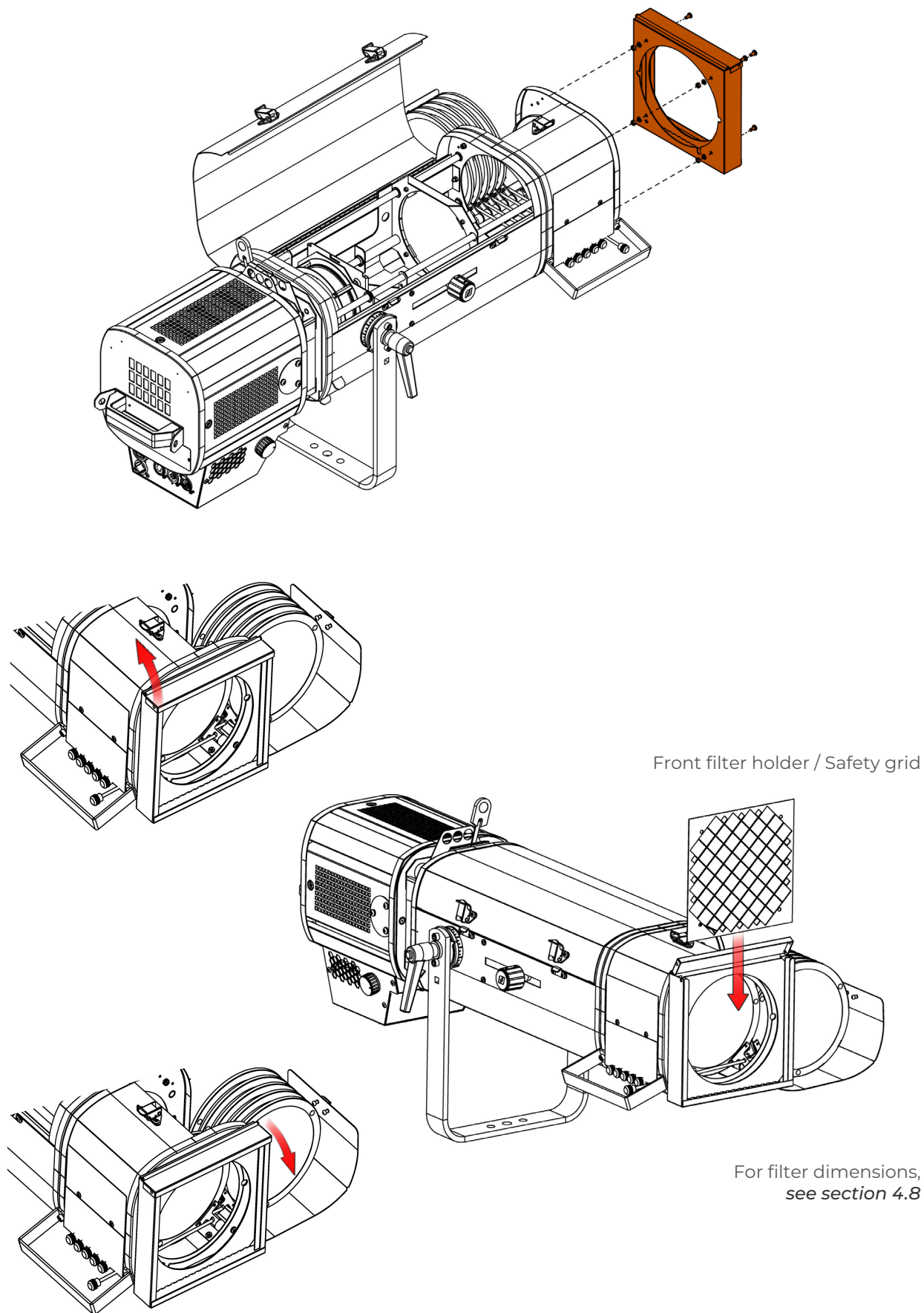

3.4.6 Double-condenser set

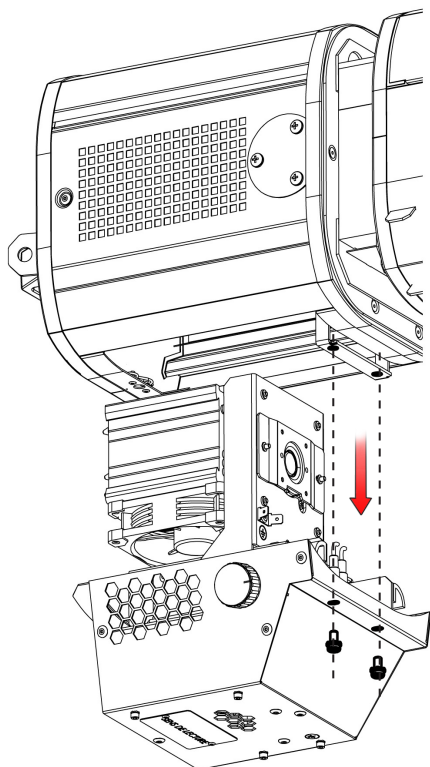

For full procedure, see section 6.1.7

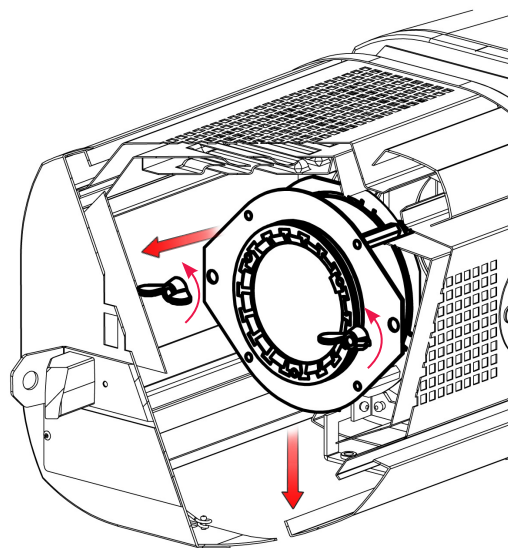

APH68 LED only possible with LED version (not with halogen).

4.1 Light intensity

4.1.1 Range



4.1.2 Control

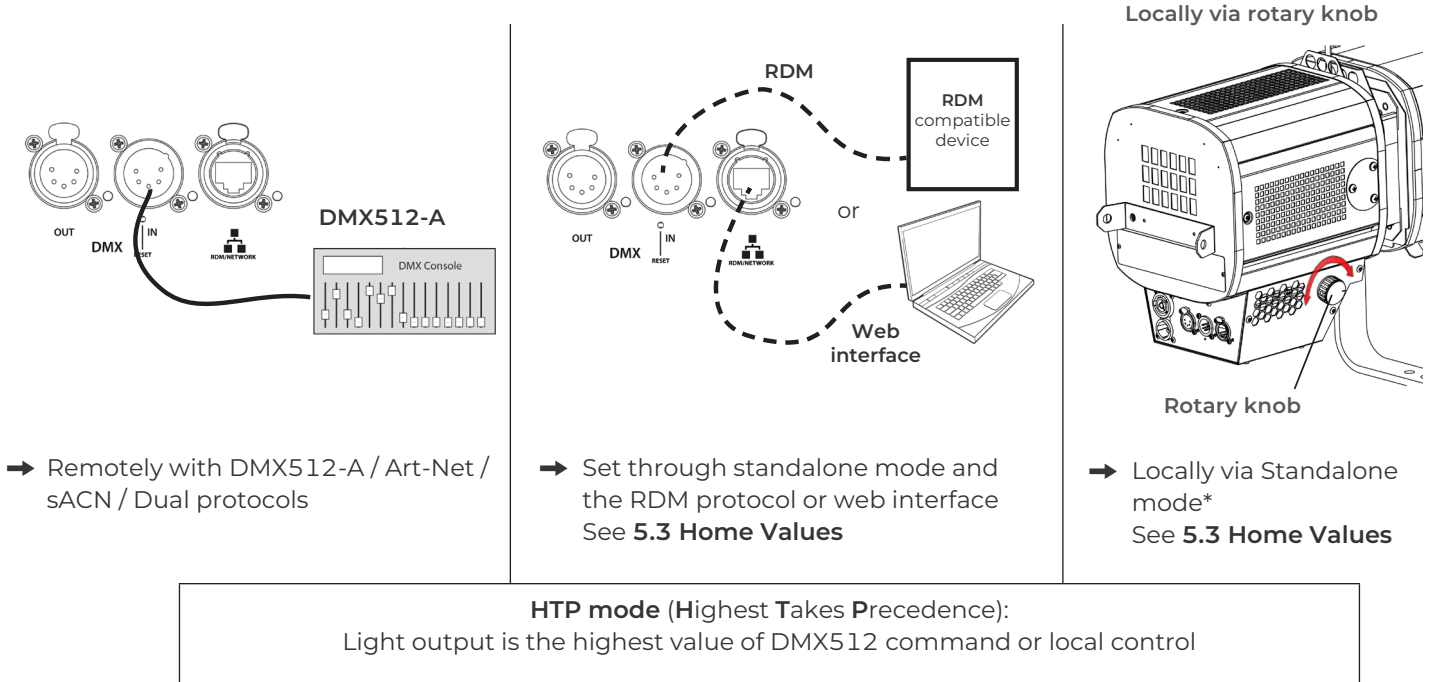

(*) if equipped with display and keyboard option



4.1.3 Parameters

4.1.3.1 Dimming resolution - DMX only

→ Set through RDM protocol, web interface or local control

Resolution	DMX mode
8 bits – 255 steps	1 - 3
16 bits – 65 535 steps	2 - 4

4.1.3.2 Dimming curve

→ Set through RDM protocol, web interface or local control

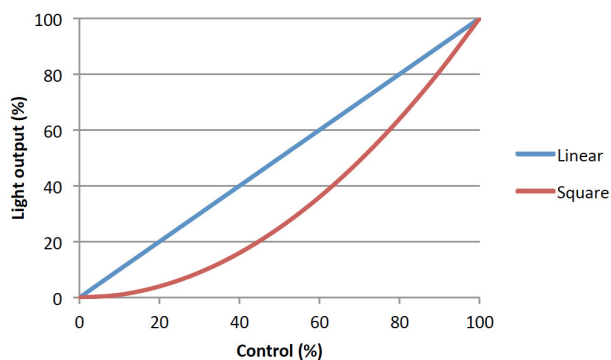

4.1.3.3 Master control

In order to supervise the operator from the console, master control DMX channel can be used. This channel limits the maximum value of the dimmer shutter.

By using this function, it is possible to obtain synchronised fades with several spots or to give intensity limits (minimum and maximum) to the operator. Master is only active when DMX is detected.

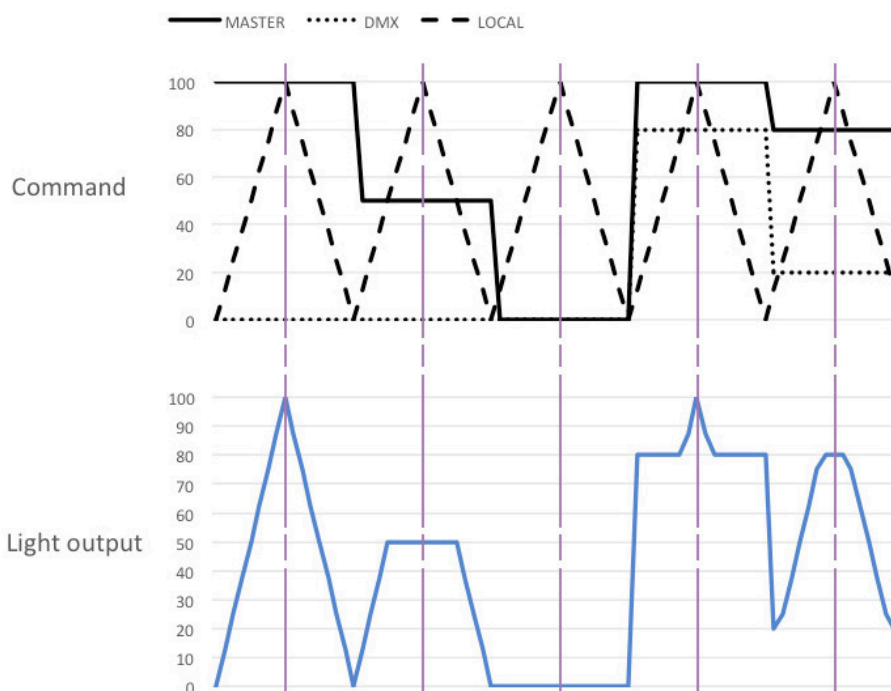

4.1.3.3 Set maximum position

→ Set through RDM protocol, web interface or local control

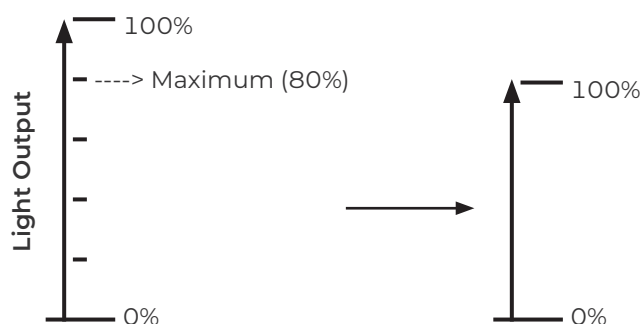

4.1.3.4 Dimming mode

→ Set through RDM protocol, web interface or local control

Mode	Result
Without PWM	Flicker-Free, perfect for filming
PWM 17 kHz	Good dimming quality (Default Value)
PWM 3,2 kHz	Very good dimming

4.2 Strobe

4.2.1 Range

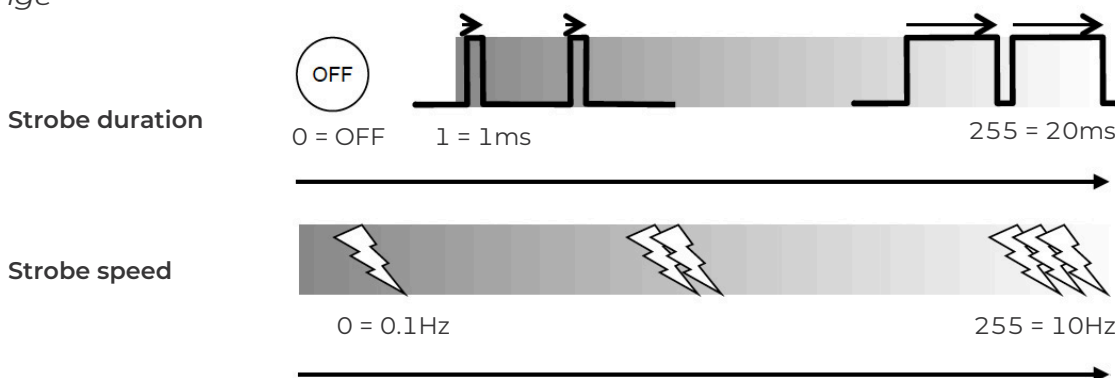

4.2.2 Control

→ Remotely with DMX512-A / Art-Net / sACN / Dual protocols.
 Mode 3 – 4

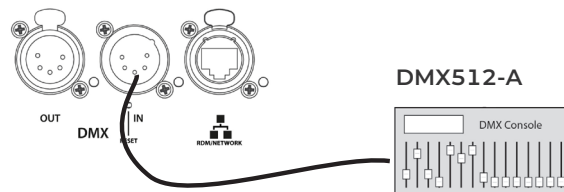

4.3 Response time

4.3.1 Range

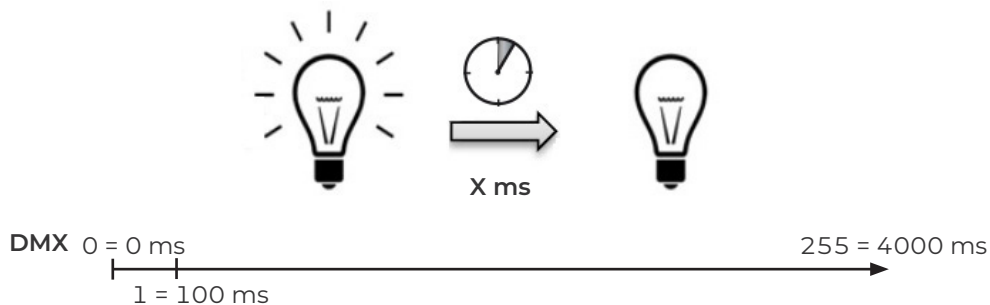

4.3.2 Control

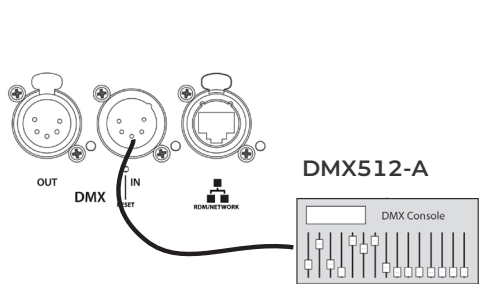

Remotely, with DMX512-A / Art-Net / sACN / Dual protocols Mode 2 – 4 only

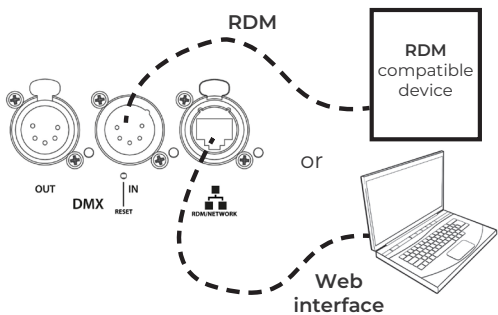

→ Set through RDM protocol or web interface

Mode 1 – 3

Mode	Speed
RAW	OFF
SLOW	700 ms
MEDIUM	470 ms
FAST	350 ms
CUSTOM	0 - 4000 ms

see 5.3 Home Values

Locally*

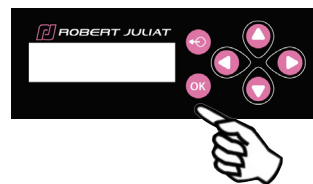

* if equipped with display and keyboard option

→ selection in SETUP/DIMMER/RESPONSE TIME

Mode 1 – 3

Mode	Speed
RAW	OFF
SLOW	700 ms
MEDIUM	470 ms
FAST	350 ms
CUSTOM	0 - 4000 ms

see 5.3 Home Values

4.4 Beam size adjustment

4.4.1 Range

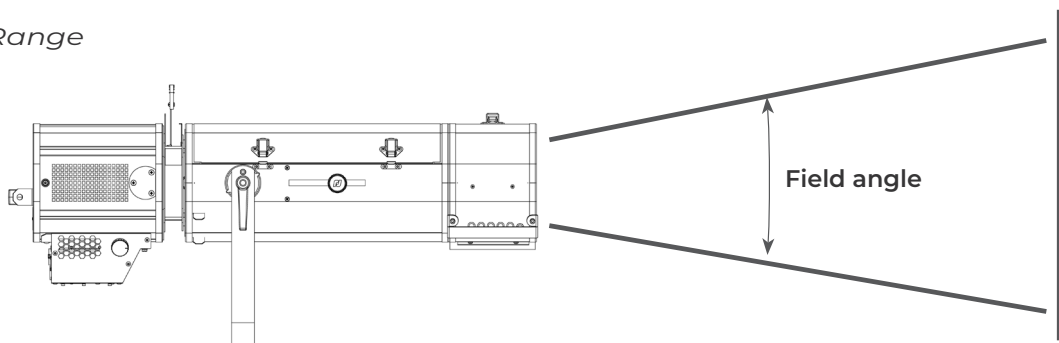

Model	Minimum angle	Maximum angle
1156	10.5°	22.5°

4.4.2 Control

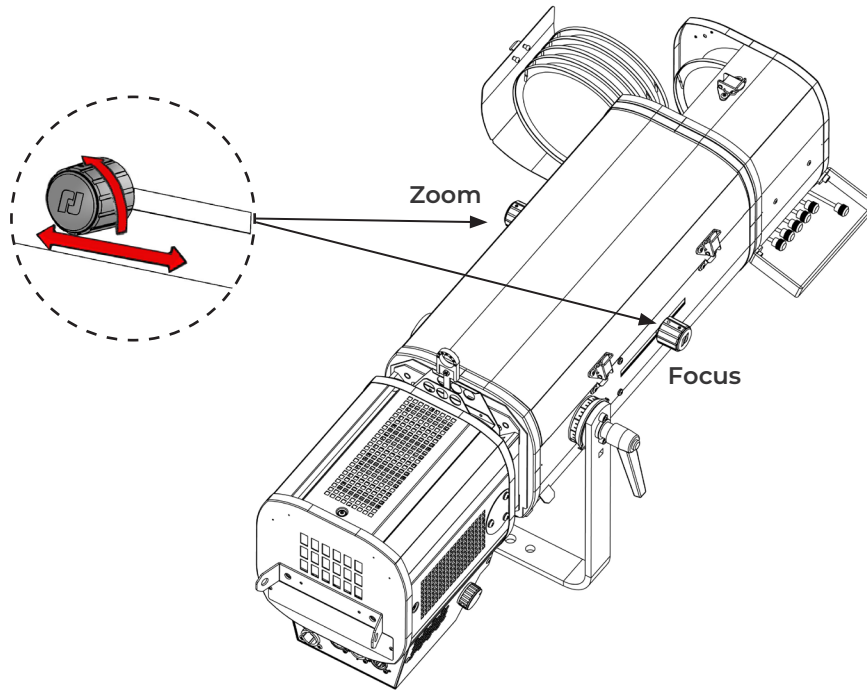

4.5 Orientation

4.5.1 Range

Function	Range
PAN	0 → 360°
<p>TILT</p>	<p>TU = 0 → 38°</p> <p>TD = 0 → 56°</p>

4.5.2 Control

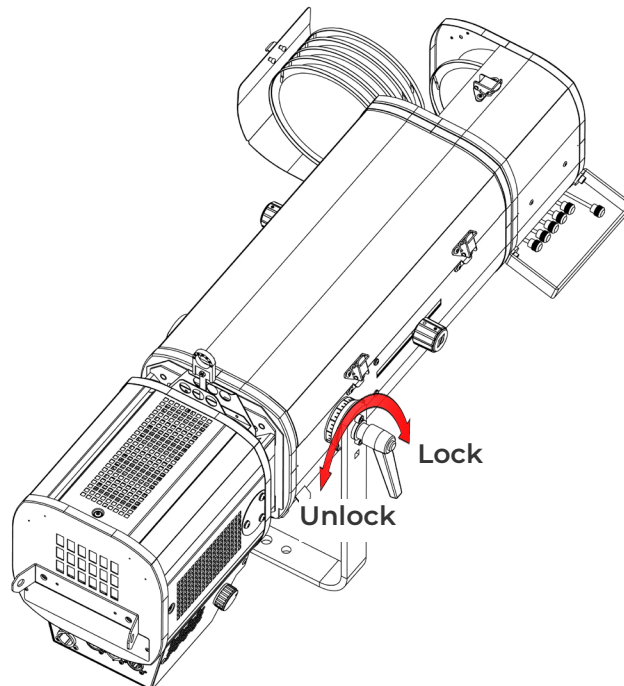

4.6 Iris

4.6.1 Range

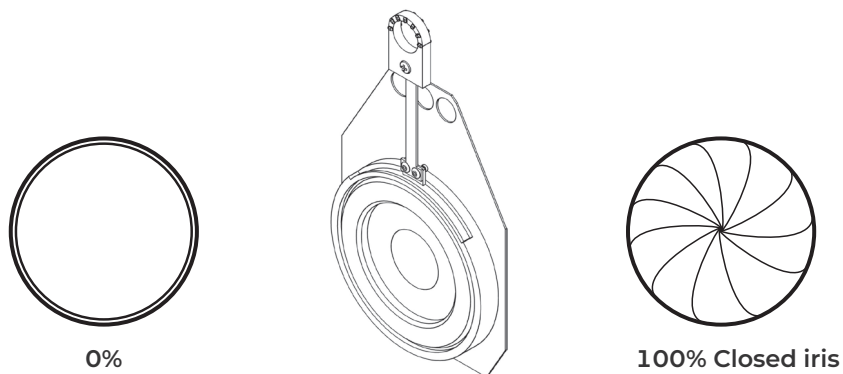

4.6.2 Control

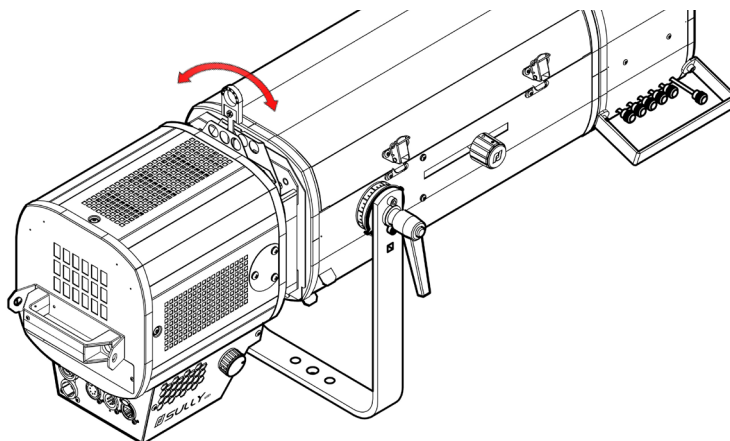

4.7 Gobo

4.7.1 Range

Type	Standard gobo - A size	
Dimensions	<p>100 mm</p> <p>75 mm</p> <p>72 mm Maximum image size</p> <ul style="list-style-type: none"> • Metal • Glass <p><i>Values are in millimeters (mm)</i></p>	
Installation	See 3.4.3	

4.8 Colour

- Fixed colour: place dark colours towards the rear end.

4.8.1 Range

Type	Coloured gel filter	
Dimension	<p>165 mm</p>	
Installation	See 3.4.4	

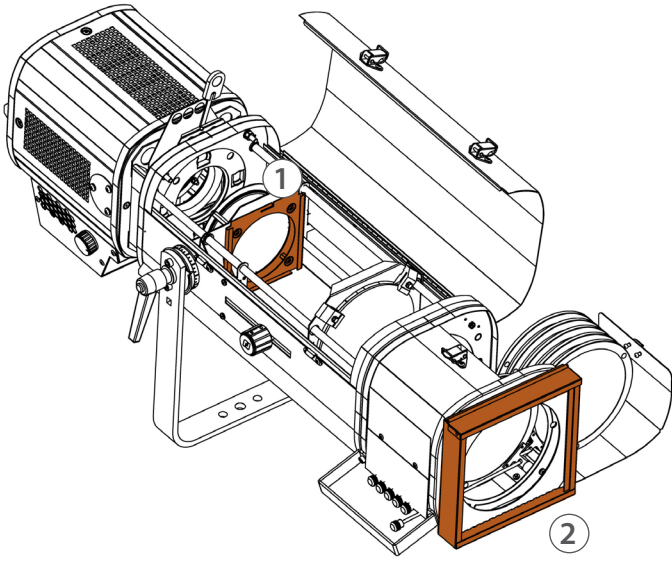
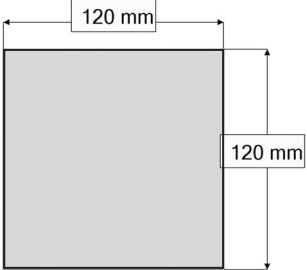
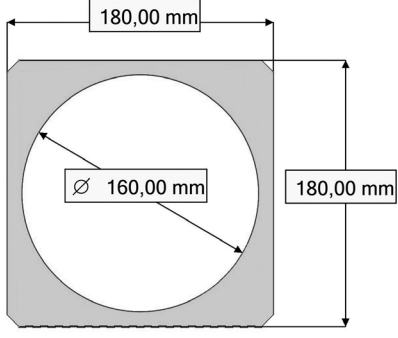
<p>Location</p>		
	<p>1. Internal filter holder</p>	<p>2. Front filter cassette (option)</p>
<p>Type</p>	<p>Frosted or dichroic glass</p>	<p>Coloured gel filter (option)</p>
<p>Dimensions</p>		
<p>Installation</p>	<p>See 3.4.3</p>	<p>See 3.4.5</p>

5 Controls and parameters

5.1 Local display and controls*

5.1.1 Display

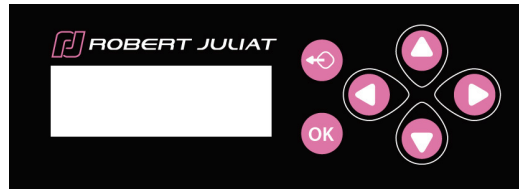

Function	
	Exit the current menu option and/or go back
	Long press for 3 seconds => Access Focus mode
	Enter the current menu option and/or valid
	Scroll through menus and/or Increase data value
	Scroll through menus and/or Decrease data value
	Scroll through menus and/or Increase data value
	Scroll through menus and/or Decrease data value

(*) If equipped with this option

5.1.2 Home screen

Display	Mode	Description
DUAL : NO HOLD LAST NO DMX DIMMER: 00	Home	Main display (home screen)
Diagnostic Nothing to report	 x1 push	Diagnostics
Link status : NOK DHCP : OFF IP 192.168.000.013 MASK 255.255.255.000 GW 192.168.000.001	 x1 push	Network information
FOCUS MODE Remaining... 59s	 Press 3 secs.	Focus mode

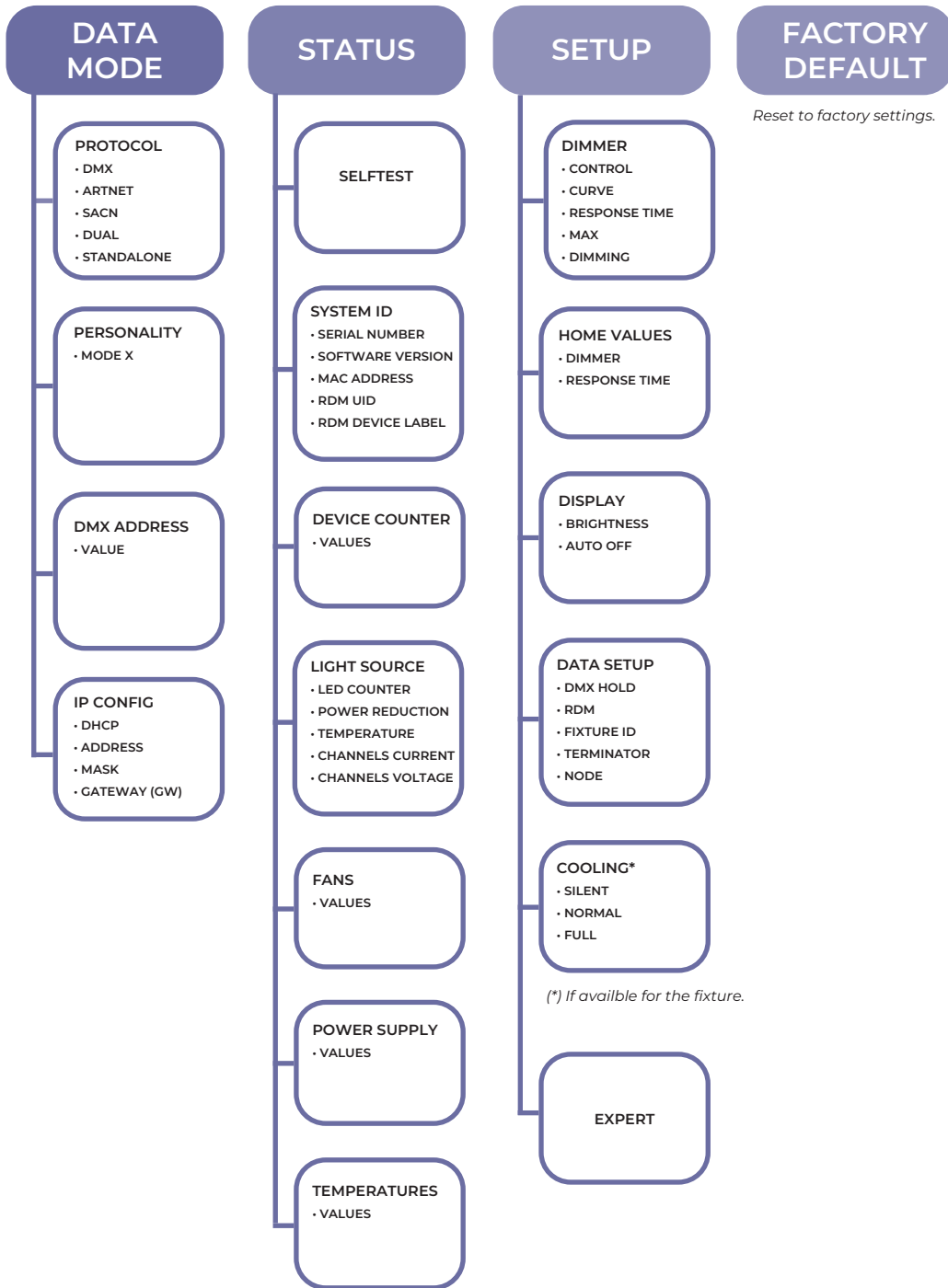

→ Selection in menu: **SETUP / DISPLAY**

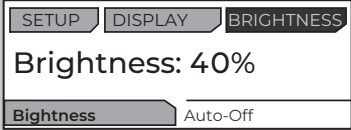
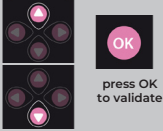
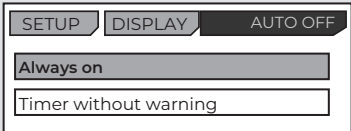
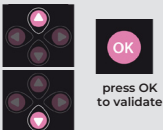
Display	Function	Description
	<p>Brightness</p>	<p>Adjust the intensity of the screen</p> <p>To change value, press buttons:</p> 
	<p>Auto-OFF</p>	<p>To keep the main display (home screen) always ON, select :</p> <p>Always ON Timer without warning Timer with warning</p> <p>Main display turns OFF after 20 seconds</p> 

5.2 DMX512 - A remote control

5.2.1 Protocol

E1.11 - 2008, USITT DMX512-A

5.2.2 Configuration

Set mode through web interface
(see 5.4.4 Web interface)

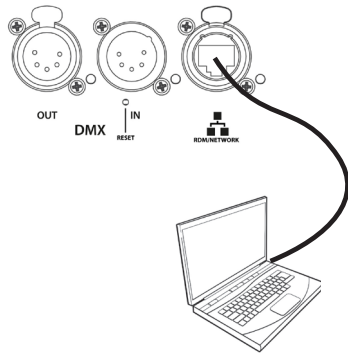

Set mode through RDM protocol

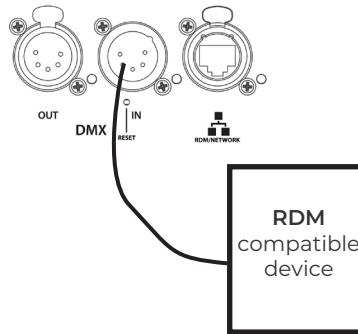

Local control*

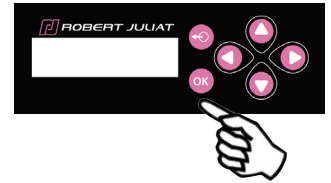

(*) if equipped with display and keyboard option

- 1 - Set DMX address
- 2 - Set personality mode (see 5.2.4. DMX chart)

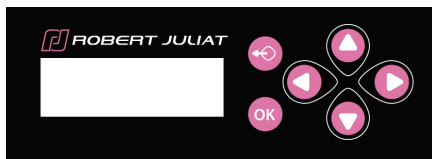

Caution:

Activate DMX in protocol mode beforehand.

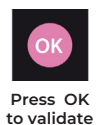
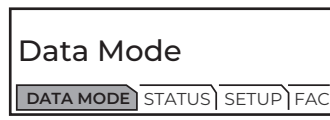

DMX address of the unit from 1 to 512



Selection of the unit personality

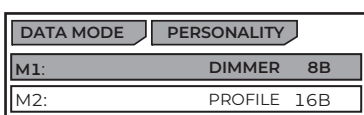
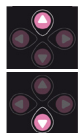

5.2.3 Parameters

5.2.3.1 DMX Hold

➔ Selection in **SETUP / Data Setup / DMX HOLD** menu

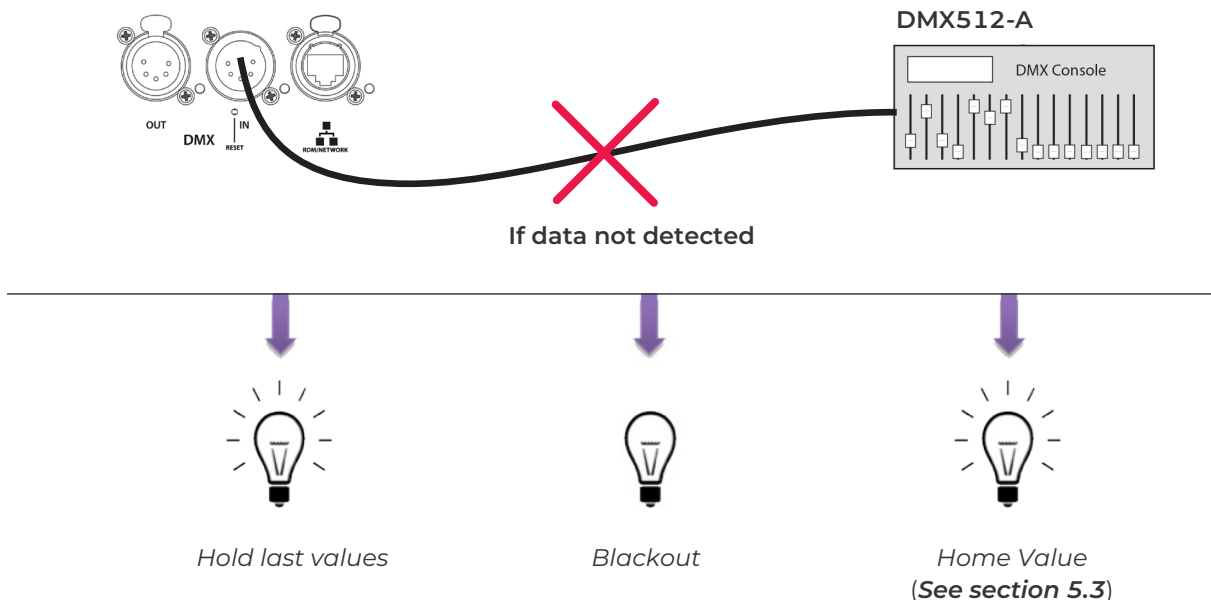

5.2.3.2 Fixture ID

➔ Selection in **SETUP / DATA SETUP / FIXTURE ID** menu

Fixture ID can be set through **web interface** or **RDM protocol** or **local control**

Each unit can be identified by a Fixture ID number
 – Once defined, the Fixture ID is displayed on the Home screen.

Example: Installation with 6 units						
Home screen information	ID1 @ 101	ID2 @ 123	ID3 @ 145	ID4 @ 167	ID5 @ 189	ID6 @ 211
Fixture ID	1	2	3	4	5	6
DMX address	101	123	145	167	189	211

5.2.3.3 Terminator

Mode: Auto

A resistor of 120R is automatically connected to terminate the DMX line as the RS485 standard specifies.

5.2.3.4 Node

On sACN/ArtNet/Dual mode we have the possibility to transmit a DMX/RDM signal protocol on the DMX port (Output). The selection can be done through the menu/Webpage/RDM.

On Dual mode (sACN/ArtRdm) the node feature is automatically selected.

5.2.4 DMX chart

DMX Channel	Mode 1: Dimmer8B	Mode 2: Dimmer16B	Mode 3: Profile8B	Mode 4: Profile16b	Mode 5: Followspot8b	Mode 6: Followspot16b
1	Dimmer	Dimmer	Dimmer	Dimmer	Dimmer	Dimmer
2		Dimmer fine	Strobe duration	Dimmer fine	Master	Dimmer fine
3			Strobe speed	Strobe duration	Strobe duration	Master
4			Response time	Strobe speed	Strobe speed	Master fine
5			Control mode	Response time	Response time	Strobe duration
6				Control mode	Control mode	Strobe speed
7						Response time
8						Control mode

5.2.5 DMX ranges

5.2.5.1 Strobe duration

Range min	Range max	Function
0	0	Strobe OFF
1	255	Strobe ON - 1 ms → 20 ms

5.2.5.2 Strobe speed

Range min	Range max	Function
0	255	Frequency: 0,1 Hz → 10 Hz

5.2.5.3 Response time

Range min	Range max	Function
0	0	OFF
1	255	Response time: 0,1 s → 4 s

5.2.5.4 Control mode*

Range min	Range max	Function
0	0	-
1	10	RDM OFF
11	20	RDM ON
21	30	Fixture Reset
31	40	Dimmer Curve Linear
41	50	Dimmer Curve Square
51	60	Not used
61	70	Not used
71	80	Not used
81	90	Not used
91	100	Not used
101	110	Cooling mode: Silent
111	120	Cooling mode: Normal
121	130	Cooling mode: Full power
131	255	Not used

(*) Function activated after 5 seconds - needs to go back to zero to activate second function.

5.2.6.1 Protocol

ANSI E1.20 – 2010 / ANSI E1.37 - 1

For more information about RDM protocol: <http://www.rdmprotocol.org/>

5.2.6.2 Functions

PID	Description	Standard	Get	Set	Queued_Message	Ack_Timer	VERSION 5.00
Network Management							
00 01	DISCOVERY_UNIQUE_BRANCH	E1.20					✓
00 02	DISCOVERY_MUTE	E1.20		✓			✓
00 03	DISCOVERY_UNMUTE	E1.20		✓			✓
00 15	COMMUNICATION_STATUS	E1.20	✓	✓			✓
Status Collection							
00 20	QUEUED_MESSAGE	E1.20	✓				✓
00 30	STATUS_MESSAGES	E1.20	✓				✓
00 31	STATUS_ID_DESCRIPTION	E1.20	✓				✓
00 32	CLEAR_STATUS_ID	E1.20		✓			✓
00 33	QUEUED_MESSAGE_SENSOR_SUBSCRIBE	E1.20-2023	✓	✓			
RDM Information							
00 50	SUPPORTED_PARAMETERS	E1.20	✓				✓
00 51	PARAMETER_DESCRIPTION	E1.20	✓				✓
Product Information							
00 60	DEVICE_INFO	E1.20	✓			✓	✓
00 70	PRODUCT_DETAIL_ID_LIST	E1.20	✓				✓
00 80	DEVICE_MODEL_DESCRIPTION	E1.20	✓				✓
00 81	MANUFACTURER_LABEL	E1.20	✓				✓
00 82	DEVICE_LABEL	E1.20	✓	✓	✓	✓	✓
00 90	FACTORY_DEFAULTS	E1.20	✓	✓		✓	✓
00 C0	SOFTWARE_VERSION_LABEL	E1.20	✓			✓	✓
00 C2	BOOT_SOFTWARE_VERSION_LABEL	E1.20	✓				✓
DMX512 Setup							
00 E0	DMX512_PERSONALITY	E1.20	✓	✓	✓	✓	✓
00 E1	DMX512_PERSONALITY_DESCRIPTION	E1.20	✓				✓
00 F0	DMX512_STARTING_ADDRESS	E1.20	✓	✓	✓	✓	✓
01 20	SLOT_INFO	E1.20	✓				✓
01 21	SLOT_DESCRIPTION	E1.20	✓				✓
Sensors							
02 00	SENSOR_DEFINITION	E1.20	✓				✓
02 01	SENSOR_VALUE	E1.20	✓				✓
Dimmer Settings							
03 40	DIMMER_INFO	E1.37-1	✓				✓
03 42	MAXIMUM_LEVEL	E1.37-1	✓	✓	✓	✓	✓
03 43	CURVE	E1.37-1	✓	✓	✓	✓	✓
03 44	CURVE_DESCRIPTION	E1.37-1	✓				✓
03 45	OUTPUT_RESPONSE_TIME	E1.37-1	✓	✓	✓	✓	✓
03 46	OUTPUT_RESPONSE_TIME_DESCRIPTION	E1.37-1	✓				✓
03 47	MODULATION_FREQUENCY	E1.37-1	✓	✓	✓	✓	✓
03 48	MODULATION_FREQUENCY_DESCRIPTION	E1.37-1	✓				✓
Power / Lamp Settings							
04 00	DEVICE_HOURS	E1.20	✓				✓
04 01	LAMP_HOURS	E1.20	✓	✓			✓
Display Settings							
05 01	DISPLAY_LEVEL	E1.20	✓	✓	✓	✓	✓

PID		Description	Standard	Get	Set	Queued_Message	Ack_Timer	SULLY 5.00
Control								
10	00	IDENTIFY_DEVICE	E1.20	✓	✓	✓		✓
10	01	RESET_DEVICE	E1.20		✓		✓	✓
10	20	PERFORM_SELFTEST	E1.20	✓	✓	✓	✓	✓
10	21	SELF_TEST_DESCRIPTION	E1.20					✓
RDMnet Management								
07	00	LIST_INTERFACES	E1.37-2	✓				✓
07	01	INTERFACE_LABEL	E1.37-2	✓				✓
07	02	INTERFACE_HARDWARE_ADDRESS_TYPE1	E1.37-2	✓				✓
07	03	IPV4_DHCP_MODE	E1.37-2	✓	✓		✓	✓
07	05	IPV4_CURRENT_ADDRESS	E1.37-2	✓			✓	✓
07	06	IPV4_STATIC_ADDRESS	E1.37-2	✓	✓			✓
07	09	INTERFACE_APPLY_CONFIGURATION	E1.37-2		✓			✓
07	0A	IPV4_DEFAULT_ROUTE	E1.37-2	✓	✓		✓	✓
07	0B	DNS_IPV4_NAME_SERVER	E1.37-2	✓	✓		✓	✓
PID Manufacturer								
85	58	SELFTEST_RESULT	E1.20	✓				✓
85	59	CURRENT_IP_ADDRESS	E1.20	✓			✓	✓
85	5A	CURRENT_NETMASK	E1.20	✓			✓	✓
85	5B	CURRENT_DRIVER_STATUS	E1.20	✓			✓	✓
85	5C	CUSTOM_RESPONSE_TIME_DESCRIPTION	E1.20	✓				✓
85	5D	CUSTOM_RESPONSE_TIME_VALUE	E1.20	✓	✓	✓	✓	✓
85	60	DATA_MODE_DESCRIPTION	E1.20	✓				✓
85	61	DATA_MODE_VALUE	E1.20	✓	✓	✓	✓	✓
85	62	STANDALONE_VALUE_DESCRIPTION	E1.20	✓				✓
85	63	STANDALONE_VALUE	E1.20	✓	✓	✓	✓	✓
85	64	SACN_UNIVERSE_VALUE_DESCRIPTION	E1.20	✓				✓
85	65	SACN_UNIVERSE_VALUE	E1.20	✓	✓	✓	✓	✓
85	66	ARTNET_UNIVERSE_VALUE_DESCRIPTION	E1.20	✓				✓
85	67	ARTNET_UNIVERSE_VALUE	E1.20	✓	✓	✓	✓	✓
85	68	SERIAL_DESCRIPTION	E1.20	✓				✓
85	69	SERIAL	E1.20	✓	✓	✓		✓
85	6A	DMX_HOLD_DESCRIPTION	E1.20	✓				✓
85	6B	DMX_HOLD	E1.20	✓	✓	✓	✓	✓
85	6C	COMMAND_LOCK_DESCRIPTION	E1.20	✓				✓
85	6D	COMMAND_LOCK_VALUE	E1.20	✓	✓	✓	✓	✓
85	6E	DRIVER_CALIBRATE_DESCRIPTION	E1.20	✓				✓
85	6F	DRIVER_CALIBRATE_VALUE	E1.20	✓	✓	✓	✓	✓
85	70	NODE_DESCRIPTION	E1.20	✓				✓
85	71	NODE_VALUE	E1.20	✓	✓	✓	✓	✓
85	72	TERMINATOR_DESCRIPTION	E1.20	✓				✓
85	73	TERMINATOR	E1.20	✓	✓	✓	✓	✓
85	74	DMX_ERROR_COUNTER_DESCRIPTION	E1.20	✓				✓
85	75	DMX_ERROR_COUNTER	E1.20	✓	✓	✓	✓	✓

5.3 Home values & Standalone

“Home values” represent a selection of parameters manually entered into the device via the keypad to produce a defined lighting effect and dimming behavior.

These Home values can be set in the following modes:

Functions *	Mode 1: Dimmer8B	Mode 2: Dimmer16B	Mode 3: Profile8B	Mode 4: Profile16b	Mode 5: Followspot8b	Mode 6: Followspot16b	Standalone **
Dimmer	DMX	DMX	DMX	DMX	DMX	DMX	HOME VALUE
Response Time	HOME VALUE	HOME VALUE	DMX	DMX	DMX	DMX	HOME VALUE
Dimmer Master	HOME VALUE	HOME VALUE	HOME VALUE	HOME VALUE	DMX	DMX	HOME VALUE

If the function is not controlled by DMX, the Home value is automatically activated.

(*) Functions are displayed according to the selected mode (Mode 1-2-3-4-5-6).

- In the case of using one or more functions in Mode 1 / 2 / 3 / 4 / 5 / 6
Data mode → personality → Mode 1 / Mode 2 / Mode 3 / Mode 4 / Mode 5 / Mode 6

() Defines a standalone operating mode in the following cases:**

- As default values when used without data Data mode → Protocol → Standalone

5.4 Network

Our network stack can handle several flows of protocol at the same time.

Protocol always available:

- Web page to set up parameters - *See section 5.4.4*
- LLRP (Low Level Recovery Protocol) for IP network configuration - *See section 5.4.5*

A selection of Protocols dedicated to lighting:

- Art-Net V4 - *See section 5.4.1*
- sACN - *See section 5.4.2*
- Dual: Sacn + Art-RDM (DMX512 data signal + RDM) - *See section 5.4.3*

From July 2024 the Robert Juliat equipment based on RJ LED2 platform is configured as follows:

- DHCP (**D**ynamic **H**ost **C**onfiguration **P**rotocol - **RFC1531**) ON
→ <https://www.rfc-editor.org/rfc/rfc1531>
- Zeroconf (**Z**ero-**C**onfiguration **N**etworking – **IPv4LL/APIPA – RFC3927**) ON
→ <https://www.rfc-editor.org/rfc/rfc3927>

IP Addressing of Parameters - *See section 5.1.2*

Default:

- At startup, the device’s IP address is set to 000.000.000.000 with a subnet mask of 000.000.000.000
- After connecting to the network, the device awaits the assignment of an IP address and subnet mask by the DHCP server.
- If there is no DHCP server, a unique IP address and subnet mask are automatically assigned.
IP : 169.254.XXX.XXX Mask : 255.255.0.0

Most personal computers are configured with DHCP and Zeroconf enabled, so the IP address defaults to 169.254.X.X with a subnet mask of 255.255.0.0.

When connected to a Robert Juliat device, since the IP address/mask range are in the same class, network communication works seamlessly.

This configuration was chosen to make it easier for non-IT technicians.

Static IP:

It's possible to configure a static IP address, but be sure to select a unique IP address with the correct subnet mask.

Configuration can be done via the Web Page, RDM, LLRP, Art-Net, or locally.

Default IP Address:

When DHCP mode is OFF and no static IP address has been selected, the device will default to a Class A IP address of 2.XXX.XXX.XXX with a subnet mask of 255.0.0.0.

This address can be found on a label near the ID plate or by pressing the right arrow on the local control.

Default Settings:

DHCP = OFF

Address = 2.XXX.XXX.XXX

Mask = 255.0.0.0

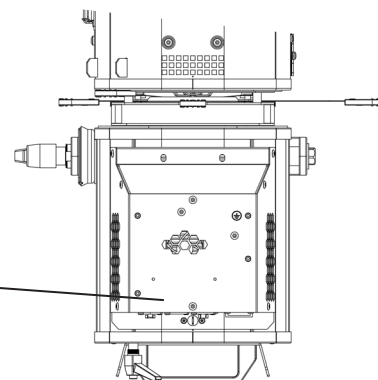
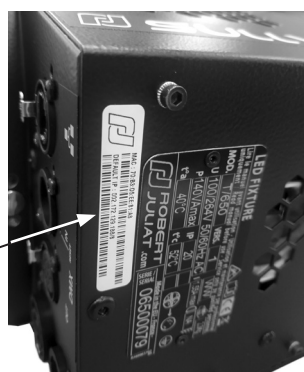

Changing the Controlling Computer's IP Address:

- The IP address and subnet mask of both the fixture and the computer must be on the same network class.
- The computer's IP address must be different.
- Refer to your operating system's support to modify IPv4 settings:
 - Change your IP address on Windows
 - ➔ <https://support.microsoft.com/en-us/windows/change-tcp-ip-settings-bd0a07af-15f5-cd6a-363f-ca2b6f391ace>
 - Change your IP address on Mac
 - ➔ <https://support.apple.com/en-ae/guide/mac-help/mh14129/mac>

Example: Using the fixture's default IP address

- 1 - Computer IP address: 2.2.2.2
- 2 - Computer subnet mask: 255.0.0.0

5.4.1.1 Protocol

Artistic Licence Art-Net v4.

For more information about Art-Net protocol: <http://art-net.org.uk/>

5.4.1.2 Configuration

Set mode through Web interface
(see 5.4.4 Web interface)

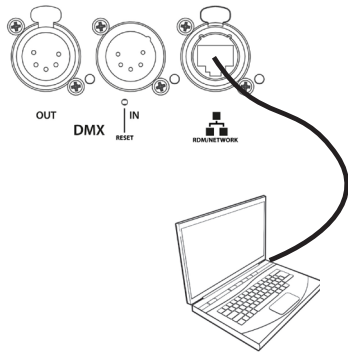

Set mode through RDM
protocol

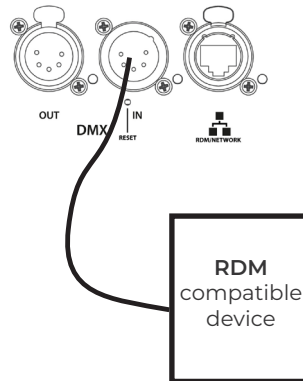

Local control*

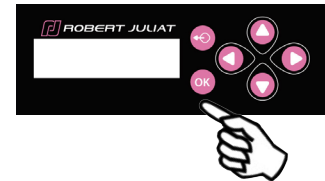

(* if equipped with display and keyboard option)

- 1 - If necessary, change IP settings
- 2 - Set Art-Net Universe
- 3 - Set DMX address
- 2 - Set personality mode (see 5.2.4 DMX chart)



Caution:
(*) Activate Art-Net in protocol mode beforehand.

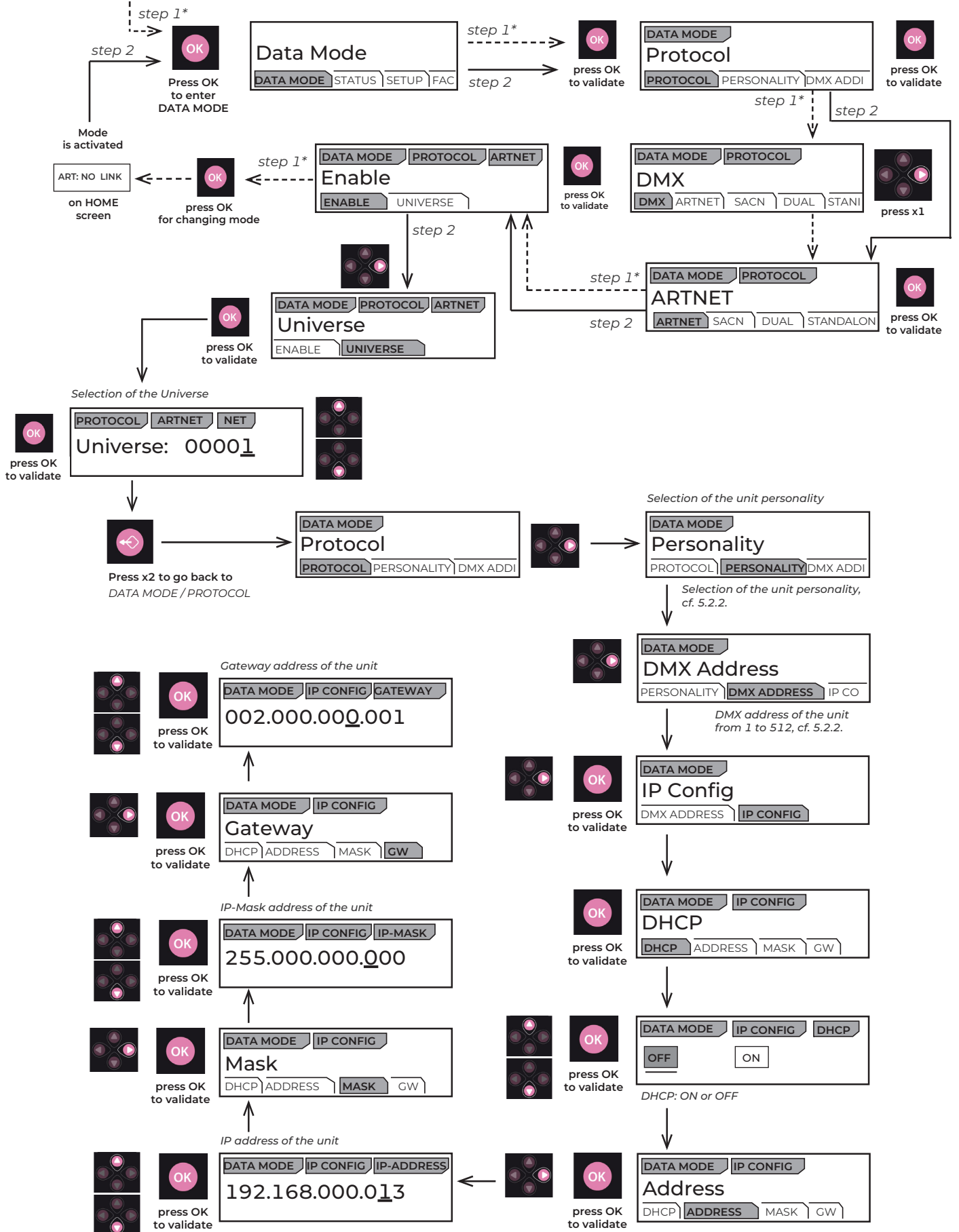

5.4.2.1 Protocol

ANSI E1.31 – 2009 sACN (Streaming-ACN)

5.4.2.2 Configuration

Réglage via interface web
(see 5.4.4 Web interface)

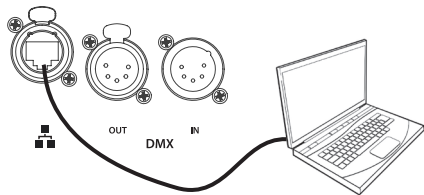

Mode de réglage via protocole RDM

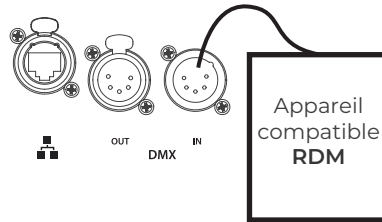

Localement*

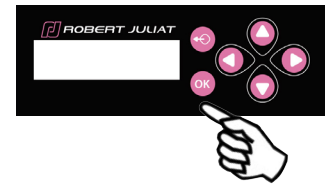

(*) if equipped with display and keyboard option

- 1 - If necessary, change IP settings
- 2 - Set sACN universe
- 3 - Set DMX address
- 2 - Set personality mode (see 5.2.4 DMX chart)



Caution:

(*) Activate sACN in protocol mode beforehand.

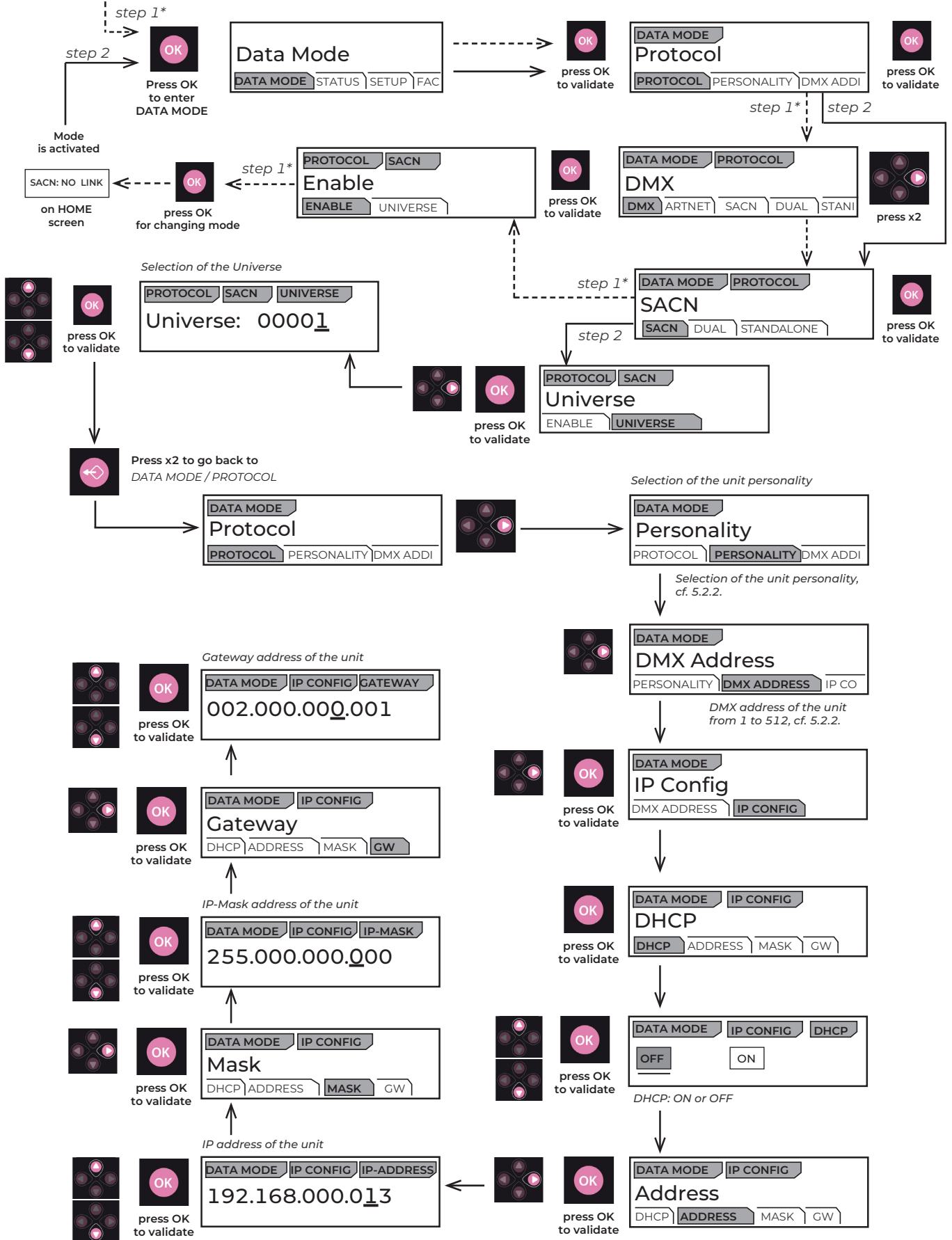

5.4.3.1 Protocol

Dual Mode: Available only on an Ethernet network

It allows to send a DMX 512 signal through a sACN data stream and at the same time to use an Artnet/ArtRdm data stream to control, set and monitor the equipment via RDM.

This mode can be set by Web interface or the local control screen.

5.4.3.2 Configuration

Set mode through Web interface
(see 5.4.4 Web interface)

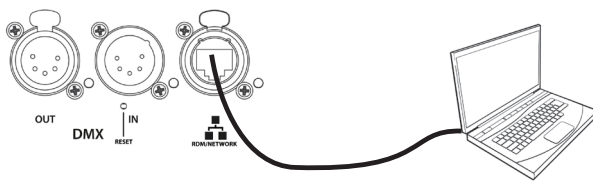

Set through local control*

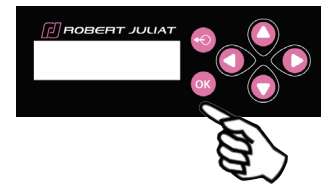

(*) if equipped with display and keyboard option

- 1 - If necessary, change IP settings
- 2 - Set DUAL universe
- 3 - Set DMX address
- 4 - Set personality mode (see 5.2.4 DMX chart)

5.4.4.1 Control

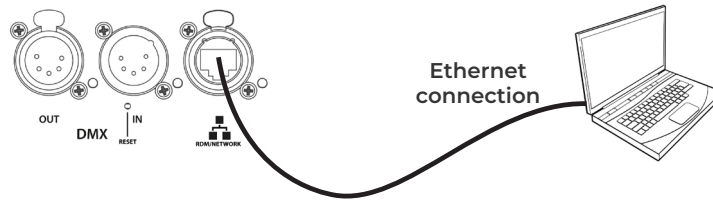

The fixture must be connected to a compatible network or directly linked to a computer with an RJ45 Ethernet cable.

The fixture's IP address: **see section 5.4. Network**

5.4.4.2 Connection to the Web interface

- 1 - Open a web browser (Microsoft Edge, Firefox, Apple Safari...)
- 2 - Enter the fixture's IP address in the browser's address bar
 - "00X" is read as "X".
 - Never type a zero (0) before the numbers XX or X (**see 5.4**)
- 3 - The HOME page will appear, and all settings can now be viewed and modified.

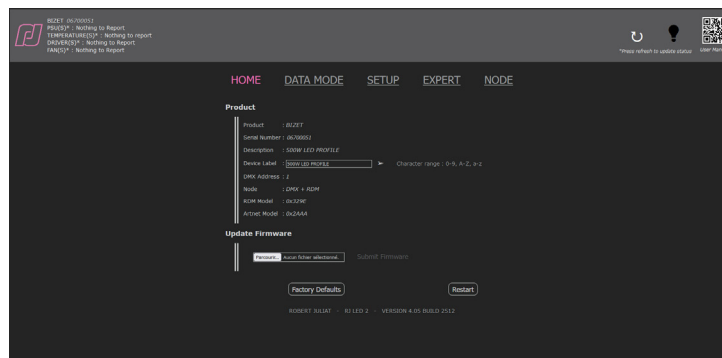

HOME Page

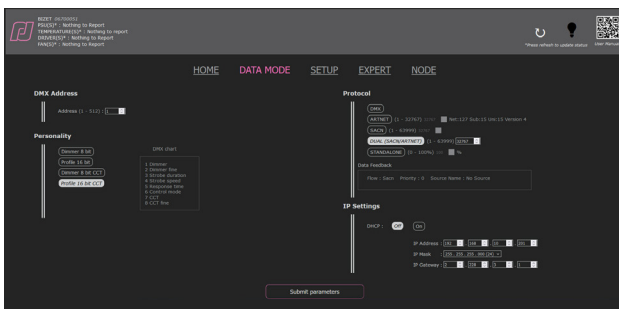

DATA MODE Page

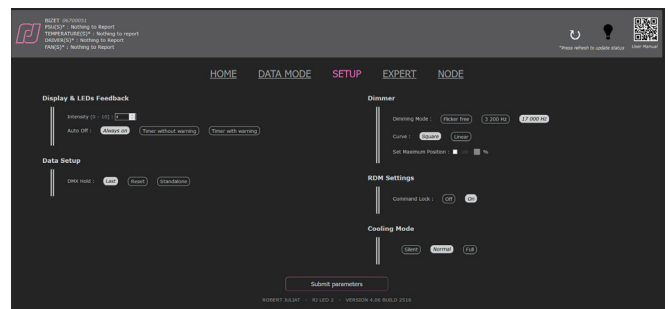

SETUP Page

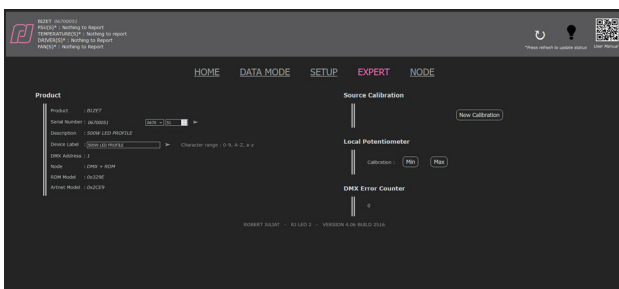

EXPERT Page, password-protected (1280).

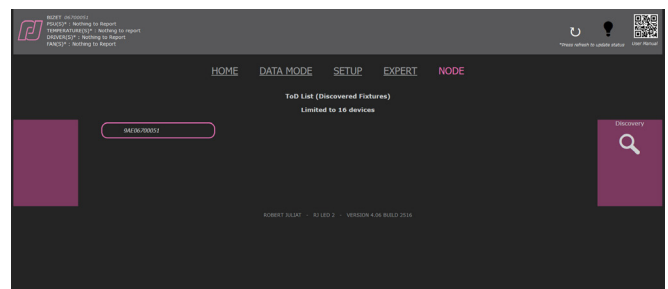

NODE Page

UID* list of devices detected by RDM on the DMX OUT link; the first UID is the fixture.

(*) UID : RDM Unique Identifier

LLRP is a multicast protocol that facilitates basic IP configuration. It is part of the ESTA E1.33 RDMnet standard.

LLRP can be used for the initial configuration of networked equipment. It provides a low-level mechanism for discovering and configuring the network parameters of devices, including IP settings and basic RDMnet configuration settings.

LLRP Targets expose these parameters for configuration and respond to discovery requests from LLRP Managers. Once an LLRP Manager discovers one or more LLRP Targets, it can use LLRP to send RDMnet commands to retrieve or modify these parameters.

A SOLUTION FOR INCORRECT OR UNKNOWN IP CONFIGURATION

Network connectivity issues are often caused by misconfigured network addresses, with improperly configured subnet masks being the most common problem.

LLRP uses two multicast IP addresses, enabling communication even when all other network communication has failed.

Since multicast addresses are unaffected by a misconfigured subnet mask, LLRP provides an efficient and reliable solution to recover from network misconfiguration.

In summary, LLRP simplifies the process of identifying and configuring the IP addressing of LLRP-compatible devices on your network.

All Robert Juliat equipment based on the RJ LED2 platform includes LLRP functionality.

Two LLRP Manager software tools are available for free:

- DMXworkshop by Wayne Howell from Singularity (UK): <https://singularity-uk.com/product/dmx-workshop/>

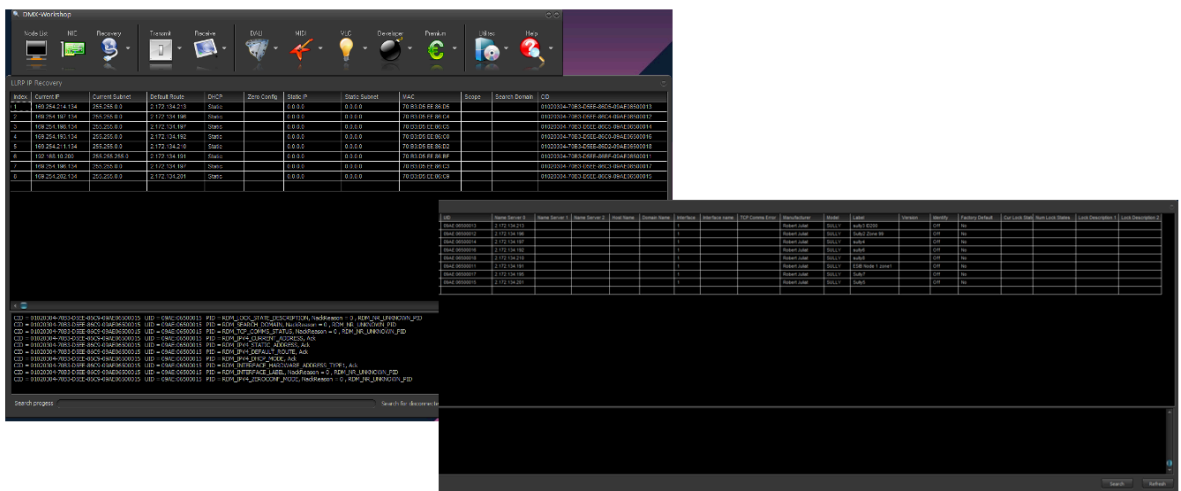

- CLU/Netron from Obsidian : <https://obsidiancontrol.com/netron-clu>



5.5 LEDs Feedback

5.5.1 Trouble shooting

• During unit initialisation (power up) – up to 5 seconds:

1 DMX OUT	2 DMX IN	3 Network	Description
Ⓟ	Ⓟ	Ⓟ	Unit OFF
Ⓡ	Ⓡ	Ⓡ	Unit error
Ⓢ	Ⓢ	Ⓢ	Unit has been reset successfully
Ⓟ	Ⓟ	Ⓡ or Ⓢ or Ⓟ	RDM protocol activated

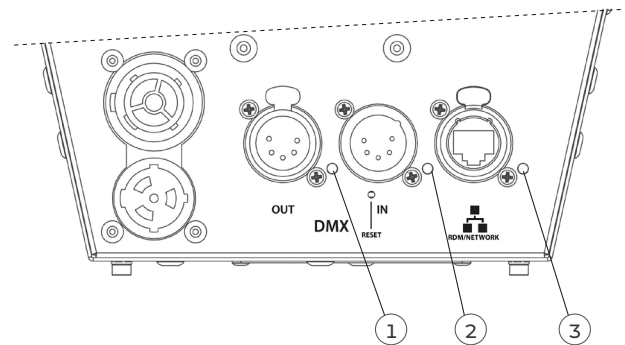

• After initialisation - Node mode "OFF":

1 DMX OUT	2 DMX IN	3 Network	Description
Ⓟ	Ⓟ	Ⓟ	Display auto-off
Ⓟ		Ⓡ	No ethernet
Ⓟ	Ⓢ	Ⓢ	Ethernet detected (link)
Ⓟ	Ⓢ	Ⓟ	Ethernet detected + data
Ⓟ		Ⓡ	No ethernet
Ⓟ	Ⓟ	Ⓢ	Ethernet detected (link)
Ⓟ	Ⓟ	Ⓟ	Ethernet detected + data
Ⓟ		Ⓡ	No ethernet
Ⓟ	Ⓡ	Ⓢ	Ethernet detected (link)
Ⓟ	Ⓡ	Ⓟ	Ethernet detected + data
Ⓡ	Ⓡ	Ⓡ	Unit error
Ⓟ			Terminator ON

• After initialisation - Node mode "ON":

1 DMX OUT	2 DMX IN	3 Network	Description
Ⓟ		Ⓟ	Display auto-off
		Ⓡ	No ethernet
Ⓢ	Ⓢ	Ⓢ	Ethernet detected (link)
Ⓢ	Ⓢ	Ⓟ	Ethernet detected + data
		Ⓡ	No ethernet
Ⓟ	Ⓢ	Ⓢ	Ethernet detected (link)
Ⓟ	Ⓢ	Ⓟ	Ethernet detected + data
		Ⓡ	No ethernet
Ⓡ	Ⓢ	Ⓢ	Ethernet detected (link)
Ⓡ	Ⓢ	Ⓟ	Ethernet detected + data
Ⓡ		Ⓡ	Unit error

5.5.2 Parameters

5.5.2.1 Intensity

➔ Set through RDM protocol, web interface or local control (option)

Mode	Description
Display level	Adjust the intensity of the feedback LEDs

5.5.2.2 Auto-OFF

➔ Set through RDM protocol, web interface or local control (option)

Mode	Description
Always ON	Feedback LED, always ON
Timer without warning	Feedback LED OFF after 20 seconds
Timer with warning	Feedback LED OFF after 20 seconds, ON , if warning information occurs

6.1 Preventive maintenance

6.1.1 Frequency

General maintenance should be performed at least once a year or more frequently if the equipment is operated in adverse conditions (smoke, heat, humidity, touring, etc.).

6.1.2 General cleaning

Remove dust from the unit.

6.1.3 General visual check

- No trace of heat.
- No loose contacts.
- No missing parts.
- Tighten mechanical assemblies (screws, bolts and nuts, etc.).

6.1.4 LED source



- Do not touch the surface of the LED source (no contact with your hands or any tools).
- Do not put compressed air directly on the source.
- Contact a certified RJ distributor in case of residuals or other objects located on the surface of the LED source.

6.1.5 Optics

- Only use solutions containing alcohol to clean optical parts (lenses).
- To clean the optical parts, use a soft cloth in combination with distilled water or isopropyl alcohol recommended for coated optics. Do not use any cleaning product that contains solvents or abrasives, as these can cause surface damage.
 - Dry with a soft lint-free cloth.

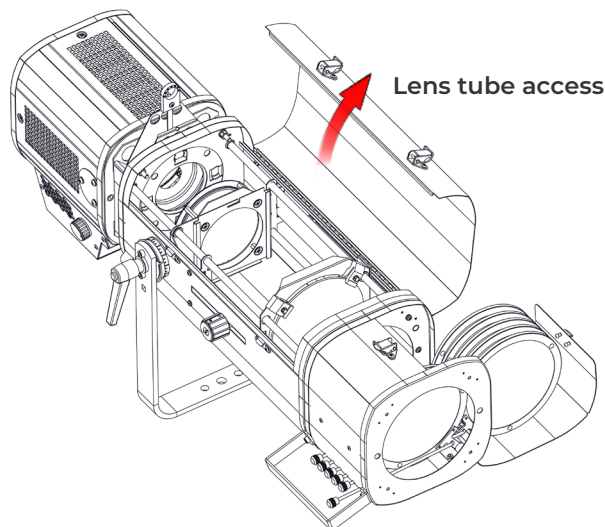

6.1.6 LED house cleaning

Inner parts & lens holder access:

- To clean the optical parts, use a soft cloth in combination with distilled water or isopropyl alcohol recommended for coated optics. Do not use any cleaning product that contains solvents or abrasives, as these can cause surface damage.
- Dry with a soft lint-free cloth.
- The double condenser system (aspheric and biconvex lenses) can easily be removed, without tools, by removing the two M6 nuts. The complete holder can then be removed for cleaning, *see section 3.4.2.*

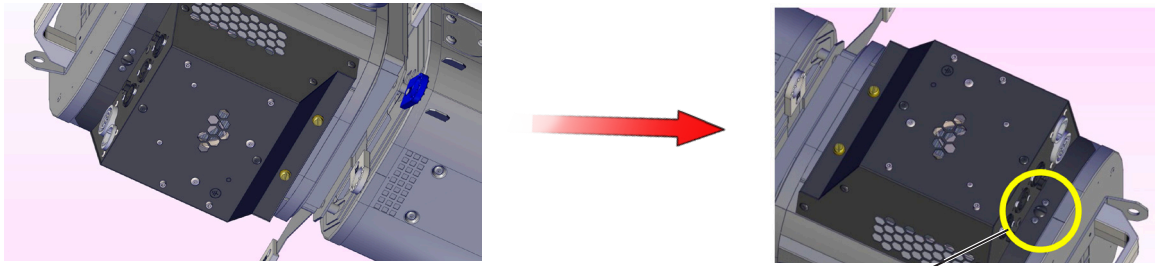

How to remove the Sully LED compartment for cleaning:

1. We recommend you place your luminaire on a flat clean surface. Disconnect from the mains before servicing.
2. Unlock the quarter turn screw with a flat screwdriver.
3. Remove the two screws with a flat screwdriver.
4. Slightly slide out the LED compartment and remove the earth attachment before removing it completely from its housing.
5. Carefully place the LED compartment on a flat clean surface.

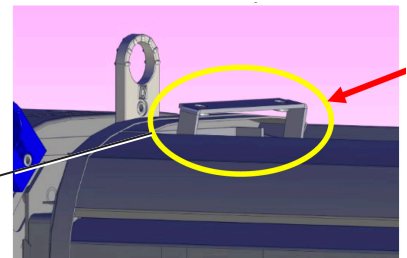
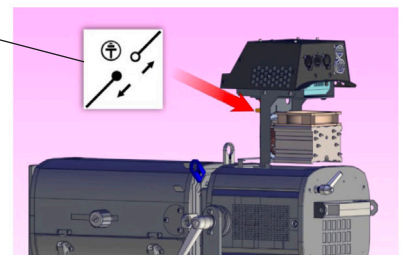
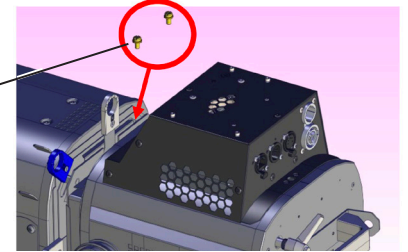

Sully LED compartment installation:

6. Extend the hinge to its maximum position to make it easily accessible. Insert the LED compartment into your luminaire, making sure it is positioned vertically to enable the LED compartment to enter the lamp house correctly.
7. Connect the ground connection (faston tab terminal) to the Sully LED compartment.
8. Once the LED compartment is fully inserted, remount tightly the two screws nearest the shutter gate. Re-tighten the quarter turn screw located at the back of the lamp base to lock the LED compartment securely into your luminaire.

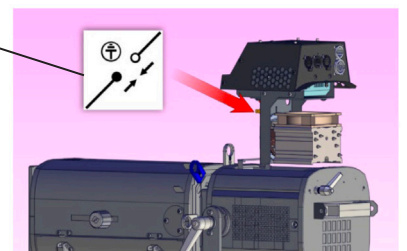

6.2 Analysis

In case of problem, contact RJ distributor with the following information:

- Model, version and serial number of the product.
- From the menu status:
 - Software version
 - LED board IDs
 - Device hours
- Description of the problem.



6.3 Electronic thermal management system

In case of overheating, light intensity will be reduced by the system.
Power reduction and temperature values are available by using a RDM protocol compatible device.

6.4 Firmware update



After updating your device with firmware V3.0, we strongly recommend that you update the source type (CCT) either to CW (Cold White) or WW (Warm White) by following the procedure described in the section below: **CCT selection**

CCT selection

Until now, the CCT of the LED source was not taken into account. From V3.0, your device will be automatically recognized as CW or WW source.

Devices shipped with firmware prior to V3.0 do not have a designated CCT.
After updating to V3.0, it is highly recommended to specify the CCT of your device.
For this you will have to stay on the Web Page that you used for the update.

In the **Source** section of the HOME tab, the CCT of your device is indicated.

- If "unknown", please select the CCT of your device and click on icon or , then on the arrow .

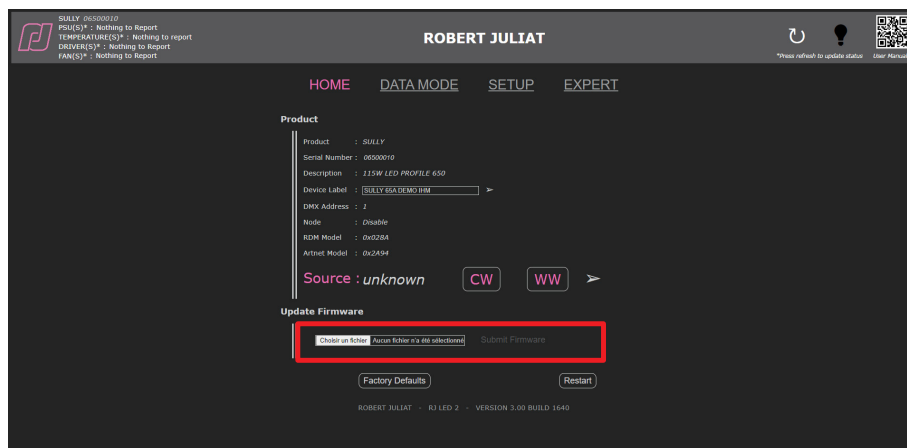

- Changing the source type changes the Model_ID as well. It is used in libraries to recognize devices automatically and for an Auto-Patch.
- If the source type has to be changed or in case of typing error, it will be always possible to change the source type in the Expert mode which is protected by a password.

1. Download the firmware from one of the following links :
 - www.robertjuliat.com/LED/PDF_PAGE or scan the QR code:
 - www.robertjuliat.com/followspots/SULLY_1156



2. Unzip the file. There are 4 files:
 - Firmware (.upd2 format)
 - Firmware history
 - Update procedure
 - User manual from firmware version V5.0x onwards

3. Switch on the lighting fixture.

4. Connect the fixture to the network using an RJ45 Ethernet cable from your computer.

You can either connect it to your lighting network (RJ45) or directly to your computer (RJ45).

5. Open a Web browser (Microsoft Edge, Firefox, Apple Safari, etc.).

6. Enter the fixture's IP address in the browser's address bar

- "00X" is read as "X".
- Never type a zero (0) before the numbers XX or X (see section 5.4).

7. Upload your firmware file (.upd2).

In the "Update firmware" window, select the update file and then click on "Submit firmware".

6.5 Factory defaults

6.5.1 Modes

Mode	Description
Restart	Software reset – all user parameters are kept
Factory defaults	Set all user parameters to factory default value

6.5.2 Control

Set to factory defaults / reset through web interface (Home page)

Set to factory defaults / reset through RDM protocol

Set to factory defaults / reset through local control, when equipped with this option

Select **FACTORY DEFAULT** in the main menu to reset all values and parameters

→ If IP address unknown (due to a previous modification), IP address can be read from RDM protocol or a hard reset must be done:

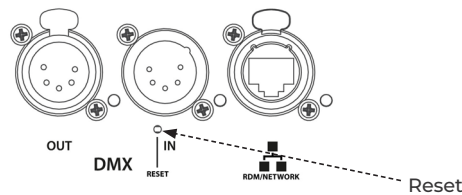

6.6 Selftest*

Select **SELFTEST** in the STATUS menu :

Press OK to start SELFTEST

STATUS

SELFTEST

SELFTEST SYSTEM ID DEVICE COU

At the end of each test, a **PASS/FAIL** message will be displayed.
If the DMX and network functions need to be tested, the system will prompt you to perform certain operations.

test report: Fail		P=Pass F=Fail	
fans P	pow P	temp P	dmxi P
dmxo F	net F	drv P	

Test Report

An “F” (FAIL) or “P” (PASS) will be displayed at the end of the self-test (SELFTEST).

If the problem persists, please take a photo of the test result and send it either to your Robert Juliat dealer or to the Robert Juliat After-Sales Service, if requested (email: service@robertjuliat.fr)

(*) if equipped with display and keyboard option

6.7 Testing for errors (LED unit without a display screen)

Testing and errors can be detected through RDM.

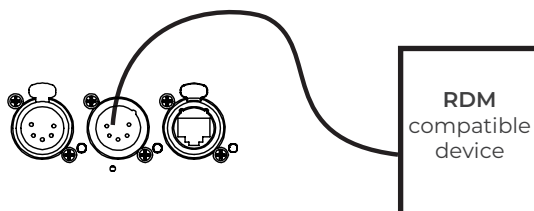

Test Report

Any FAILURE or ERRORS must be noted for feedback.

If the problem persists, please take a photo of the test result and send it either to your Robert Juliat dealer or to the Robert Juliat After-Sales Service, if requested (email: service@robertjuliat.fr)