

SULLY 1156

LED FOLLOWSPOT

Manual

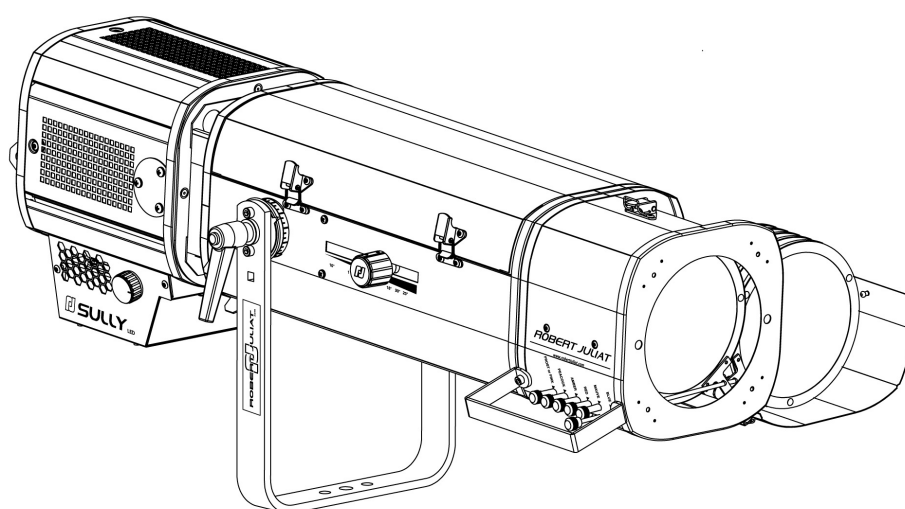

115 W FOLLOWSPOT

Model	Standard	North American
10.5° – 22.5° Warm White	1156WW	1156CWW
10.5° – 22.5° Cool White	1156CW	1156CCW

V1

- FIRMWARE: V4.0
- RJ-LED2 FIRMWARE PLATFORM (Node Mode) full manual is available for download at robertjuliat.com/LED/PDF_PAGE

VALIDATION : 18/06/24



ROBERT JULIAT

DN41202001 (EN)

Robert Juliat S.A.S. 32, rue de Beaumont, F 60530 Fresnoy-en-Thelle - phone : +33 (0)3 44 26 51 89 - info@robertjuliat.fr

www.robertjuliat.com

Table of Contents

1	User's instructions	1	5	Controls and parameters	20
2	Presentation	2	5.1	Local display and controls	20
2.1	Functions	2	5.1.1	Display	20
2.2	Identification labels	2	5.1.2	Menu	21
2.2.1	Label on LED compartment	2	5.1.3	Parameters	22
2.2.2	Label on lighting unit	3	5.2	DMX512 - A remote control	23
2.3	Accessories included	3	5.2.1	Protocol	23
2.4	Accessories	4	5.2.2	Configuration	23
3	Set-up	5	5.2.3	Parameters	24
3.1	Mechanics	5	5.2.3.1	DMX Hold	24
3.1.1	Operating positions	5	5.2.4	DMX chart	25
3.1.2	Minimum distance between a flammable material and the lighting unit	5	5.2.5	DMX ranges	25
3.1.3	Instructions for use	5	5.2.5.1	Strobe duration	25
3.1.4	Lifting	5	5.2.5.2	Strobe speed	25
3.1.5	Stand set-up	6	5.2.5.3	Response time	25
3.2	Electrical information	6	5.2.5.4	Control mode	25
3.2.1	LED source	6	5.3	RDM remote control	26
3.2.2	Power supply	6	5.3.1	Protocol	26
3.3	DATA	7	5.3.2	Configuration	26
3.3.1	DMX 512-A / RDM	7	5.4	Art-Net remote control	28
3.3.2	Art-Net / sACN	8	5.4.1	Protocol	28
3.3.3	Ethernet / DMX node	8	5.4.2	Configuration	28
3.4	Accessories	9	5.4.3	Local set-up	29
3.4.1	Iris	9	5.5	sACN remote control	30
3.4.2	Gobo holder	9	5.5.1	Protocol	30
3.4.3	Internal filter holder	10	5.5.2	Configuration	30
3.4.4	Colour changer unit - push-pull	10	5.5.3	Local set-up	31
3.4.5	Double slot front cassette for front accessories (option)	11	5.6	Dual remote control	32
3.4.6	Double-condenser set	12	5.6.1	Protocol	32
4	Operations	13	5.6.2	Configuration	32
4.1	Light intensity	13	5.6.3	Local set-up	33
4.1.1	Range	13	5.7	Web interface	34
4.1.2	Control	13	5.7.1	Control	34
4.1.3	Parameters	13	5.7.2	Default IP address	34
4.1.3.1	Dimming resolution - DMX only	13	5.7.3	Network IP of the computer	34
4.1.3.2	Dimming curve	14	5.7.4	Connect to web interface	34
4.1.3.3	Master control	14	5.7.5	CCT selection	35
4.1.3.4	Set maximum position	14	5.8	LEDs Feedback	36
4.1.3.5	Dimming mode	15	5.8.1	Trouble shooting	36
4.2	Strobe	15	5.8.2	Parameters	36
4.2.1	Range	15	5.8.2.1	Intensity	36
4.2.2	Control	15	5.8.2.2	Auto-OFF	36
4.3	Response time	15	6	Service	37
4.3.1	Range	15	6.1	Preventive maintenance	37
4.3.2	Control	16	6.1.1	Frequency	37
4.4	Beam size adjustment	16	6.1.2	General cleaning	37
4.4.1	Range	16	6.1.3	General visual check	37
4.4.2	Control	16	6.1.4	LED source	37
4.5	Orientation	17	6.1.5	Optics	37
4.5.1	Range	17	6.1.6	LED house cleaning	37
4.5.2	Control	17	6.2	Analysis	38
4.6	Iris	18	6.3	Electronic thermal management system	39
4.6.1	Range	18	6.4	Firmware update	39
4.6.2	Control	18	6.5	Factory defaults	40
4.7	Gobo	18	6.5.1	Modes	40
4.7.1	Range	18	6.5.2	Control	40
4.8	Colour	18	6.6	Selftest	41
4.8.1	Range	18			

GENERAL INSTRUCTIONS

1. Not for residential use.
2. These fixtures must only be serviced by a qualified technician.
3. In addition to the instructions indicated on this page, relevant health and safety requirements of the appropriate EU Directives must be adhered to at all times.
4. This fixture is in compliance with section 17 - Lighting appliance for theatre stages, television, cinema and photograph studios. Standards NF EN 60598-1, NF EN 60598-2-17, Low Voltage Directive 2014/35/UE & EMC Directive 2014/30/UE.
5. This fixture is rated as IP20, and is for indoor use only.

FIXTURE

6. Ensure fixture is correctly mounted on an appropriate support.
7. Protection screens and lenses must be replaced in the event of any damage, such as cracks or deep scratches, since these might reduce performance.
8. When hung or flown the fixture must be secured by an additional hanging accessory (such as a safety cable or bond) of suitable length.
9. Safety bonds or cables must be securely attached to the back of the fixture and be as short as possible, or rolled up as necessary, to minimise travel distance should the fixture be dislodged.
10. Movable accessories (scroller, etc.) must also be secured with a suitable safety cable or bond at the front of the fixture.
11. The combined weight of both the fixture and the accessories must be considered when choosing the load-bearing capability of safety cable or bond.
12. Do not open lighting fixture when the source is on.
13. WARNING: LED source become hot during use. Allow fixture to cool before servicing.
14. Do not tamper with design of fixture nor any of its safety features.
15. Tighten electrical mains cable connections regularly and replace with one of identical specification if damaged.
16. Use only with correct power supply.

VENTILATION

17. Keep well away from flammable material.
18. Not for outdoor use. Do not cover. Do not permit fixture to get wet.
19. To avoid overheating, do not obstruct air vents.
20. Ensure any cooling fans are in correct working order. If fans are not working, turn fixture off immediately and service as necessary.

CLEANING

21. Do not touch the LED source with your fingers.
22. To clean the optical parts, use a soft cloth in combination with distilled water or isopropyl alcohol recommended for coated optics. Do not use any cleaning product that contains solvents or abrasives, as these can cause surface damage. Dry with a soft lint-free cloth.
23. Regularly remove dust with a soft lint-free cloth.
24. If the fixture has filters, they must be cleaned frequently.

POWER SUPPLY

25. Disconnect from the mains before servicing.
26. Mains connection only. Do not connect to "electronic output" such as dimmer.
27. Ensure power supply circuit breakers, always remain accessible.

PLEASE NOTE

This product has been built to conform to European standards relating to professional lighting equipment. Any modification made to our products will void the manufacturers' warranty.

Photobiological safety according to EN62471

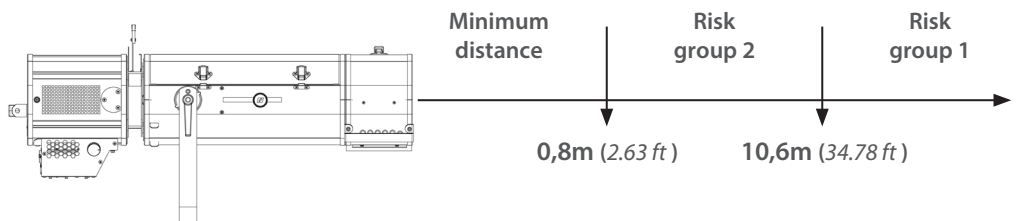

Risk group 2



CAUTION: Possibly hazardous optical radiation emitted from this product. Do not stare at operating lamp. Maybe harmful to the eye.

Group risk 2. Luminaires should be positioned so that prolonged staring into luminaire at a distance closer than 10,6m is not expected.

Description

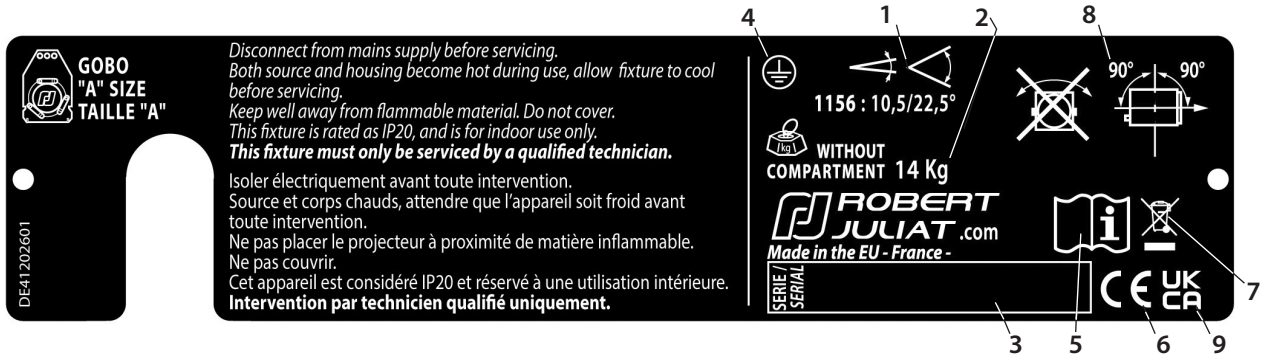

1. Model beam angles
2. Net weight (kg) without LED compartment
3. Serial number
4. Class 1 product label
5. Read manual first label
6. European conformity label
7. WEEE directive label
8. Operating positions
9. UKCA (UK Conformity Assessed) label

Units :
 - Weight = kilogram (kg).
 - Intensity = Ampere (A).
 - Voltage = Volt (V).
 - Frequency = Hertz (Hz).
 - Temperature = degree Celsius (°C).

2.3 Accessories included

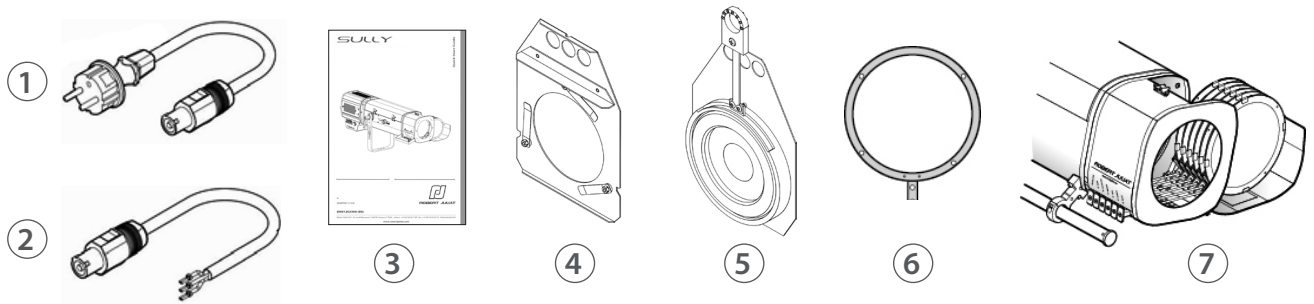

	Reference	Description
1	CAL03	Power cable with CEE 7/7 type in connectors (standard version)
2	CAL04	UL/CSA power cable without connector (North-American version)
3	DN41202400	Quick Start manual
4	SGUX	Universal "A" size gobo holder (metal, glass or frosted glass)
5	IS750	Full closing iris with holder
6	PF1114	Ø165 mm metal filter holder (x6)
7	M165TP	6-way "push/pull" colour changer

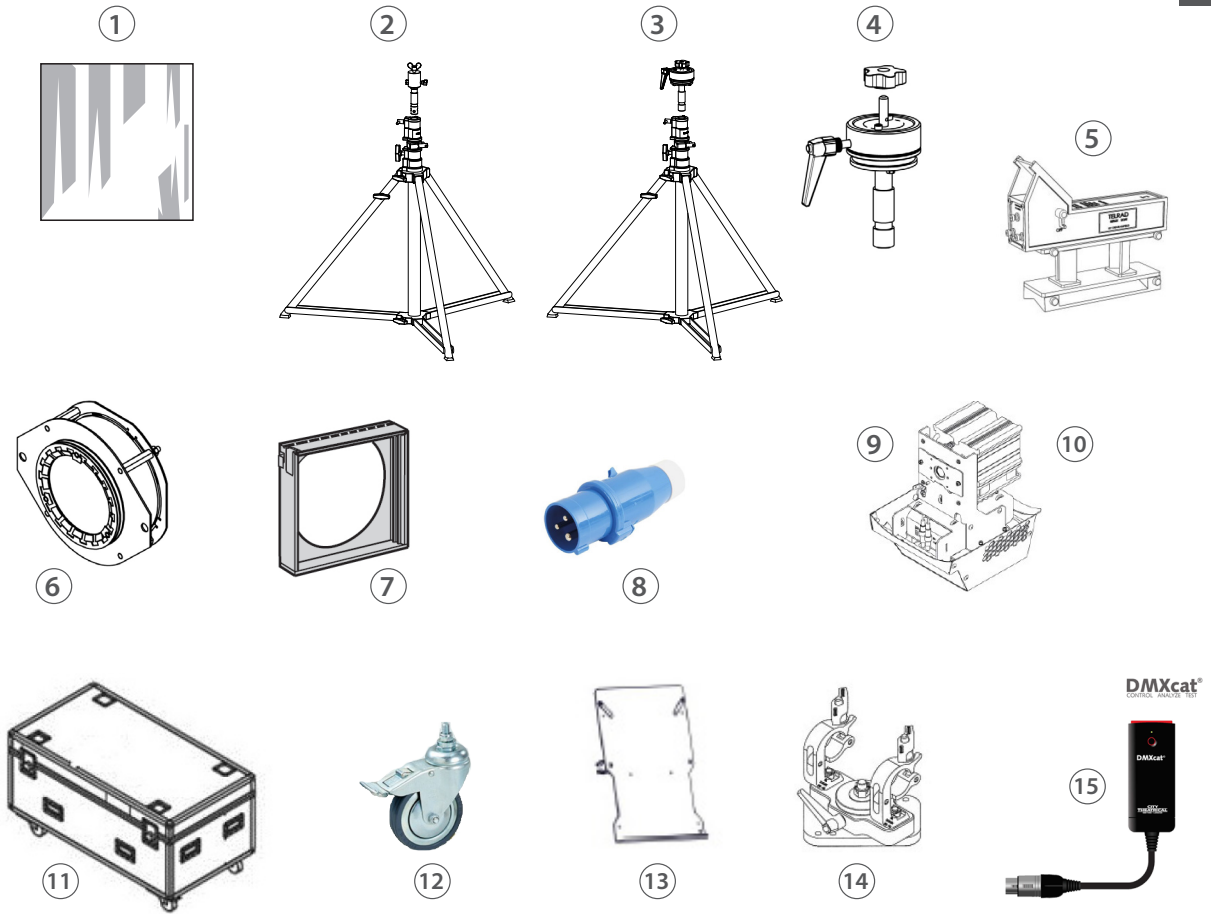

	Reference	Description
1	VD120	120 x 120 mm frosted glass
2	GT800	Tripod stand GT800 - SWL: 40 kg max. height 1550 mm
3	GT1000	Tripod stand GT1000 - SWL: 40 kg max. height 1550 mm
4	T1000	TV spigot with followspots swivel head
5	Kit TELRAD	Followspot sight with riser
6	APH 68LED	Double-condenser set for Led profile
7	CAV600A	Double slot front cassette for 180x180mm accessories
8	PCP1716A	16A blue 2P+E 6h IEC60309 power connector
9	T/1650SXCW	SULLY 115W LED compartment with potentiometer - Cool White - 3 meter power cable with CEE 7/7 (2P+T NF/SCHUKO) connector
10	T/1650SXWW	SULLY 115W LED compartment with potentiometer - Warm White - 3 meter power cable with CEE 7/7 (2P+T NF/SCHUKO) connector
11	FC1124/S	Transport flight-case for ultra compact range followspots
12	W/GT800	Set of 3 wheels for GT800/1000 stands
13	SDUP	Followspot cue sheet holder with universal mounting kit
14	T4000	Followspot mount for Ø50 mm pipe (suspension or overhead) - SWL= 100 Kg
15	DMXcat	Bluetooth DMX/RDM Multifunction test tool - City Theatrical DMXcat®

3.1 Mechanics

3.1.1 Operating positions

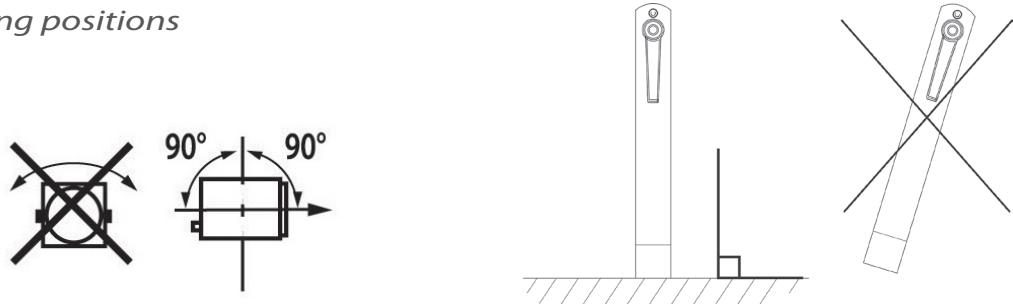

3.1.2 Minimum distance between a flammable material and the lighting unit

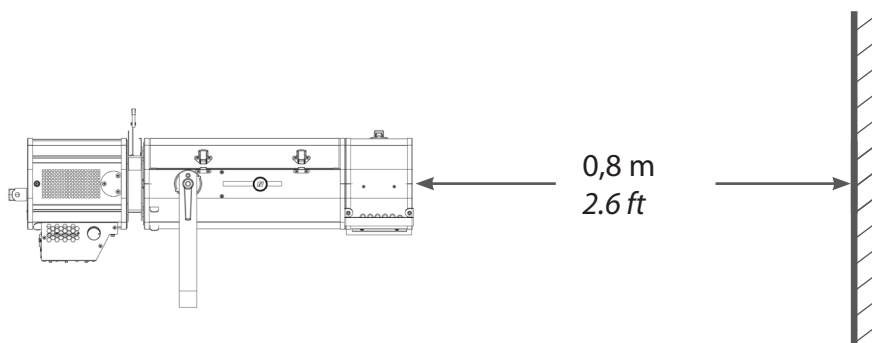

3.1.3 Instructions for use

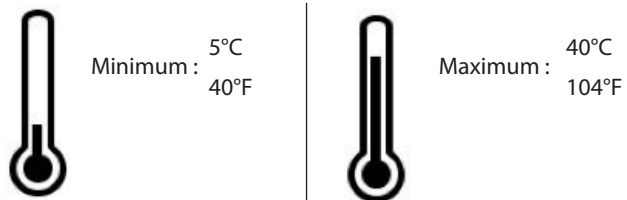

IP20 - Indoor use only

3.1.4 Lifting

- Net weight: 15.6 Kg (34,3 lbs).

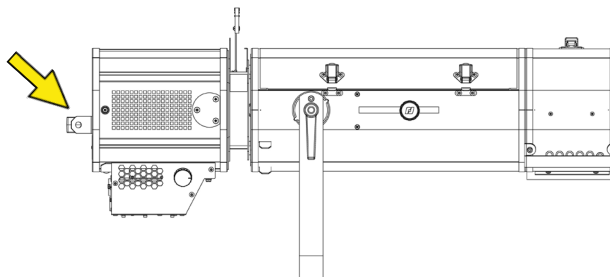

3.1.5 Stand set-up

- Compatible stands : GT800 & GT1000
Please refer to the relevant user manual for further details.

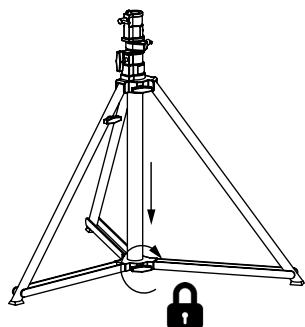

↓ MAX
40kgs/88lbs

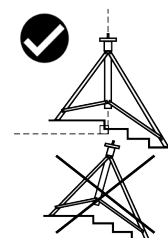
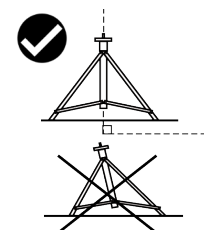
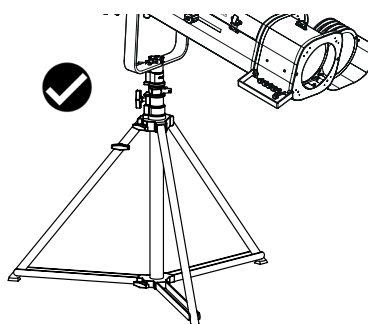

3.2 Electrical information

3.2.1 LED source



Never touch or scratch the LED surface.
See 6.1.4 LED cleaning procedure if cleaning is necessary.

3.2.2 Power supply

Power supply			
Voltage	Frequency	Input power	Connectors
100 → 264 V	50-60 Hz	0,7 A / 130 W @ 230V 1,15 A / 135 W @ 120V 1,40 A / 135 W @ 100V Max: 1,5A Standby mode: 10W	Neutrik powerCON TRUE1 TOP Input : ref. NAC3FPX-TOP



- Class 1 product. **This luminaire must be earthed.**
- Must be connected directly to AC power. **Do not connect to dimmer power.**
- Automatic mains voltage detection.

Daisy chain (with delivered power cable):

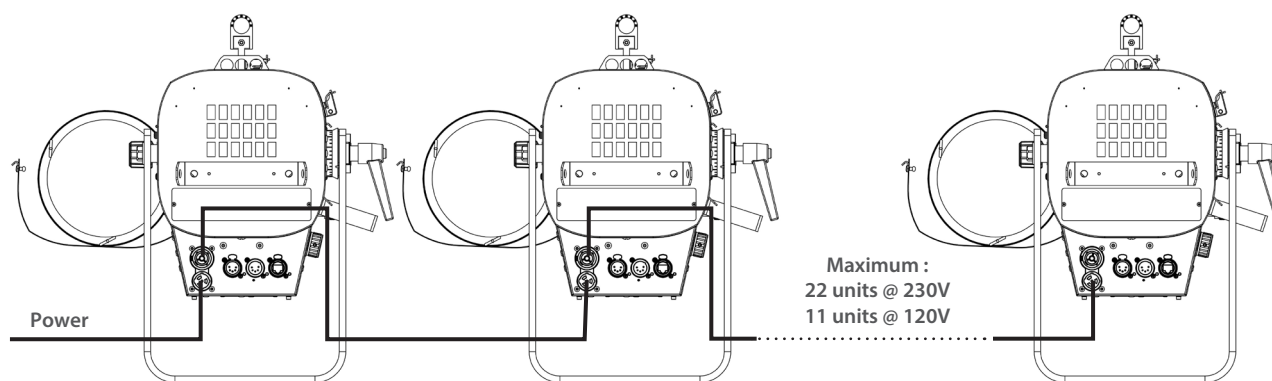

Power cable

Power cable		Connector	Mains plug	Cable type	Cable length	Wiring
1	Standard version	Neutrik® powerCON TRUE1 TOP NAC3FX-W-TOP	CEE7/7	3G1.5 H07RNF	3 m 9.8 ft	Live: Brown Neutral: Blue Ground: Yellow/Green
2	North American version		-	14AWG SJ TYPE (UL/CSA)	1.5 m 4.9 ft	Live: Black Neutral: White Ground: Green

3.3 DATA

3.3.1 DMX 512-A / RDM

Protocol		Input connector	Output connector
USITT DMX 512-A RDM		XLR 5-pin	XLR 5-pin

DATA connectors			
PIN #	DMX	Description	
1	Shielding	Foil & Braided Shield	<p style="text-align: center;">DMX OUT DMX IN</p>
2	DMX (-)	1 st conductor of 1 st twisted pair	
3	DMX (+)	2 nd conductor of 1 st twisted pair	
4	Not used	1 st conductor of 2 nd twisted pair	
5	Not used	2 nd conductor of 2 nd twisted pair	

Daisy chain:

Maximum :
31 units total

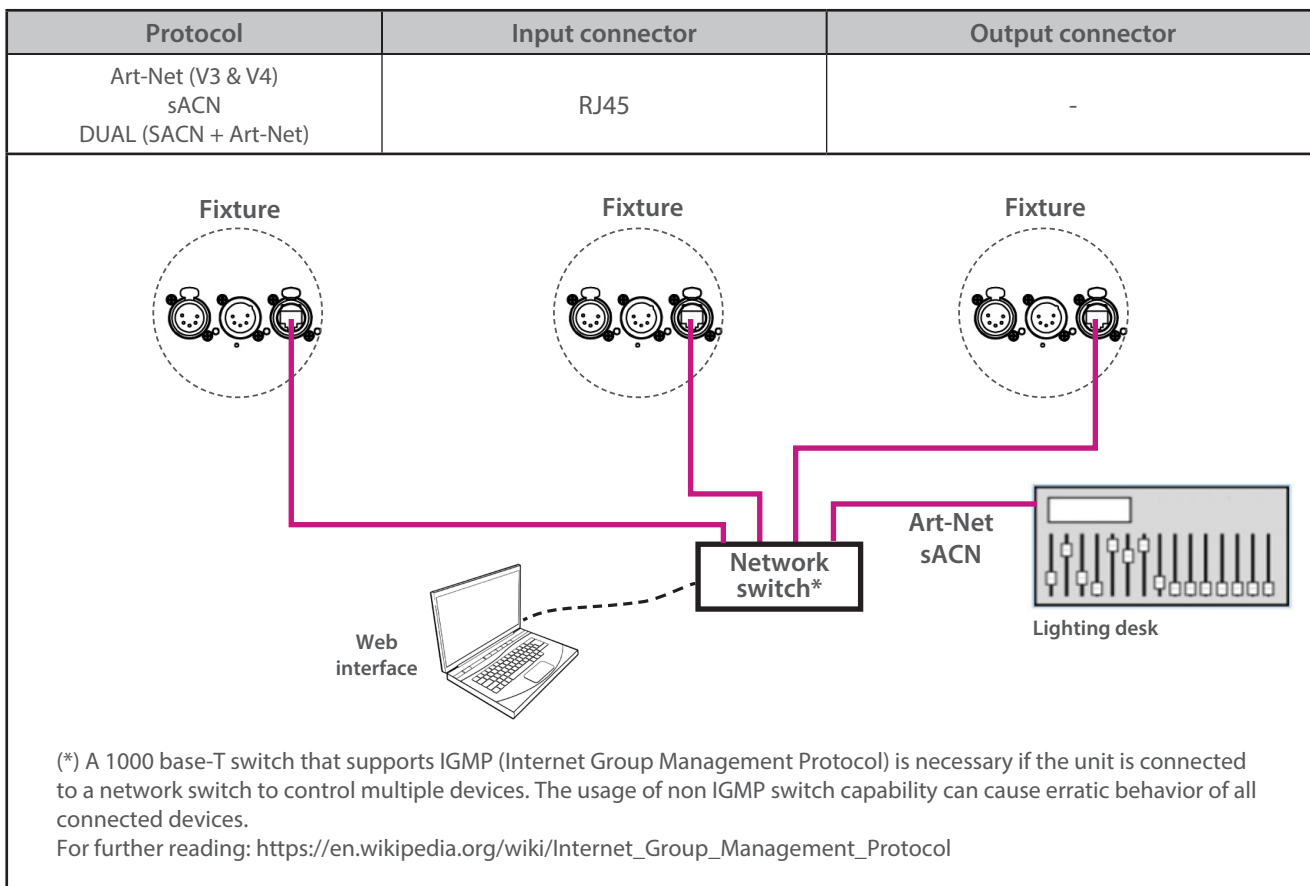

3.3.3 Ethernet / DMX node

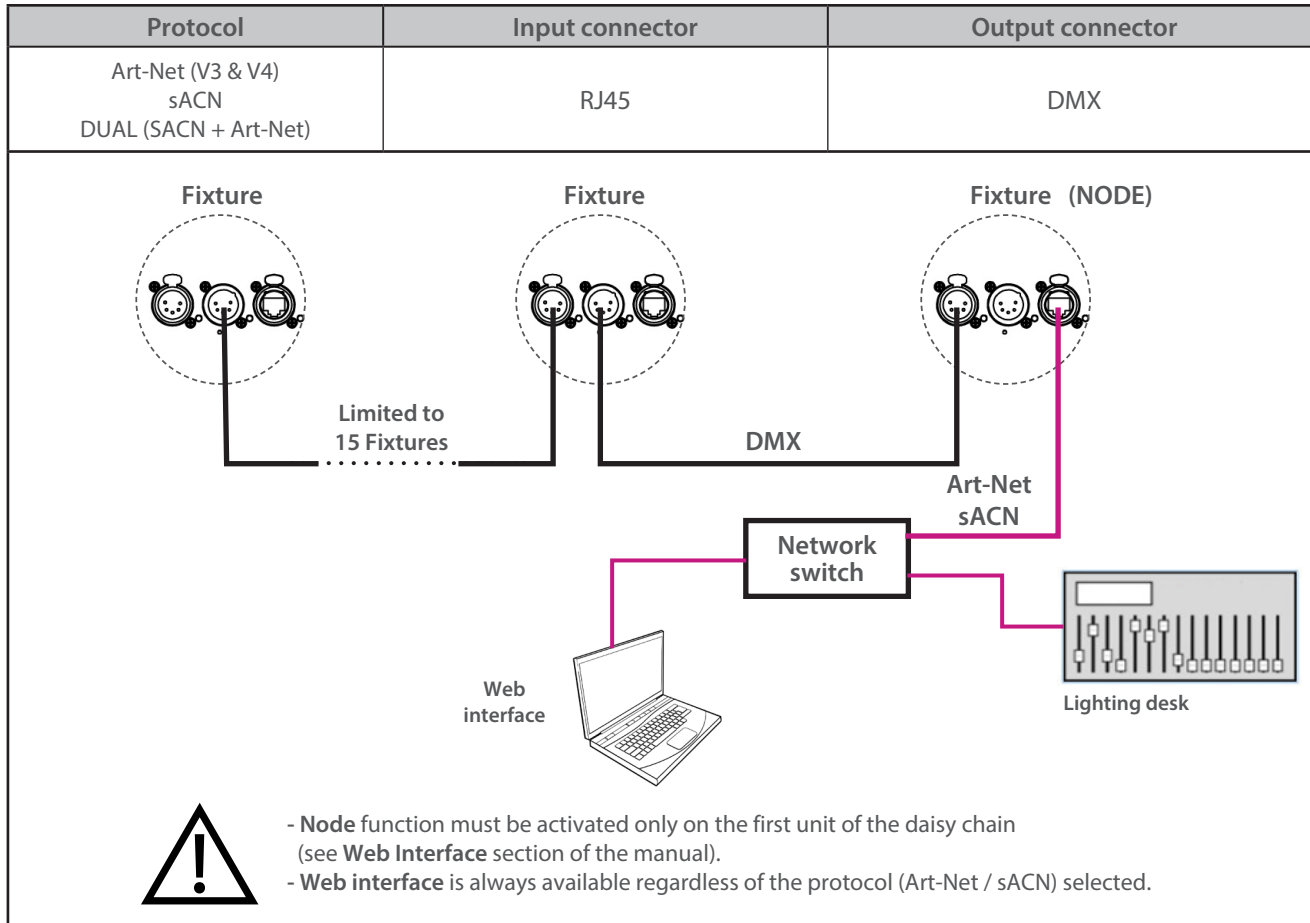

RJ-LED2 FIRMWARE PLATFORM (Node Mode) full manual is available for download at robertjuliat.com/LED/PDF_PAGE

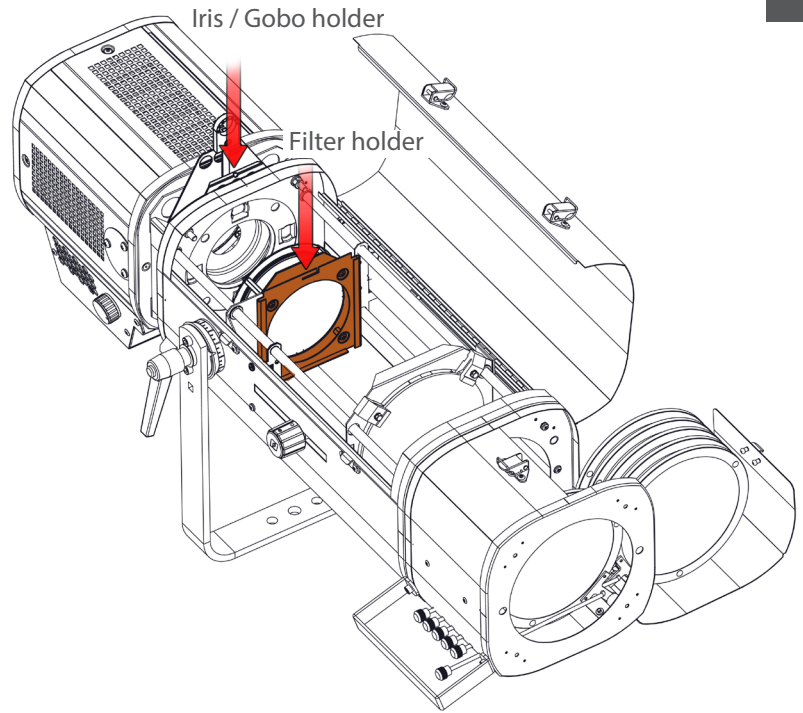

3.4.1 Iris

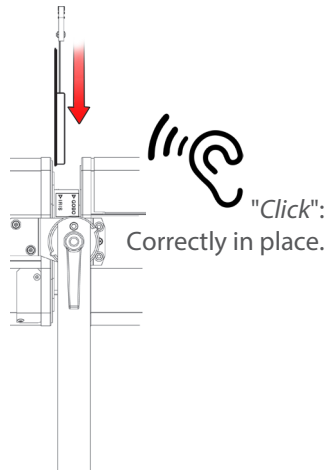
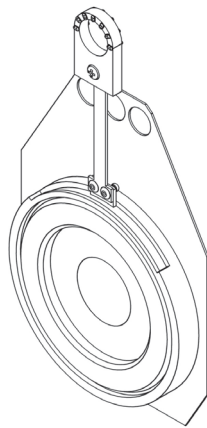

3.4.2 Gobo holder

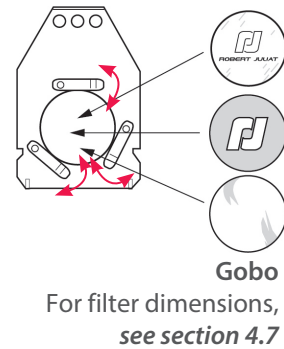
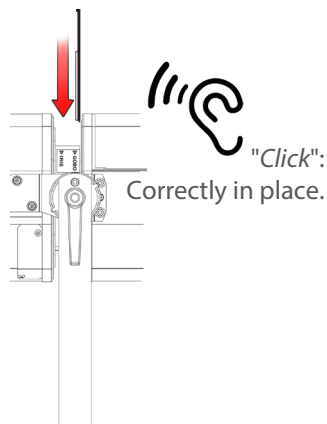
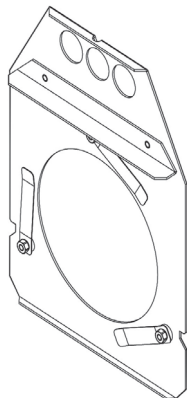

3.4.3 Internal filter holder

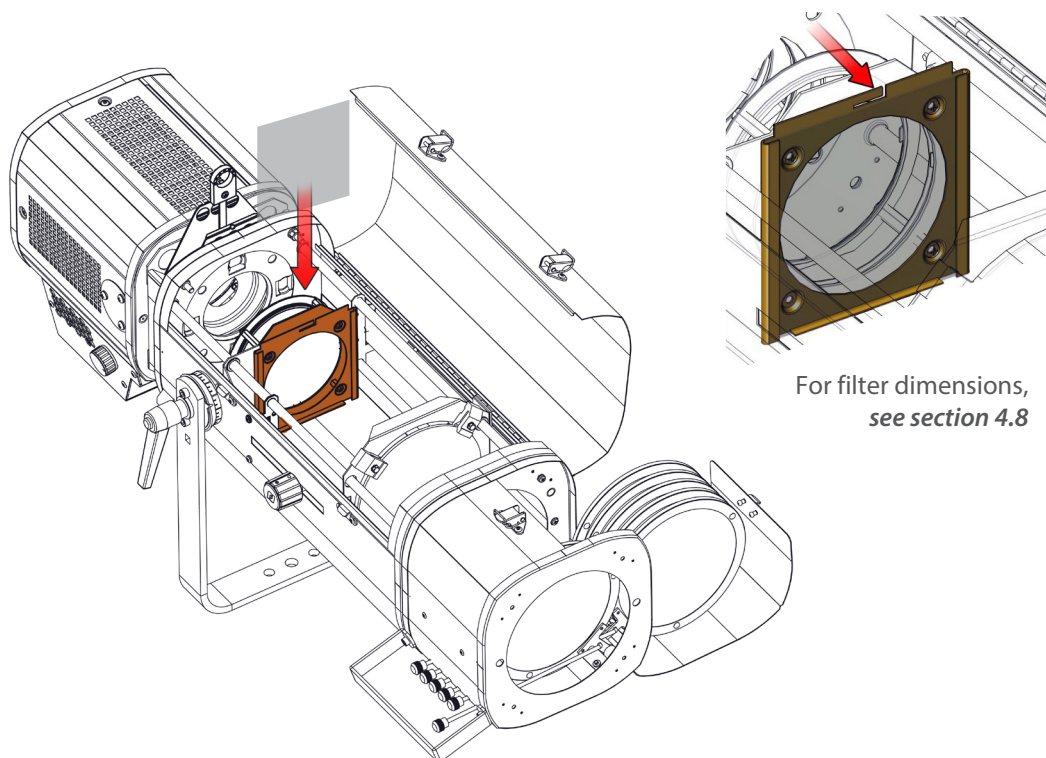

For filter dimensions,
see section 4.8

3.4.4 Colour changer unit - push-pull

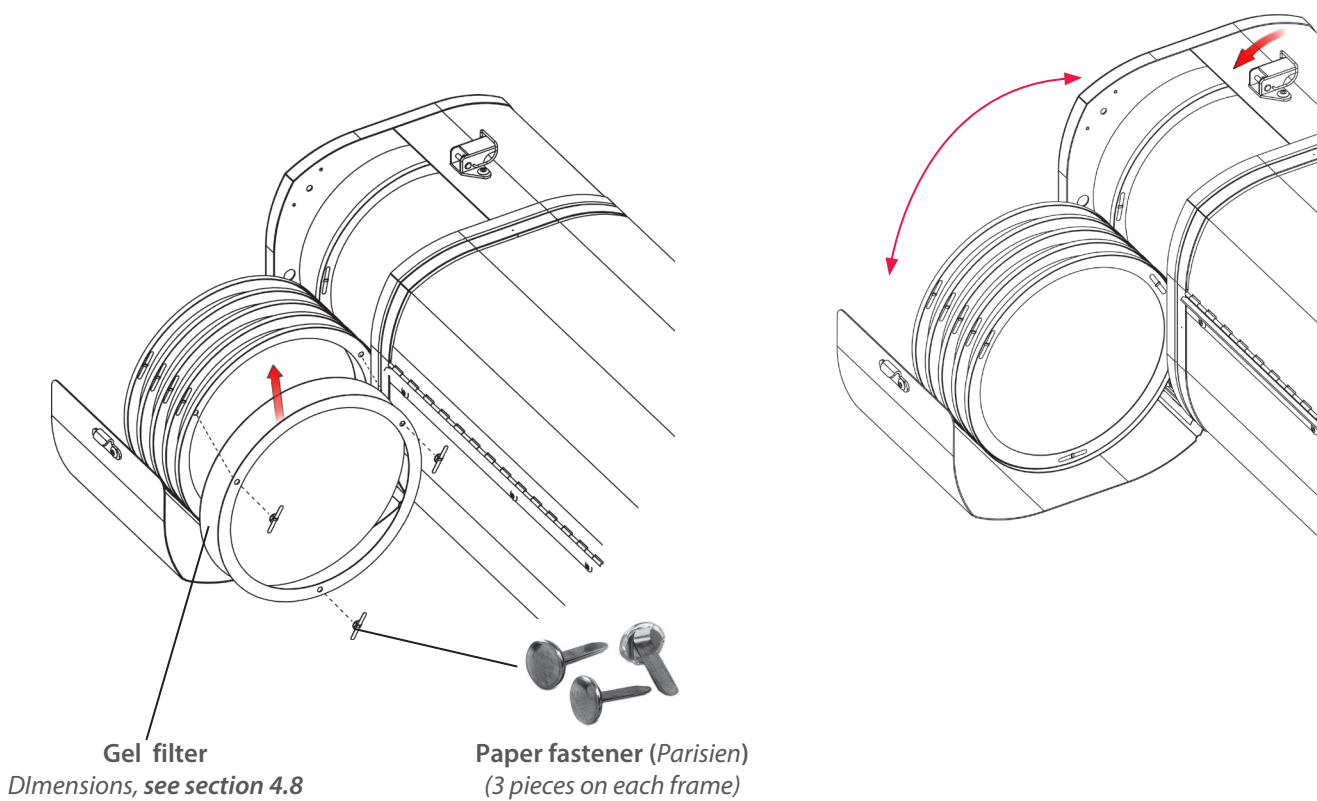

3.4.5 Double slot front cassette for front accessories (option)

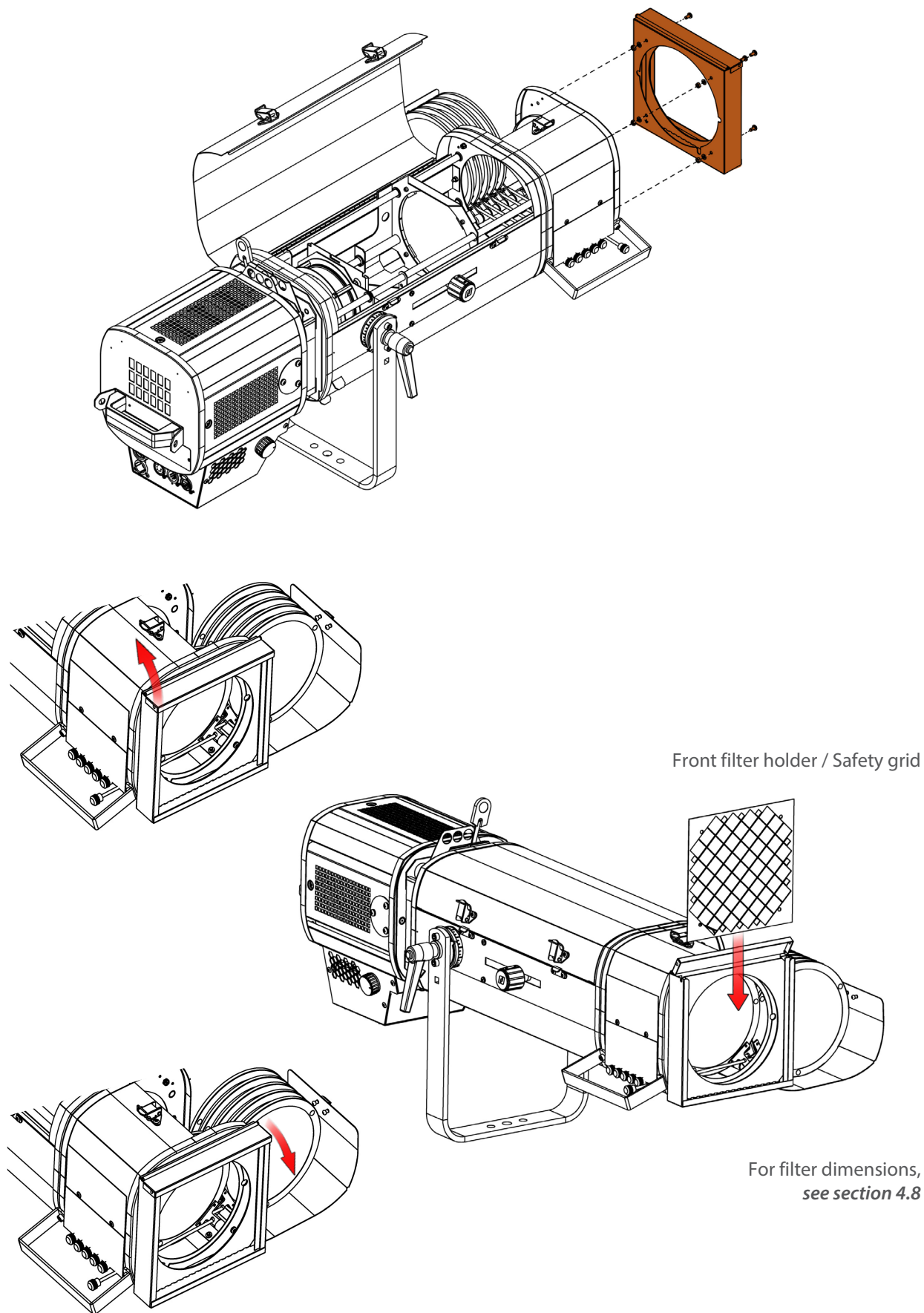

3.4.6 Double-condenser set

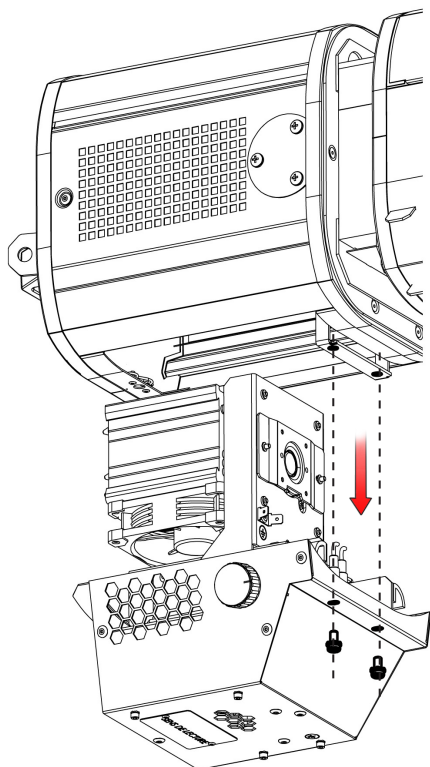

For full procedure,
see page EN-38

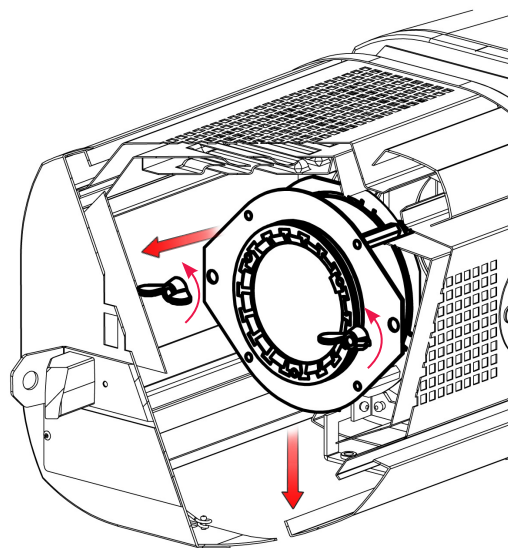

APH68 LED only possible with LED version
(not with halogen).

4.1 Light intensity

4.1.1 Range



4.1.2 Control

Remotely with DMX512-A / Art-Net / sACN protocols.

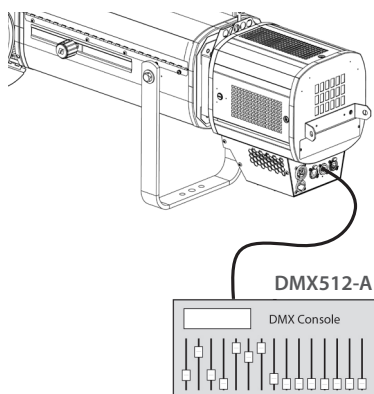

→ Set through RDM protocol or web interface

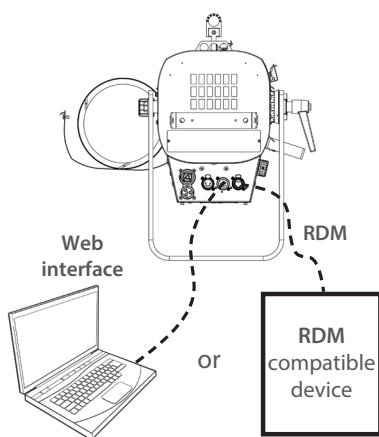

Locally via rotary knob

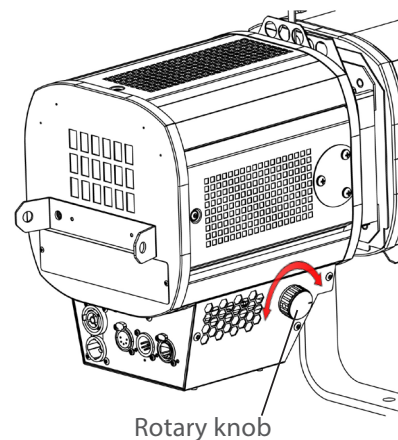

HTP mode (Highest Takes Precedence):
Light output is the highest value of DMX512 command or local control

4.1.3 Parameters

4.1.3.1 Dimming resolution - DMX only

→ Set through RDM protocol or web interface

Resolution	DMX mode
8 bits – 255 steps	1 - 3
16 bits – 65 535 steps	2 - 4

➔ Set through RDM protocol or web interface

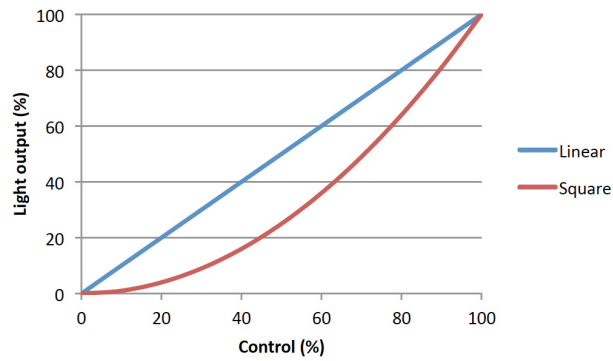

4.1.3.3 Master control

In order to supervise the operator from the console, master control DMX channel can be used. This channel limits the maximum value of the dimmer shutter. By using this function, it is possible to obtain synchronised fades with several spots or to give intensity limits (minimum and maximum) to the operator. Master is only active when DMX is detected.

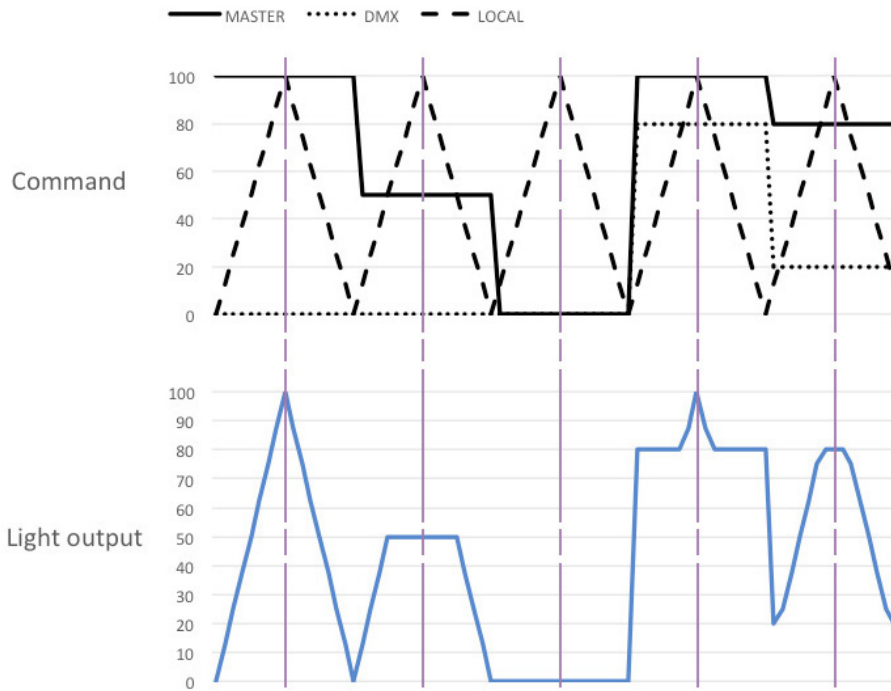

4.1.3.4 Set maximum position

➔ Set through RDM protocol or web interface

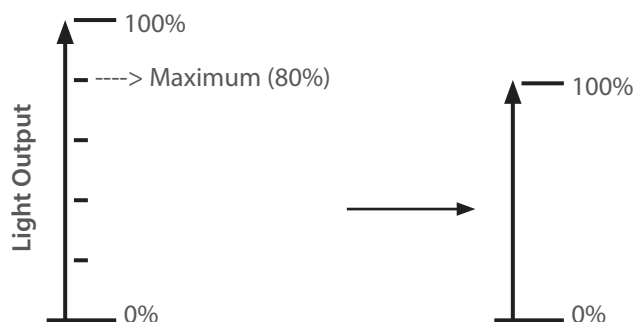

→ Set through RDM protocol or web interface

Mode	Result
Without PWM	Flicker-Free, perfect for filming
PWM 17 kHz	Good dimming quality (Default Value)
PWM 3,2 kHz	Very good dimming

4.2 Strobe

4.2.1 Range

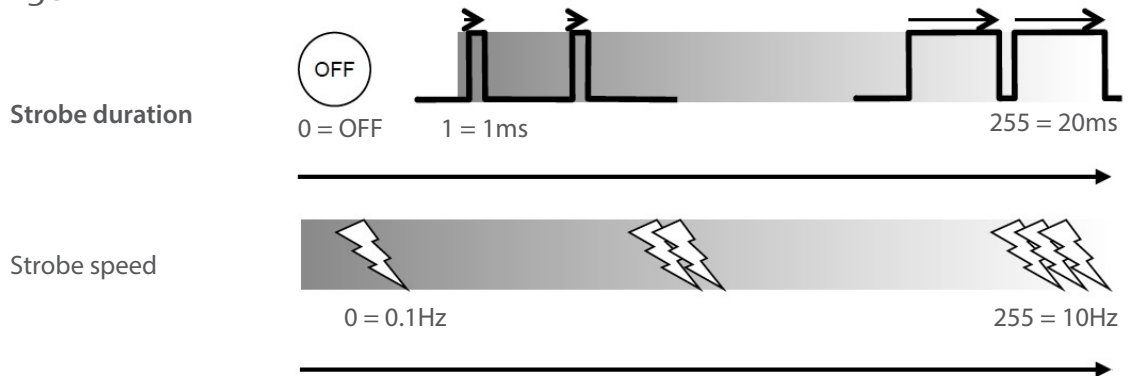

4.2.2 Control

→ Remotely with DMX512-A / Art-Net / sACN protocols.
Mode 3 – 4

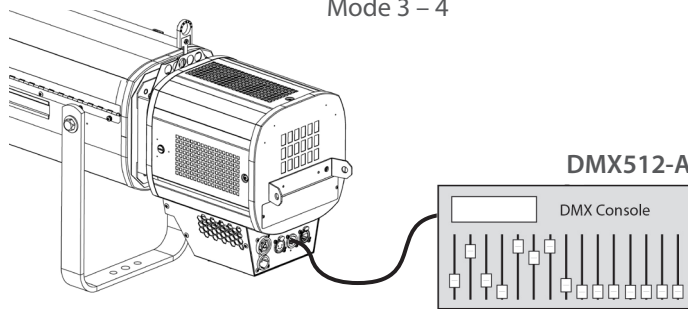

4.3 Response time

4.3.1 Range

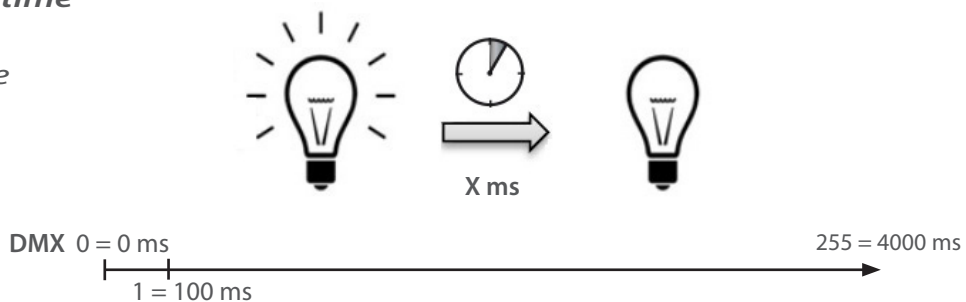

4.3.2 Control

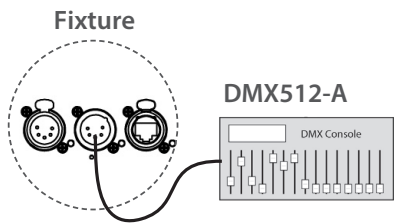

Remotely, with DMX512-A / Art-Net / sACN protocols Mode 3 – 4 only

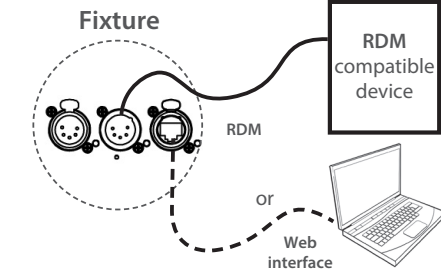

→ Set through RDM protocol or web interface

Mode	Speed
NONE	OFF
SLOW	700 ms
MEDIUM	470 ms
FAST	350 ms
CUSTOM	0 - 4000 ms

Locally, when equipped with this option

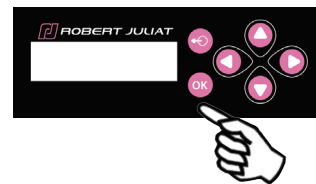

Only when no DMX detected :
→ selection in SETUP/DIMMER/
RESPONSE TIME

Mode	Speed
NONE	OFF
SLOW	700 ms
MEDIUM	470 ms
FAST	350 ms
CUSTOM	0 - 4000 ms

4.4 Beam size adjustment

4.4.1 Range

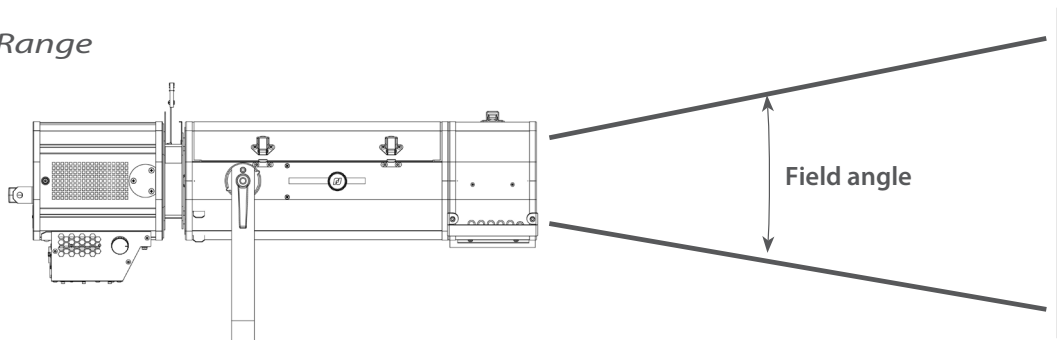

Model	Minimum angle	Maximum angle
1156	10.5°	22.5°

4.4.2 Control

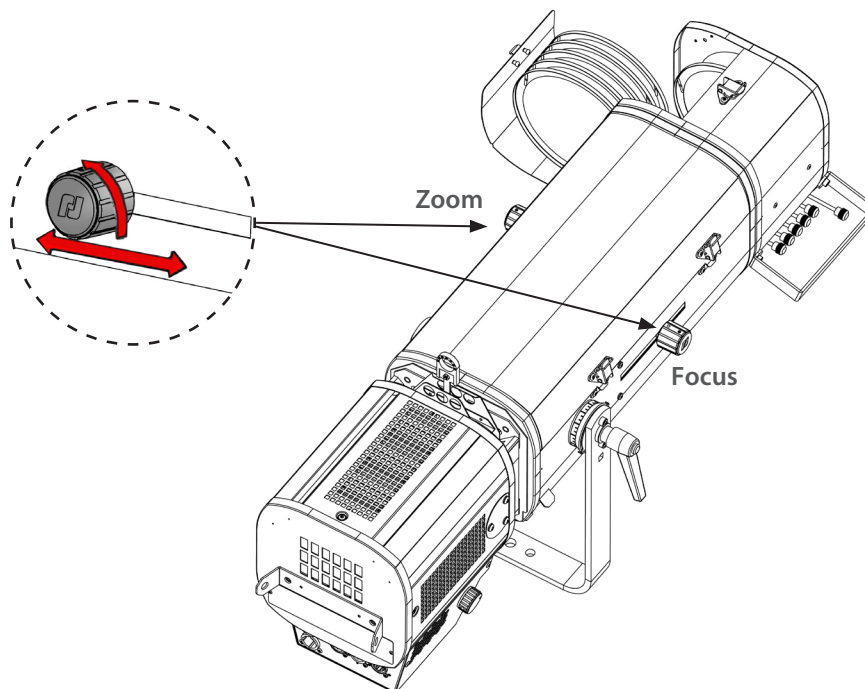

4.5 Orientation

4.5.1 Range

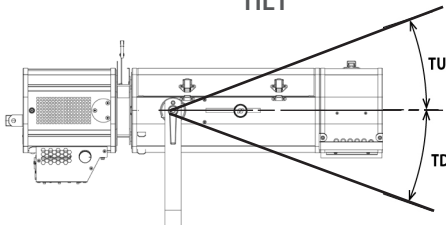
Function	Range
PAN	0 → 360°
TILT	 TU = 0 → 38° TD = 0 → 56°

4.5.2 Control

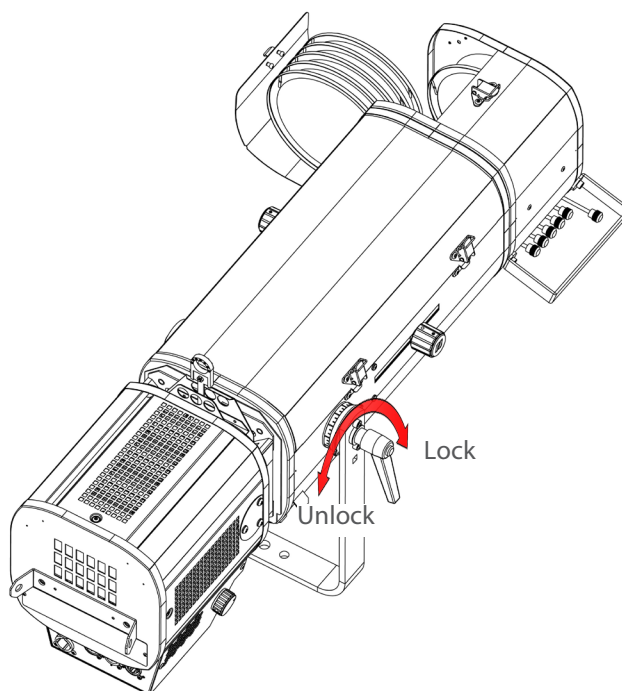

4.6 Iris

4.6.1 Range

- *Irising*

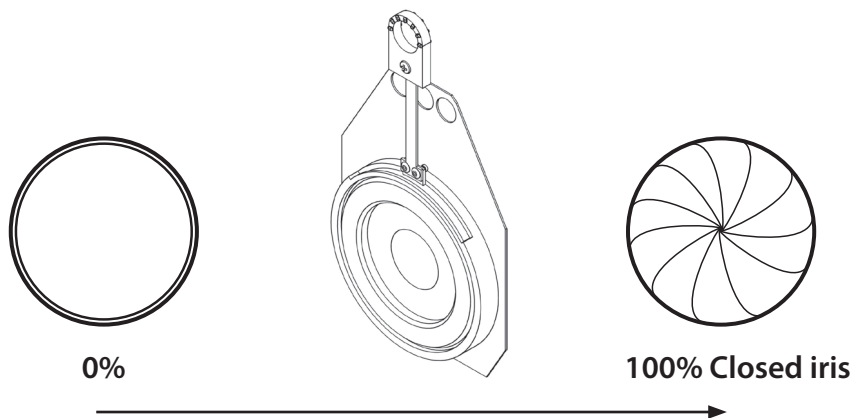

4.6.2 Control

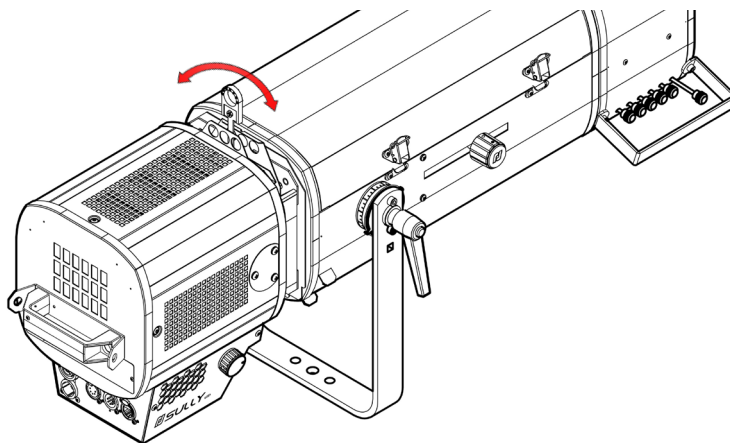

4.7 Gobo

4.7.1 Range

Type	Standard gobo - A size	
Dimensions		<p>100 mm</p> <ul style="list-style-type: none"> • Metal • Glass <p><i>Values are in millimeters (mm)</i></p>
Installation	See 3.4.3	

4.8 Colour

- Fixed colour: place dark colours towards the rear end.

4.8.1 Range

Type	Coloured gel filter
Dimension	<p>165 mm</p>
Installation	See 3.4.4

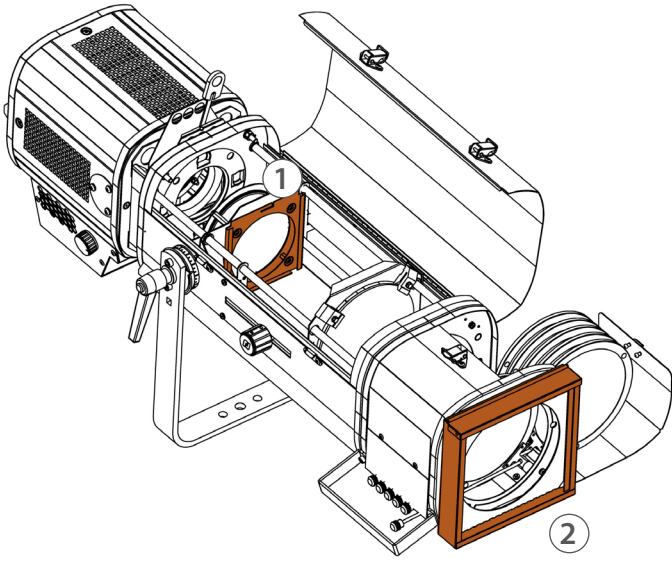
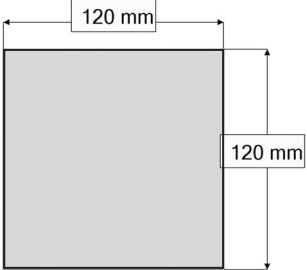
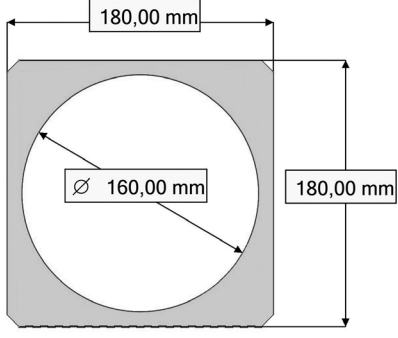
<p>Location</p>		
	<p>1. Internal filter holder</p>	<p>2. Front filter cassette (option)</p>
<p>Type</p>	<p>Frosted or dichroic glass</p>	<p>Coloured gel filter (option)</p>
<p>Dimensions</p>		
<p>Installation</p>	<p>See 3.4.3</p>	<p>See 3.4.5</p>

5.1 Local display and controls*

5.1.1 Display

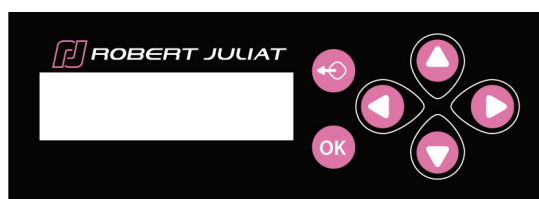

Function	
	Exit the current menu option and/or go back
	Enter the current menu option and/or valid
	Scroll through menus and/or Increase data value
	Scroll through menus and/or Decrease data value
	Menu down and/or Increase data value
	Menu up and/or Decrease data value

(*) If equipped with this option

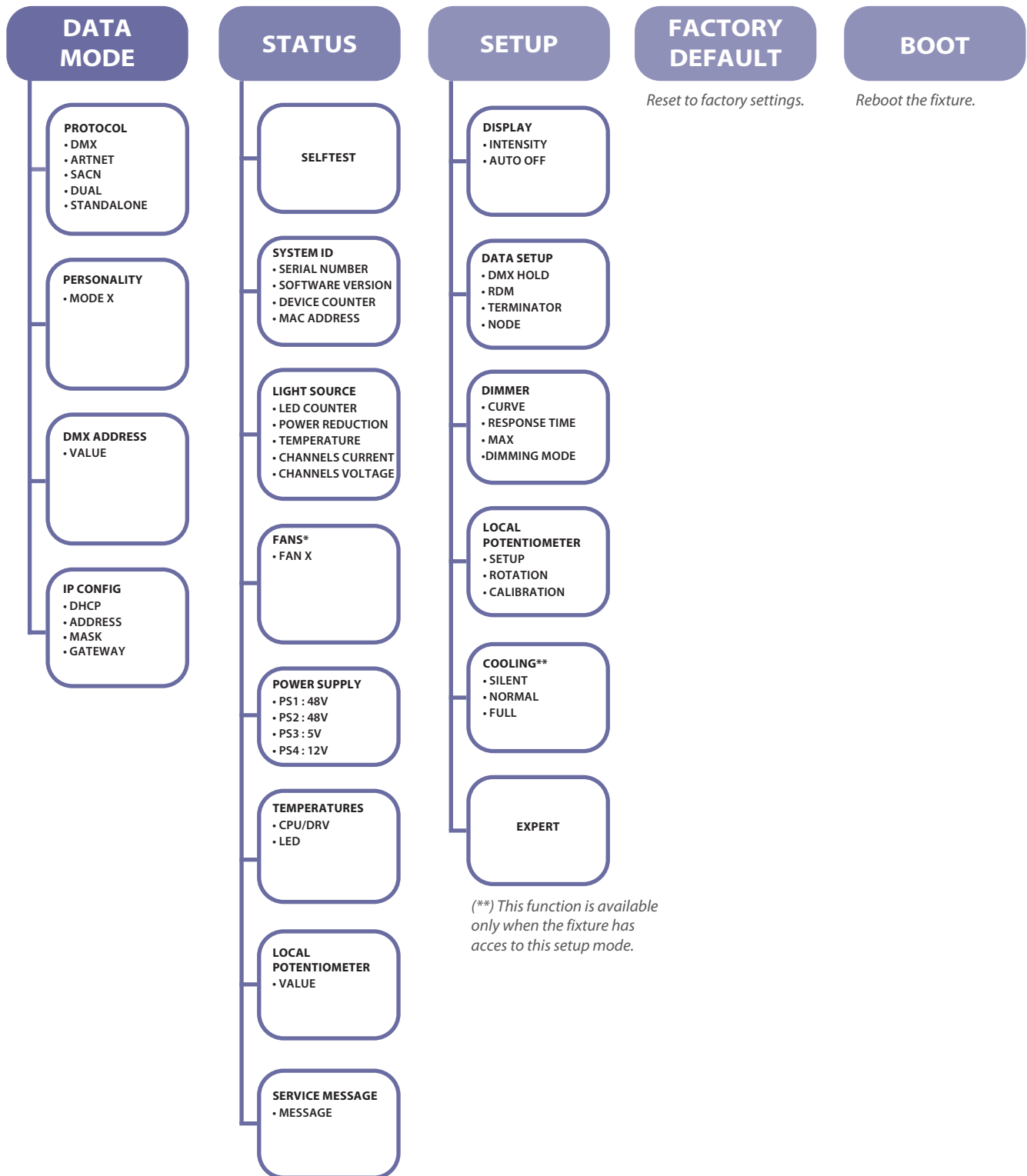

(*) The number of fans may vary depending on the fixture.

(**) This function is available only when the fixture has acces to this setup mode.

→ Selection in *SETUP/DISPLAY MODE* menu

Display	Mode	Description
	Always ON	Main display (home screen) always ON
	Intensity	Adjust the intensity of the screen To change value, press buttons : press OK to validate
	Auto-OFF	Main display OFF after 20 seconds

5.2.1 Protocol

E1.11 – 2008, USITT DMX512-A

5.2.2 Configuration

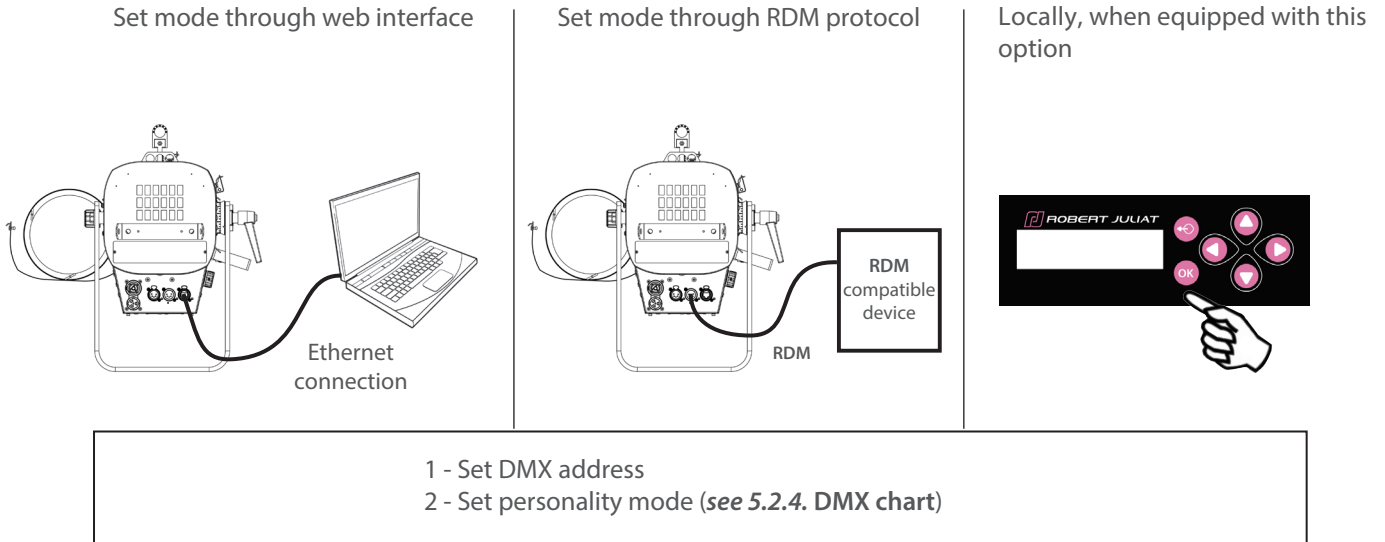

Caution:

Activate DMX in protocol mode beforehand.

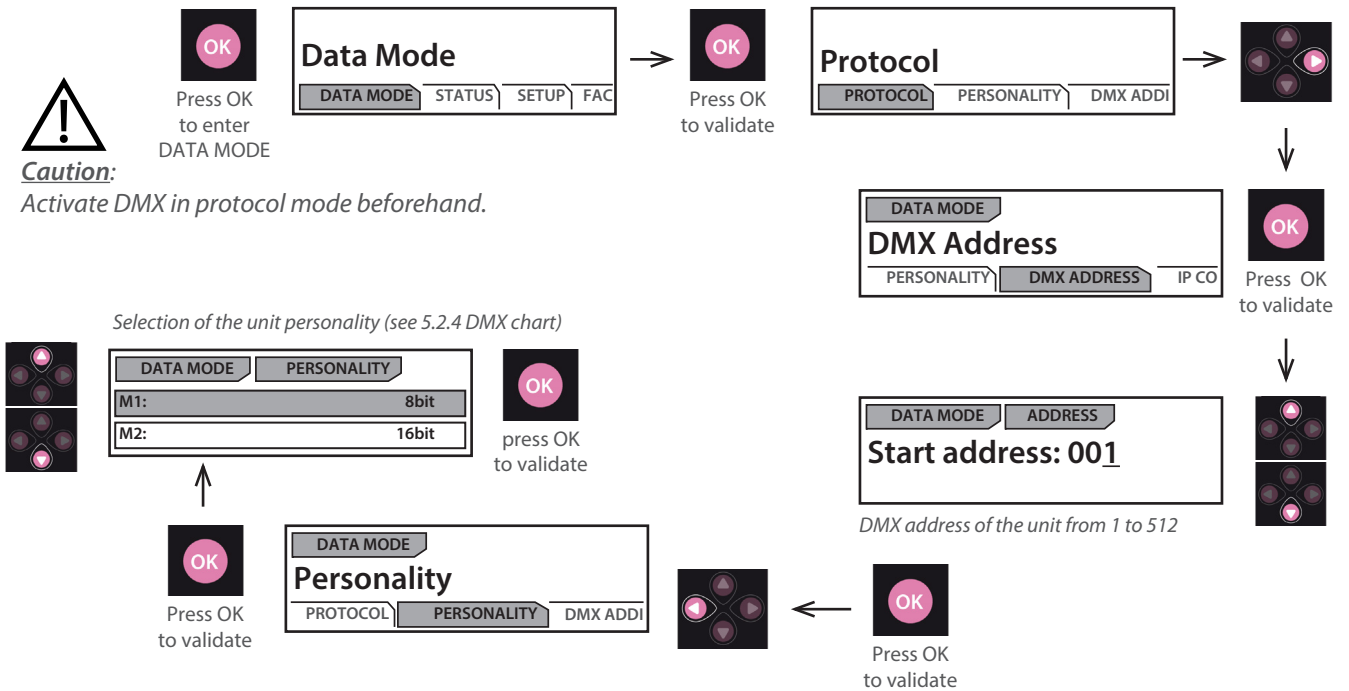

5.2.3.1 DMX Hold

→ Set through RDM protocol, Web interface or local control

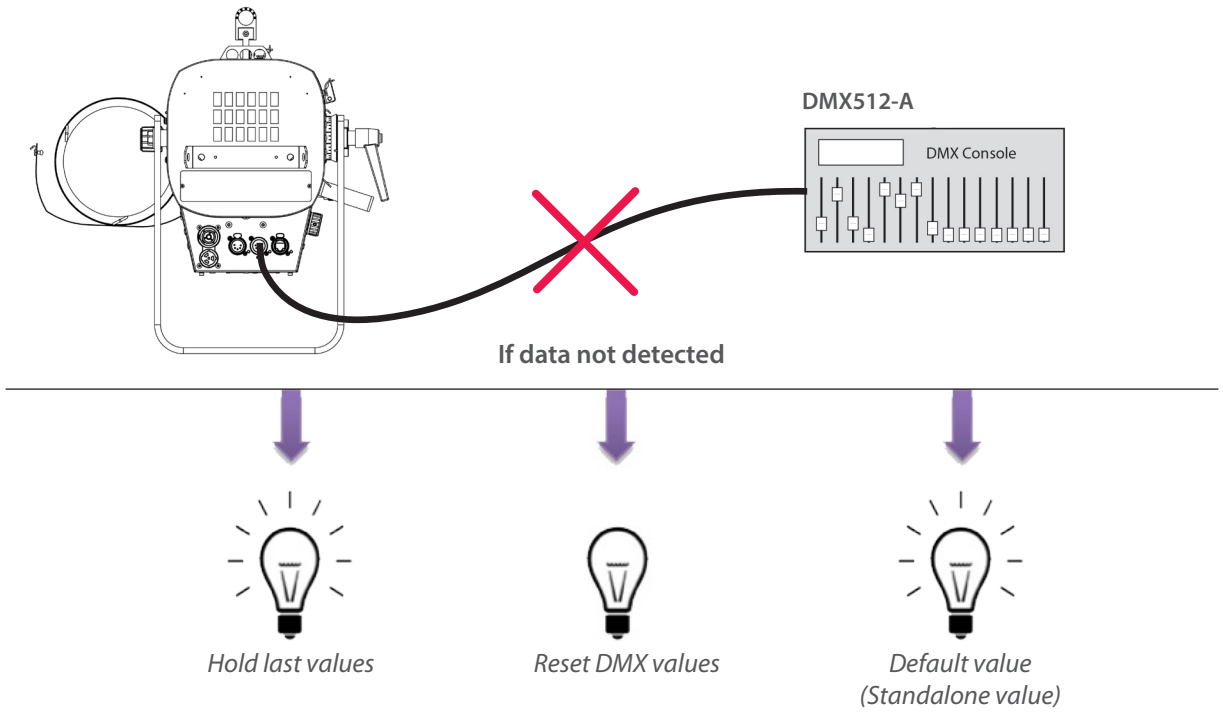

DMX Channel	Mode 1: Dimmer8B	Mode 2: Dimmer16B	Mode 3: Profile8B	Mode 4: Profile16b	Mode 5: Followspot8b	Mode 6: Followspot16b
1	Dimmer	Dimmer	Dimmer	Dimmer	Dimmer	Dimmer
2		Dimmer fine	Strobe duration	Dimmer fine	Master	Dimmer fine
3			Strobe speed	Strobe duration	Strobe duration	Master
4			Response time	Strobe speed	Strobe speed	Master fine
5			Control mode	Response time	Response time	Strobe duration
6				Control mode	Control mode	Strobe speed
7						Response time
8						Control mode

5.2.5 DMX ranges

5.2.5.1 Strobe duration

Range min	Range max	Function
0	0	Strobe OFF
1	255	Strobe ON - 1 ms → 20 ms

5.2.5.2 Strobe speed

Range min	Range max	Function
0	255	Frequency: 0,1 Hz → 10 Hz

5.2.5.3 Response time

Range min	Range max	Function
0	0	OFF
1	255	Response time: 0,20 ms → 4 s

5.2.5.4 Control mode*

Range min	Range max	Function
0	0	
1	10	RDM disabled
11	20	RDM enabled
21	100	not used
101	110	Cooling mode: Silent
111	120	Cooling mode: Normal
121	130	Cooling mode: Full power
131	140	Front Ext disable
141	150	Front Ext enable
151	255	not used

(*) Function activated after 5 seconds - need to go back to zero to activate second function.

5.3.1 Protocol

ANSI E1.20 – 2010 / ANSI E1.37 - 1

For more information about RDM protocol: <http://www.rdmprotocol.org/>

5.3.2 Configuration

PID	Description	Standard	Get	Set	Queued_Message	Ack_Timer	VERSION 4.00
Network Management							
00 01	DISCOVERY_UNIQUE_BRANCH	E1.20					✓
00 02	DISCOVERY_MUTE	E1.20		✓			✓
00 03	DISCOVERY_UNMUTE	E1.20		✓			✓
00 15	COMMUNICATION_STATUS	E1.20	✓	✓			✓
Status Collection							
00 20	QUEUED_MESSAGE	E1.20	✓				✓
00 30	STATUS_MESSAGES	E1.20	✓				✓
00 31	STATUS_ID_DESCRIPTION	E1.20	✓				✓
00 32	CLEAR_STATUS_ID	E1.20		✓			✓
00 33	QUEUED_MESSAGE_SENSOR_SUBSCRIBE	E1.20-2023	✓	✓			
RDM Information							
00 50	SUPPORTED_PARAMETERS	E1.20	✓				✓
00 51	PARAMETER_DESCRIPTION	E1.20	✓				✓
Product Information							
00 60	DEVICE_INFO	E1.20	✓			✓	✓
00 70	PRODUCT_DETAIL_ID_LIST	E1.20	✓				✓
00 80	DEVICE_MODEL_DESCRIPTION	E1.20	✓				✓
00 81	MANUFACTURER_LABEL	E1.20	✓				✓
00 82	DEVICE_LABEL	E1.20	✓	✓	✓	✓	✓
00 90	FACTORY_DEFAULTS	E1.20	✓	✓		✓	✓
00 C0	SOFTWARE_VERSION_LABEL	E1.20	✓			✓	✓
00 C2	BOOT_SOFTWARE_VERSION_LABEL	E1.20	✓				✓
DMX512 Setup							
00 E0	DMX512_PERSONALITY	E1.20	✓	✓	✓	✓	✓
00 E1	DMX512_PERSONALITY_DESCRIPTION	E1.20	✓				✓
00 F0	DMX512_STARTING_ADDRESS	E1.20	✓	✓	✓	✓	✓
01 20	SLOT_INFO	E1.20	✓				✓
01 21	SLOT_DESCRIPTION	E1.20	✓				✓
Sensors							
02 00	SENSOR_DEFINITION	E1.20	✓				✓
02 01	SENSOR_VALUE	E1.20	✓				✓
Dimmer Settings							
03 40	DIMMER_INFO	E1.37-1	✓				✓
03 42	MAXIMUM_LEVEL	E1.37-1	✓	✓	✓	✓	✓
03 43	CURVE	E1.37-1	✓	✓	✓	✓	✓
03 44	CURVE_DESCRIPTION	E1.37-1	✓				✓
03 45	OUTPUT_RESPONSE_TIME	E1.37-1	✓	✓	✓	✓	✓
03 46	OUTPUT_RESPONSE_TIME_DESCRIPTION	E1.37-1	✓				✓
03 47	MODULATION_FREQUENCY	E1.37-1	✓	✓	✓	✓	✓
03 48	MODULATION_FREQUENCY_DESCRIPTION	E1.37-1	✓				✓
Power / Lamp Settings							
04 00	DEVICE_HOURS	E1.20	✓				✓
04 01	LAMP_HOURS	E1.20	✓	✓			✓
Display Settings							
05 01	DISPLAY_LEVEL	E1.20	✓	✓	✓	✓	✓

PID		Description	Standard	Get	Set	Queued_Message	Ack_Timer	SULLY 4.00
Control								
10	00	IDENTIFY_DEVICE	E1.20	✓	✓	✓		✓
10	01	RESET_DEVICE	E1.20		✓		✓	✓
10	20	PERFORM_SELFTEST	E1.20	✓	✓	✓	✓	✓
10	21	SELF_TEST_DESCRIPTION	E1.20					✓
RDMnet Management								
07	00	LIST_INTERFACES	E1.37-2	✓				✓
07	01	INTERFACE_LABEL	E1.37-2	✓				✓
07	02	INTERFACE_HARDWARE_ADDRESS_TYPE1	E1.37-2	✓				✓
07	03	IPV4_DHCP_MODE	E1.37-2	✓	✓		✓	✓
07	05	IPV4_CURRENT_ADDRESS	E1.37-2	✓			✓	✓
07	06	IPV4_STATIC_ADDRESS	E1.37-2	✓	✓			✓
07	09	INTERFACE_APPLY_CONFIGURATION	E1.37-2		✓			✓
07	0A	IPV4_DEFAULT_ROUTE	E1.37-2	✓	✓		✓	✓
07	0B	DNS_IPV4_NAME_SERVER	E1.37-2	✓	✓		✓	✓
PID Manufacturer								
85	58	SELFTEST_RESULT	E1.20	✓				✓
85	59	CURRENT_IP_ADDRESS	E1.20	✓			✓	✓
85	5A	CURRENT_NETMASK	E1.20	✓			✓	✓
85	5B	CURRENT_DRIVER_STATUS	E1.20	✓			✓	✓
85	5C	CUSTOM_RESPONSE_TIME_DESCRIPTION	E1.20	✓				✓
85	5D	CUSTOM_RESPONSE_TIME_VALUE	E1.20	✓	✓	✓	✓	✓
85	60	DATA_MODE_DESCRIPTION	E1.20	✓				✓
85	61	DATA_MODE_VALUE	E1.20	✓	✓	✓	✓	✓
85	62	STANDALONE_VALUE_DESCRIPTION	E1.20	✓				✓
85	63	STANDALONE_VALUE	E1.20	✓	✓	✓	✓	✓
85	64	SACN_UNIVERSE_VALUE_DESCRIPTION	E1.20	✓				✓
85	65	SACN_UNIVERSE_VALUE	E1.20	✓	✓	✓	✓	✓
85	66	ARTNET_UNIVERSE_VALUE_DESCRIPTION	E1.20	✓				✓
85	67	ARTNET_UNIVERSE_VALUE	E1.20	✓	✓	✓	✓	✓
85	68	SERIAL_DESCRIPTION	E1.20	✓				✓
85	69	SERIAL	E1.20	✓	✓	✓	✓	✓
85	6A	DMX_HOLD_DESCRIPTION	E1.20	✓				✓
85	6B	DMX_HOLD	E1.20	✓	✓	✓	✓	✓
85	6C	COMMAND_LOCK_DESCRIPTION	E1.20	✓				✓
85	6D	COMMAND_LOCK_VALUE	E1.20	✓	✓	✓	✓	✓
85	6E	DRIVER_CALIBRATE_DESCRIPTION	E1.20	✓				✓
85	6F	DRIVER_CALIBRATE_VALUE	E1.20	✓	✓	✓	✓	✓
85	70	NODE_DESCRIPTION	E1.20	✓				✓
85	71	NODE_VALUE	E1.20	✓	✓	✓	✓	✓
85	72	TERMINATOR_DESCRIPTION	E1.20	✓				✓
85	73	TERMINATOR	E1.20	✓	✓	✓	✓	✓
85	74	DMX_ERROR_COUNTER_DESCRIPTION	E1.20	✓				✓
85	75	DMX_ERROR_COUNTER	E1.20	✓	✓	✓	✓	✓

5.4.1 Protocol

Artistic Licence Art-Net v3 & v4.

For more information about Art-Net protocol: <http://art-net.org.uk/>

5.4.2 Configuration

Set mode through Web interface
(see 5.7 Web interface)

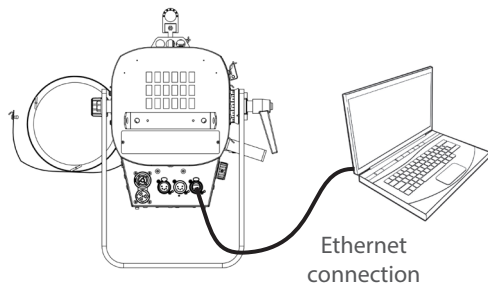

Locally, when equipped with this option

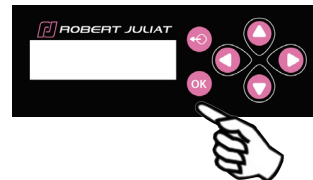

- 1 - If necessary, change IP settings
- 2 - Set Art-Net Universe
- 3 - Set DMX address
- 4 - Set personality mode (see 5.2.4. DMX chart)



Caution:

(*) Activate Art-Net in protocol mode beforehand.

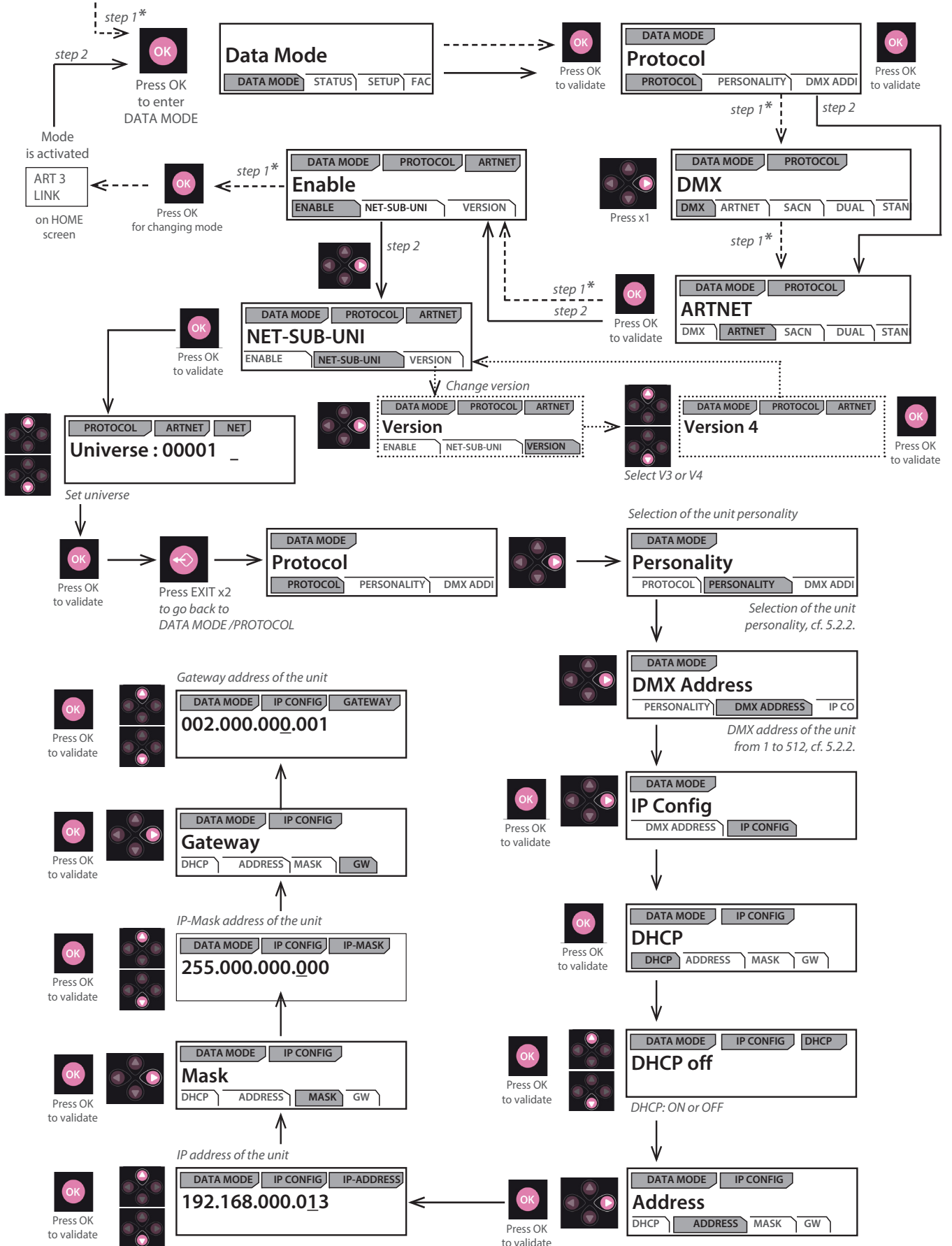

5.5.1 Protocol

ANSI E1.31 – 2009 sACN (Streaming-ACN)

5.5.2 Configuration

Set mode through Web interface
(see 5.7 Web interface)

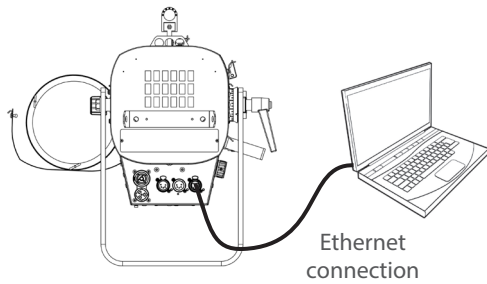

Locally, when equipped with this option

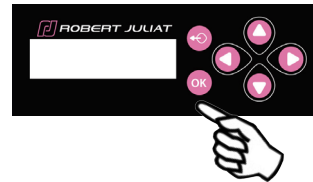

- 1 - If necessary, change IP settings
- 2 - Set sACN universe
- 3 - Set DMX address
- 4 - Set personality mode (see 5.2.4. DMX chart)

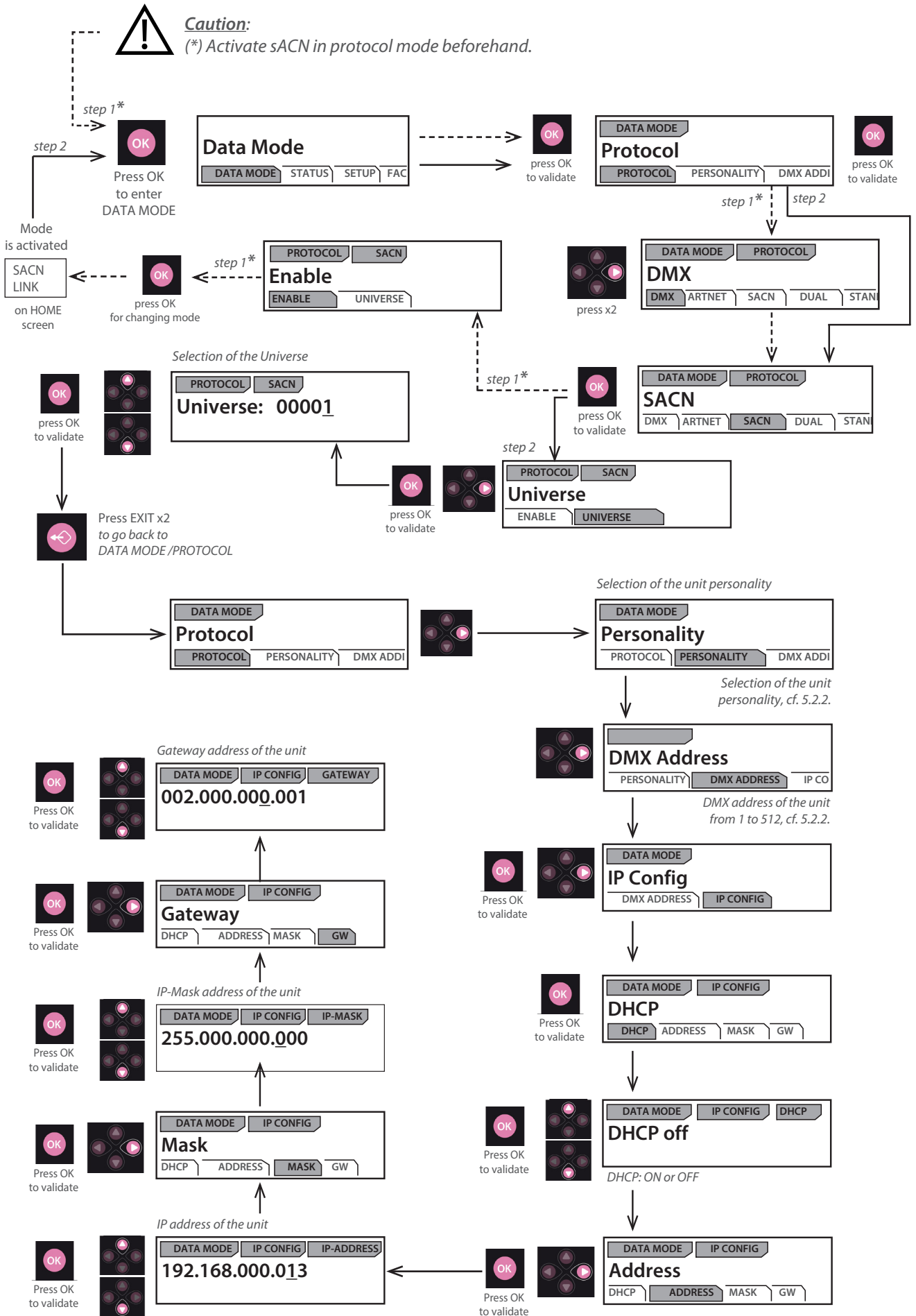

5.6.1 Protocol

Dual Mode: Available only on an Ethernet network

It allows to send a DMX 512 signal through a Sacn data stream and at the same time to use an Artnet/ArtRdm data stream to control, set and monitor the equipment via RDM.

This mode can be set by Web interface or the local control screen.

5.6.2 Configuration

Set mode through Web interface
(see 5.7 Web interface)

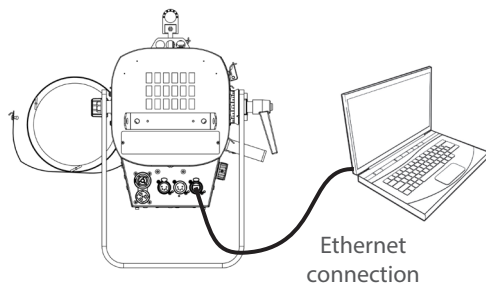

Locally, when equipped with this option

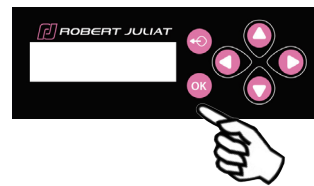

- 1 - If necessary, change IP settings
- 2 - Set DUAL universe
- 3 - Set DMX address
- 4 - Set personality mode (see 5.2.4. DMX chart)

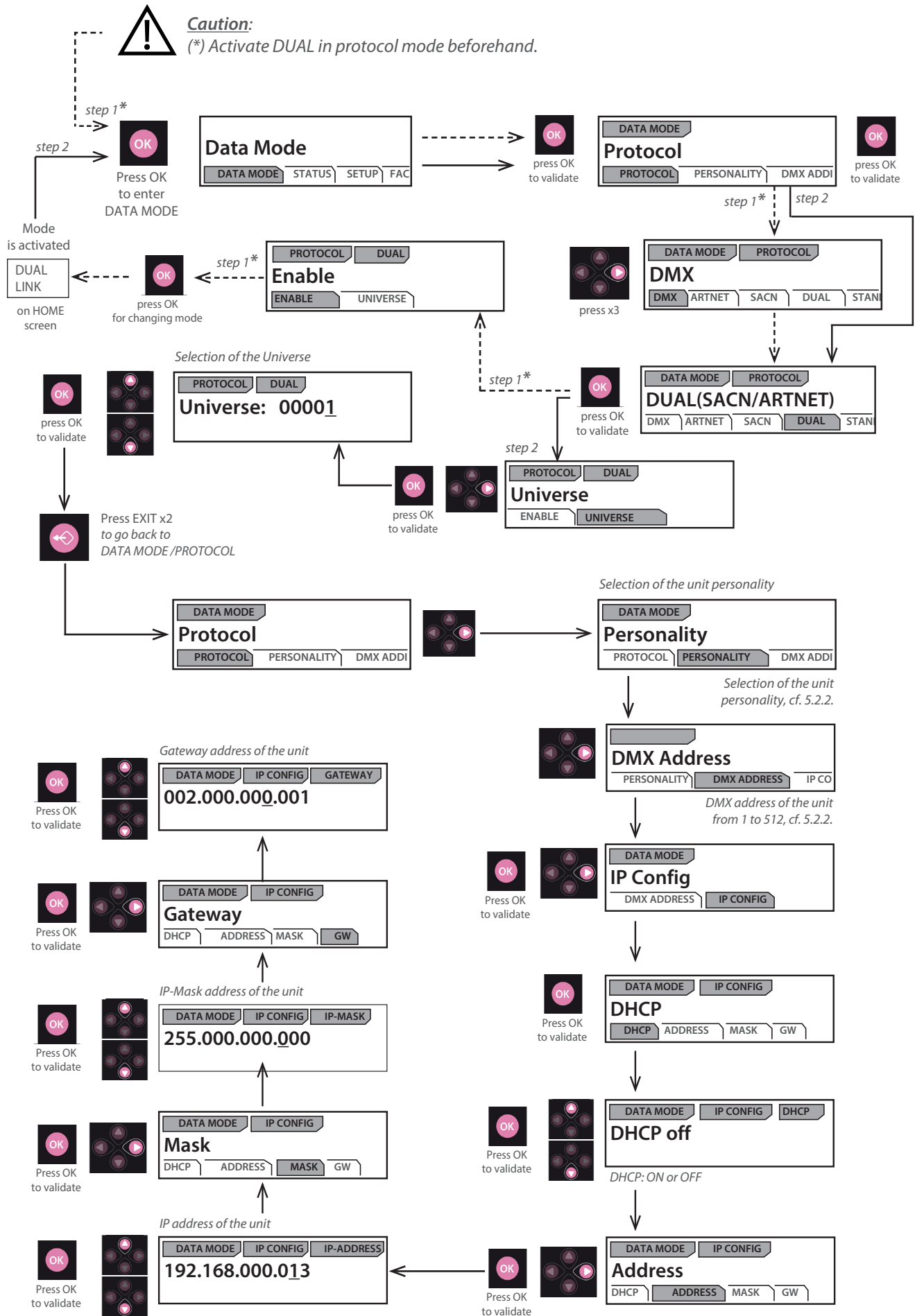

5.7 Web interface



5.7.1 Control

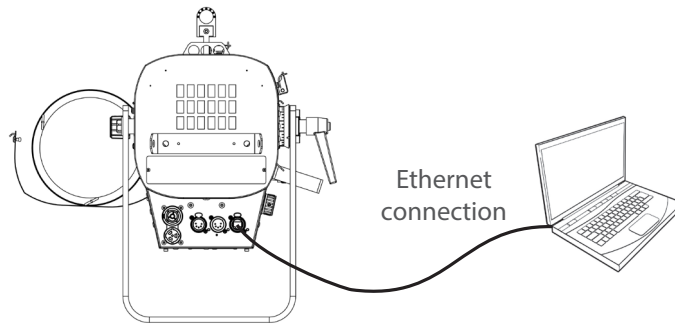

The fixture must be connected to a compatible network or directly to a computer using an ethernet cable.

5.7.2 Default IP address

By default :
DHCP = OFF
Address = 2.XXX.XXX.XXX
Mask = 255.0.0.0

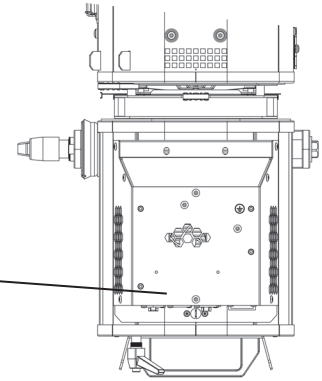

→ If IP address unknown (due to a previous modification), a hard reset must be done (see 6.5 Factory defaults).

5.7.3 Network IP of the computer

The computer must be on the same network as the Sully followspot.

Please refer to your computer Operating System to change IPV4 parameters :

- **Microsoft Windows:**

<https://support.microsoft.com/en-us/windows/change-tcp-ip-settings-bd0a07af-15f5-cd6a-363f-ca2b6f391ace>

- **MAC OS:** <https://support.apple.com/en-gb/guide/mac-help/mchlp2718/10.15/mac/10.15>

1 - ADDRESS = 2.XXX.XXX.YYY with $YYY \neq XXX$

Do not use the same IP address as the Sully followspot

2 - MASK = 255.0.0.0

5.7.4 Connect to web interface

1 - Open a web browser (Microsoft Edge, Firefox, Apple Safari...)

2 - Enter the URL address of the Sully fixture: <http://2.XXX.XXX.XXX>

3 - All parameters can be now modified

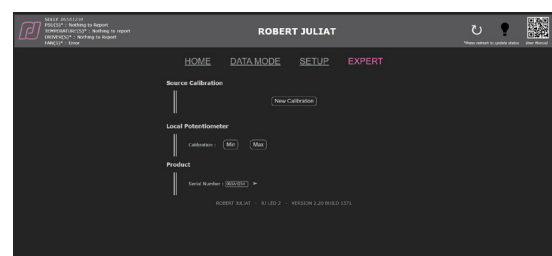
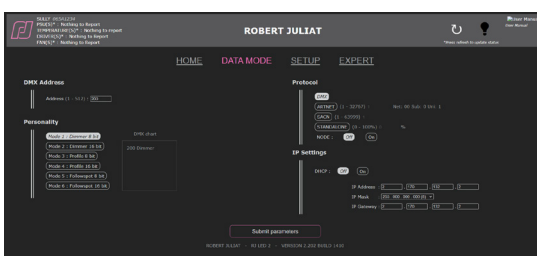
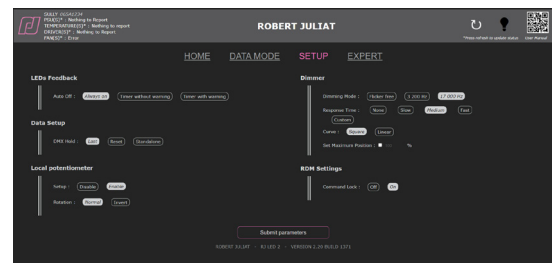
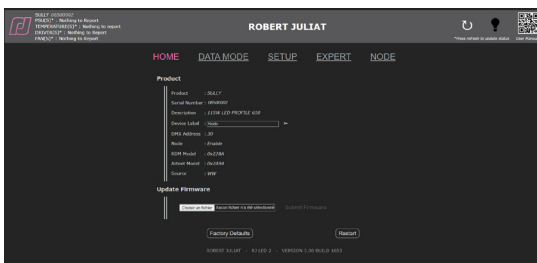



After updating your device with firmware V3.0, we strongly recommend that you update the source type (CCT) either to CW (Cold White) or WW (Warm White) by following the procedure described in the section below: **5.7.5 CCT selection**

5.7.5 CCT selection

Until now, the CCT of the LED source was not taken into account. From V3.0, your device will be automatically recognized as CW or WW source.

Devices shipped with firmware prior to V3.0 do not have a designated CCT. After updating to V3.0, it is highly recommended to specify the CCT of your device. For this you will have to stay on the Web Page that you used for the update.

In the **Source** section of the HOME tab, the CCT of your device is indicated.

- If "unknown", please select the CCT of your device and click on icon **CW** or **WW** then on the arrow **>**.

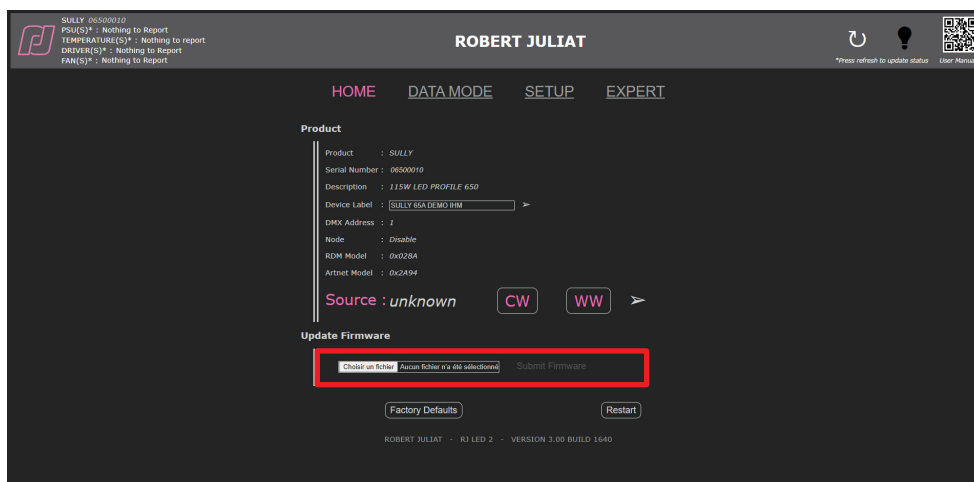

- Changing the source type changes the Model_ID as well. It is used in libraries to recognize devices automatically and for an Auto-Patch.
- If the source type has to be changed or in case of typing error, it will be always possible to change the source type in the Expert mode which is protected by a password.

5.8 LEDs Feedback

5.8.1 Trouble shooting

• During unit initialisation (power up) – up to 5 seconds:

1 DMX OUT	2 DMX IN	3 Network	Description
Ⓟ	Ⓟ	Ⓟ	Unit OFF
Ⓡ	Ⓡ	Ⓡ	Unit error
Ⓢ	Ⓢ	Ⓢ	Unit has been reset successfully
Ⓟ	Ⓟ	Ⓡ or Ⓢ or Ⓟ	RDM protocol activated

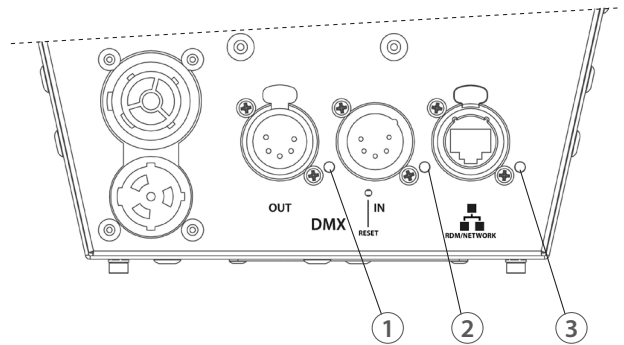

• After initialisation - Node mode "OFF":

1 DMX OUT	2 DMX IN	3 Network	Description
Ⓟ	Ⓟ	Ⓟ	Display auto-off
Ⓟ	Ⓢ	Ⓡ	No ethernet
Ⓟ		Ⓢ	Ethernet detected (link)
Ⓟ		Ⓟ	Ethernet detected + data
Ⓟ	Ⓟ	Ⓡ	No ethernet
Ⓟ		Ⓢ	Ethernet detected (link)
Ⓟ		Ⓟ	Ethernet detected + data
Ⓟ	Ⓡ	Ⓡ	No ethernet
Ⓟ		Ⓢ	Ethernet detected (link)
Ⓟ		Ⓟ	Ethernet detected + data
Ⓡ	Ⓡ	Ⓡ	Unit error
Ⓟ	Terminator ON		

• After initialisation - Node mode "ON":

1 DMX OUT	2 DMX IN	3 Network	Description
Ⓟ	Ⓟ	Ⓟ	Display auto-off
Ⓢ	Ⓢ	Ⓡ	No ethernet
		Ⓢ	Ethernet detected (link)
		Ⓟ	Ethernet detected + data
Ⓟ	Ⓟ	Ⓡ	No ethernet
		Ⓢ	Ethernet detected (link)
		Ⓟ	Ethernet detected + data
Ⓡ	Ⓡ	Ⓡ	No ethernet
		Ⓢ	Ethernet detected (link)
		Ⓟ	Ethernet detected + data
Ⓡ	Ⓡ	Ⓡ	Unit error

5.8.2 Parameters

5.8.2.1 Intensity

➔ Set through RDM protocol or web interface

Mode	Description
Display level	Adjust the intensity of the feedback LEDs

5.8.2.2 Auto-OFF

➔ Set through RDM protocol or web interface

Mode	Description
Always ON	Feedback LED, always ON
Timer without warning	Feedback LED OFF after 20 seconds
Timer with warning	Feedback LED OFF after 20 seconds, ON, if warning information occurs

6.1 Preventive maintenance

6.1.1 Frequency

General maintenance should be performed at least once a year or more frequently if the equipment is operated in adverse conditions (smoke, heat, humidity, touring, etc.).

6.1.2 General cleaning

Remove dust from the unit.

Front glasses can be cleaned with solutions containing alcohol.

6.1.3 General visual check

- No trace of heat.
- No loose contacts.
- No missing parts.
- Tighten mechanical assemblies (screws, bolts and nuts, etc.).

6.1.4 LED source



- Do not touch the surface of the LED source (no contact with your hands or any tools).
- Do not put compressed air directly on the source.
- Contact a certified RJ distributor in case of residuals or other objects located on the surface of the LED source.

6.1.5 Optics

Only use solutions containing alcohol to clean optical parts (lenses).

- To clean the optical parts, use a soft cloth in combination with distilled water or isopropyl alcohol recommended for coated optics. Do not use any cleaning product that contains solvents or abrasives, as these can cause surface damage.
- Dry with a soft lint-free cloth.

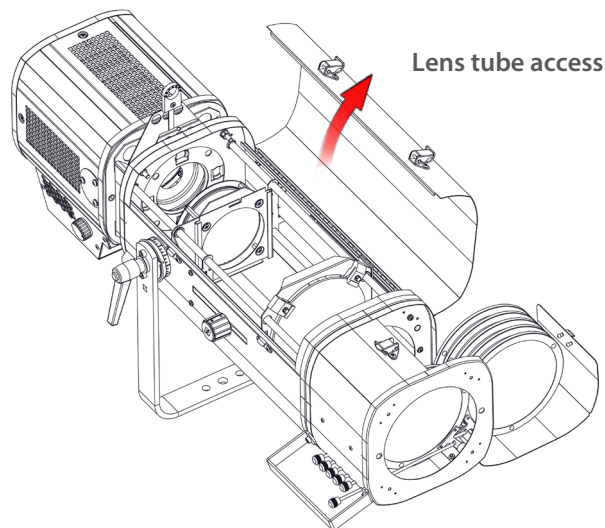

6.1.6 LED house cleaning

Inner parts & lens holder access:

- To clean the optical parts, use a soft cloth in combination with distilled water or isopropyl alcohol recommended for coated optics. Do not use any cleaning product that contains solvents or abrasives, as these can cause surface damage.
- Dry with a soft lint-free cloth.
- The double condenser system (aspheric and biconvex lenses) can easily be removed, without tools, by loosening the two wing nuts. The complete holder can then be removed for cleaning.

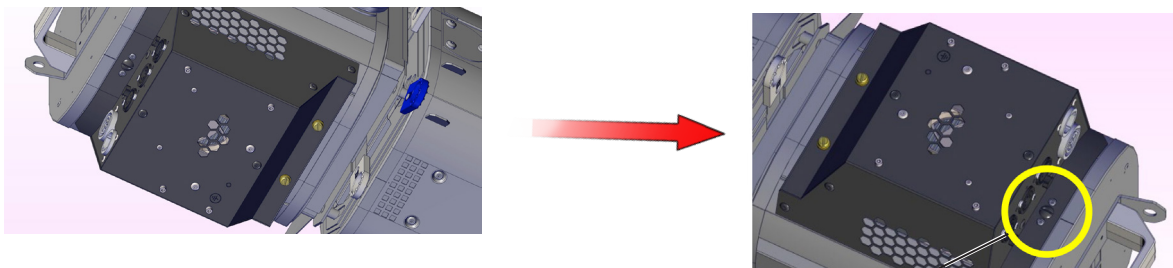

How to remove the Sully LED compartment for cleaning:

1. We recommend you place your luminaire on a flat clean surface.
Disconnect from the mains before servicing.
2. Unlock the quarter turn screw with a flat screwdriver.
3. Remove the two screws with a flat screwdriver.
4. Slightly slide out the LED compartment and remove the earth attachment before removing it completely from it's housing.
5. Carefully place the LED compartment on a flat clean surface.

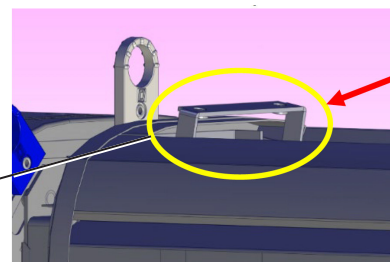
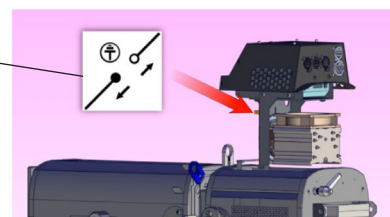
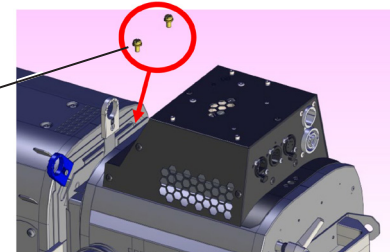

Sully LED compartment installation:

6. Extend the hinge to its maximum position to make it easily accessible. Insert the LED compartment into your luminaire, making sure it is positioned vertically to enable the LED compartment to enter the lamp house correctly.
7. Connect the ground connection (faston tab terminal) to the Sully LED compartment.
8. Once the LED compartment is fully inserted, remount tightly the two screws nearest the shutter gate. Re-tighten the quarter turn screw located at the back of the lamp base to lock the LED compartment securely into your luminaire.

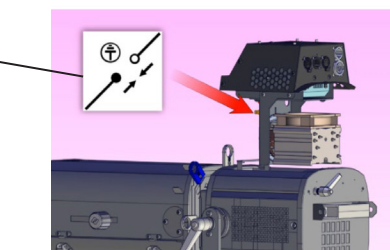

6.2 Analysis

In case of problem, contact RJ distributor with the following information:

- Model, version and serial number of the product.
- From the menu status:
 - Software version
 - LED board IDs
 - Device hours
- Description of the problem.



6.3 Electronic thermal management system

In case of overheating, light intensity will be reduced by the system.
Power reduction and temperature values are available by using a RDM protocol compatible device.

6.4 Firmware update



After updating your device with firmware V3.0, we strongly recommend that you update the source type (CCT) either to CW (Cold White) or WW (Warm White) by following the procedure described in the section below: **CCT selection**

CCT selection

Until now, the CCT of the LED source was not taken into account. From V3.0, your device will be automatically recognized as CW or WW source.

Devices shipped with firmware prior to V3.0 do not have a designated CCT.
After updating to V3.0, it is highly recommended to specify the CCT of your device.
For this you will have to stay on the Web Page that you used for the update.

In the **Source** section of the HOME tab, the CCT of your device is indicated.

- If "unknown", please select the CCT of your device and click on icon **CW** or **WW**, then on the arrow **>**.

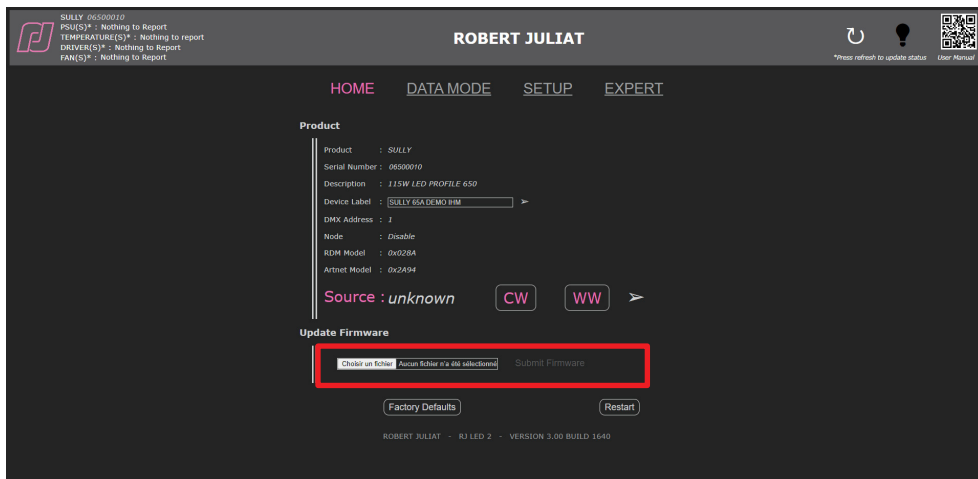

- Changing the source type changes the Model_ID as well. It is used in libraries to recognize devices automatically and for an Auto-Patch.
- If the source type has to be changed or in case of typing error, it will be always possible to change the source type in the Expert mode which is protected by a password.

1. Firmware available on www.robertjuliat.com/followspots/SULLY_1156
2. Download and unzip the file
There are 4 files:
 - Firmware (.upd2 format)
 - Firmware History
 - Update Procedure
 - User Manual from firmware V3.0
3. Switch on the unit
4. Connect Network from computer to the unit
5. Open a web browser (Internet Explorer, Firefox, Chrome...)
6. Enter the URL address to connect to the web interface (*see 5.7*)
7. Upload your firmware file (.upd2) in the "Update firmware" section and then click on 'Submit firmware'

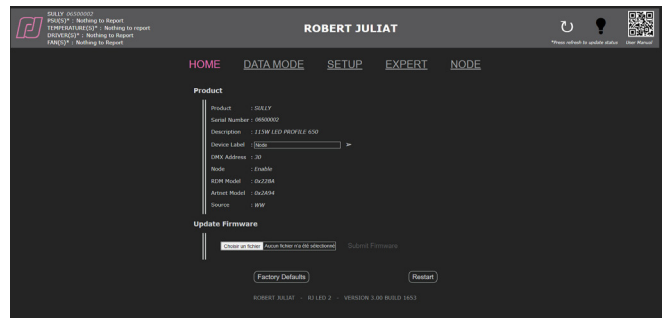

6.5 Factory defaults

6.5.1 Modes

Mode	Description
Restart	Software reset – all user parameters are kept
Factory defaults	Set all user parameters to factory default value

6.5.2 Control

Set to factory defaults / reset through web interface (Home page)

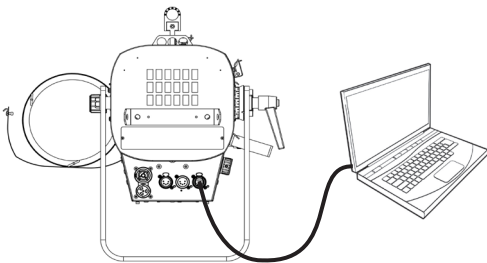

Set to factory defaults / reset through RDM protocol

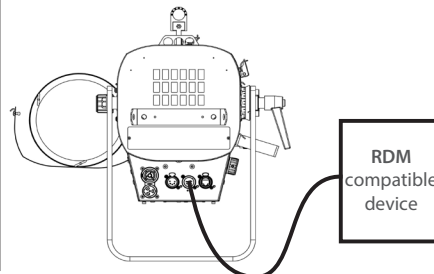

Set to factory defaults / reset through local control, when equipped with this option

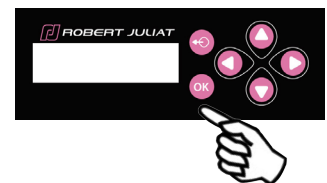

→ If IP address unknown (due to a previous modification), IP address can be read from RDM protocol or a **hard reset** must be done:

The diagram shows the rear panel of the unit with four ports: OUT, DMX, IN, and RDM NETWORK. A dashed line labeled 'Reset' points to a small button located between the DMX and IN ports.

While holding down the **reset** button with a paper clip, connect the unit to power and continue to hold the reset button until the 3 status light turn green.
The system is then ready for setup.



Press OK to start SELFTEST

STATUS		
SELFTEST		
SELFTEST	SYSTEM ID	LIGHT SOUP



There are 9 tests available that will be performed by the fixture. At the end of each test, a PASS/FAIL message will be displayed.

FANS PASS

Fan Test

POWER PASS

PSU Test

TEMPERATURE SENSORS PASS

Temperature Test

NETWORK Network fail or no network

Network Test
A data connection is required.

DRIVER Test in progress

Driver Test
Each driver is tested individually and a calibration is launched if required.

DRIVER Calibration in progress

DRIVER PASS

Main Power Stress PASS

48V PSU Stress Test



Press OK

POTENTIOMETER Turn potentionmeter to maximum then press OK

Dimmer Potentiometer Test
Follow the instructions.

POTENTIOMETER Side / Top ctrl => press UP Top ctrl inv => press DOWN
--

DMX IN
DMX IN fail or NO DMX

DMX Test

DMX data is required to complete this test.

DMX OUT
Plug DMX OUT then press OK

DMX OUT
DMX OUT fail or NO DMX

LEDS
green

Signal Leds Test

LEDS
blue

LEDS
red

test report: Fail		P=Pass F=Fail	
fans P	pow P	temp P	dmxi P
dmxo F	net F	drv P	pot P

Test Report

To be communicated to **RJ Service** if requested :
service@robertjuliat.fr