

# ALICE & OZ

## FOLLOWSPOTS

Manual

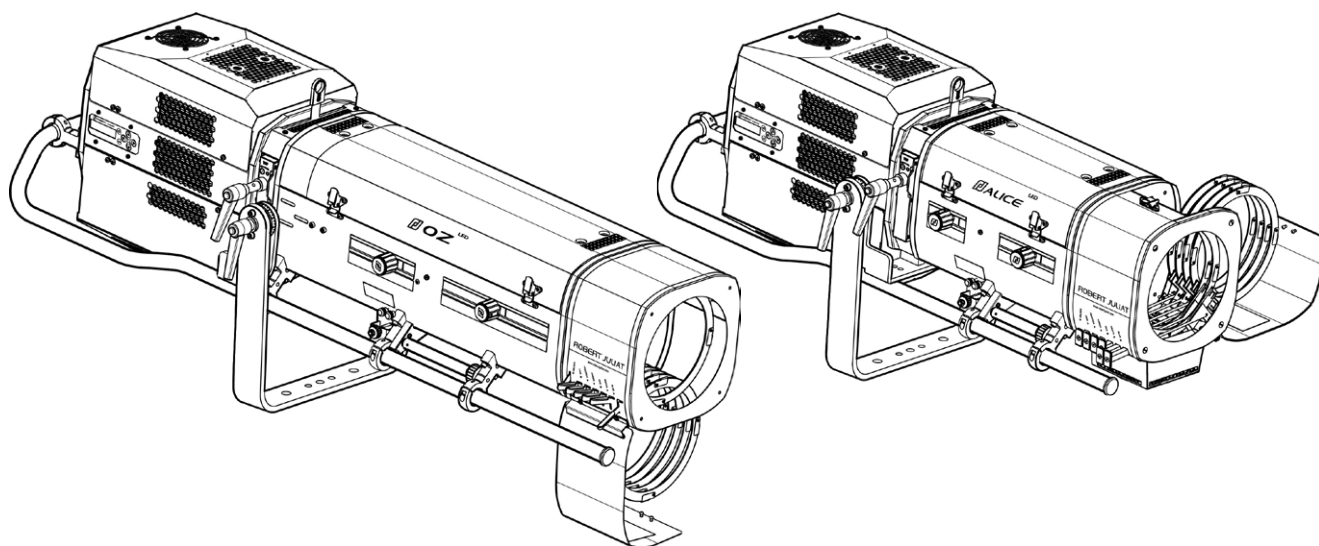

Model	Standard	North American
7 – 14,5°	OZ 1169	OZ 1169C
13 – 24°	ALICE 1469	ALICE 1469 C

### 600W LED FOLLOWSPOTS

Oz - 1169 V1a / Alice - 1469 V1a  
Firmware V1.9 – 10/09/18

VALIDATION: 27/09/18

**DN41135200**



**ROBERT JULIAT**

## Table of Contents

1	User's instructions.....	1
2	Presentation.....	2
2.1	Functions.....	2
2.2	Identification label.....	3
2.3	Accessories included.....	3
2.4	Optional accessories.....	4
3	Set-up.....	5
3.1	Mechanics.....	5
3.1.1	Operating positions.....	5
3.1.2	Minimum distance between a flammable material and the lighting unit.....	5
3.1.3	Instructions for use.....	5
3.1.4	Lifting.....	5
3.1.5	Stand set-up.....	6
3.2	Electrical information.....	7
3.2.1	LED source.....	7
3.2.2	Power supply.....	7
3.3	DATA.....	8
3.3.1	Data 512-A / RDM.....	8
3.3.2	Art-Net / sACN.....	8
3.3.3	Ethernet / DMX mode.....	9
3.3.4	Wireless DMX.....	9
3.4	Accessories.....	10
3.4.1	Full closing iris cassette.....	10
3.4.2	Colour changer unit - boomerang (only available for OZ).....	10
3.4.3	Colour changer unit - push-pull (ALICE).....	11
3.4.4	Gobo holder.....	11
3.4.5	Double slot front cassette.....	12
3.4.6	Frosted / CTO glass.....	12
3.4.7	Internal glass holder.....	13
3.4.8	Horizontal chopper.....	13
3.4.9	Stands.....	14
3.4.10	Heavy duty adjustable yoke.....	14
3.4.11	Telrad followspot sight.....	14
3.4.12	Flight-case.....	15
4	Operations.....	16
4.1	Light intensity.....	16
4.1.1	Range.....	16
4.1.2	Control.....	16
4.1.3	Parameters.....	16
4.1.3.1	Dimming resolution.....	16
4.1.3.2	Dimming curve.....	16
4.1.3.3	Master control.....	17
4.1.3.4	Set maximum position.....	17
4.1.3.5	Sensitivity.....	17
4.2	Strobe.....	18
4.2.1	Range.....	18
4.2.2	Control.....	18
4.3	Response time.....	18
4.3.1	Range.....	18
4.3.2	Control.....	18
4.4	Beam size adjustment.....	19
4.4.1	Range.....	19
4.4.2	Control.....	19
4.5	Pan / Tilt.....	20
4.5.1	Range.....	20
4.5.2	Control.....	20
4.6	Iris.....	21
4.6.1	Range.....	21
4.6.2	Control.....	21
4.7	Gobo.....	21
4.7.1	Range.....	21
4.7.2	Control.....	21
4.8	Colour.....	22
4.8.1	Range.....	22
4.8.2	Control.....	22
4.9	Frost and correction filters.....	23
4.9.1	Range.....	23
4.9.2	Control.....	23
4.10	Horizontal chopper.....	24
4.10.1	Range.....	24
4.10.2	Control.....	24
5	Controls and parameters.....	25
5.1	Local display and controls.....	25
5.1.1	Display.....	25
5.1.2	Menu.....	26
5.1.3	Parameters.....	27
5.2	DMX512 - A remote control.....	28
5.2.1	Protocol.....	28
5.2.2	Configuration.....	28
5.2.3	Parameters.....	28
5.2.3.1	DMX Hold.....	28
5.2.4	DMX chart.....	29
5.2.5	DMX ranges.....	29
5.2.5.1	Strobe duration.....	29
5.2.5.2	Strobe speed.....	29
5.2.5.3	Response time.....	29
5.2.5.4	Control mode.....	29
5.3	RMD remote control.....	30
5.3.1	Protocol.....	30
5.3.2	Functions.....	30
5.3.3	Parameters ON/OFF.....	30
5.4	Art-Net remote control.....	31
5.4.1	Protocol.....	31
5.4.2	Configuration.....	31
5.5	sACN remote control.....	32
5.5.1	Protocol.....	32
5.5.2	Configuration.....	32
5.6	Fan cooling modes.....	33
5.6.1	Range.....	33
5.6.2	Control.....	33
6	Service.....	33
6.1	Preventive maintenance.....	33
6.1.1	Frequency.....	33
6.1.2	General cleaning.....	33
6.1.3	General visual check.....	33
6.1.4	LED source.....	33
6.1.5	Optics.....	34
6.1.6	Inner fans & LED glass protection cleaning.....	34
6.2	Analysis.....	34
6.3	Local potentiometer.....	35
6.4	Electronic thermal management system.....	35
6.5	Firmware update.....	35
6.6	Exploded view / Spare parts list.....	35

# 1 User's instructions

## GENERAL INSTRUCTIONS

1. Not for residential use.
2. **These fixtures must only be serviced by a qualified technician.**
3. In addition to the instructions indicated on this page, relevant health and safety requirements of the appropriate EU Directives must be adhered to at all times.
4. This fixture is in compliance with section 17 - Lighting appliance for theatre stages, television, cinema and photograph studios. Standards NF EN 60598-1, NF EN 60598-2-17, Low Voltage Directive 2014/35/UE & EMC Directive 2014/30/UE.
5. This fixture is rated as IP20, and is for indoor use only.

## FIXTURE

6. Ensure fixture is correctly mounted on an appropriate support.
7. Protection screens and lenses must be replaced in the event of any damage, such as cracks or deep scratches, since these might reduce performance.
8. When hung or flown the fixture must be secured by an additional hanging accessory (such as a safety cable or bond) of suitable length.
9. Safety bonds or cables must be securely attached to the back of the fixture and be as short as possible, or rolled up as necessary, to minimise travel distance should the fixture be dislodged.
10. Movable accessories (scroller, etc.) must also be secured with a suitable safety cable or bond at the front of the fixture.
11. The combined weight of both the fixture and the accessories must be considered when choosing the load-bearing capability of safety cable or bond.
12. Do not open lighting fixture when the source is on.
13. **WARNING:** LED source become hot during use. Allow fixture to cool before servicing.
14. Do not tamper with design of fixture nor any of its safety features.
15. Tighten electrical mains cable connections regularly and replace with one of identical specification if damaged.
16. Use only with correct power supply.

## VENTILATION

17. Keep well away from flammable material.
18. Not for outdoor use. Do not cover. Do not permit fixture to get wet.
19. To avoid overheating, do not obstruct air vents.
20. Ensure any cooling fans are in correct working order. If fans are not working, turn fixture off immediately and service as necessary.

## CLEANING

21. Do not touch LED source with fingers.
22. Clean all optical parts with alcohol-based cleaner.
23. Clean all filters regularly.

## POWER SUPPLY

24. Disconnect from the mains before servicing.
25. Mains connection only. Do not connect to "electronic output" such as dimmer.
26. Not for outdoor use. Do not cover.
27. Ensure power supply circuit breakers, always remain accessible.

## PLEASE NOTE

These products have been built to conform to European standards relating to professional lighting equipment. Any modification made to our products will void the manufacturers' warranty.

**Risk group 2**



**CAUTION:** Possibly hazardous optical radiation emitted from this product.  
Do not stare at operating lamp.  
Maybe harmful to the eye.

## Photobiological safety according to EN62471

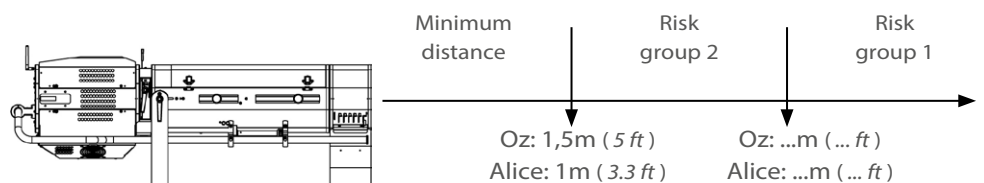

## 2 Presentation

### 2.1 Functions

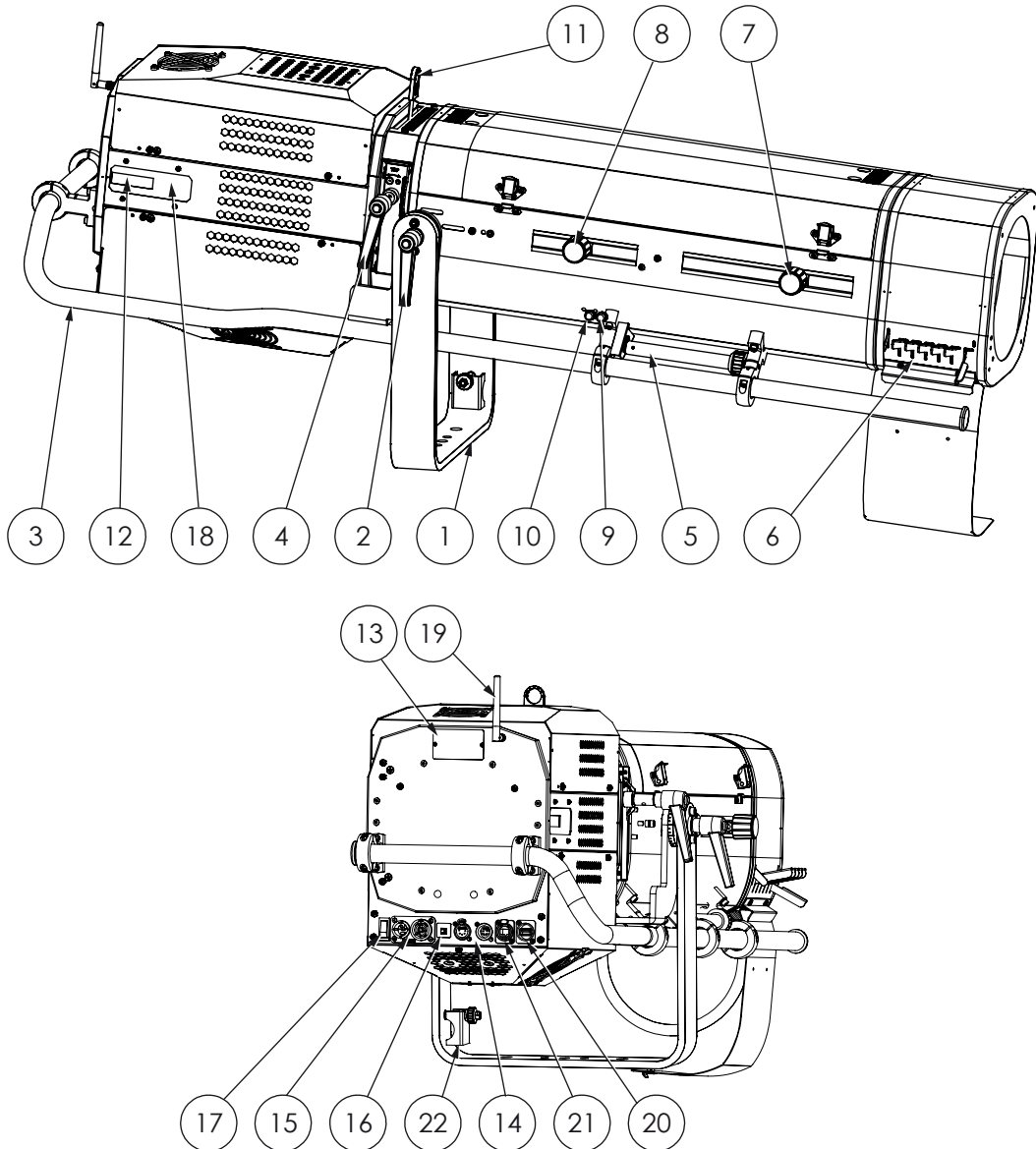

Functions	
1. Yoke	12. Local display
2. Yoke locking	13. Identification plate
3. Side operating	14. Data connectors (OUT and IN)
4. Iris control	15. Power connectors (IN and OUT)
5. Dimming control	16. Thermal breaker
6. Colour changer	17. Power switch
7. Focus adjustment	18. Control board
8. Zoom adjustment	19. Wireless DMX antenna (option)
9. Frost glass	20. USB connector
10. Spare filter	21. RJ45 connector
11. Gobo holder	22. Cable lock

Description	
<p><b>LED FIXTURE</b> Risk Group </p> <p>Lire le manuel avant utilisation - Utilisation et maintenance par professionnel uniquement / Read manual before use - Service only by qualified personnel.</p> <p>MOD. <b>1</b> VERS. <b>2</b> <b>11</b> </p> <p>U <b>3</b> I <b>4</b> </p> <p>P <b>5</b> IP <b>6</b> </p> <p>t<sup>a</sup> <b>7</b> t<sup>c</sup> <b>8</b> </p> <p><b>ROBERT JULIAT.com</b> Made in the EU - France - </p>	<ol style="list-style-type: none"> <li>1. MOD. : Model</li> <li>2. VERS. : Version</li> <li>3. U : Nominal voltage input (V)</li> <li>4. I : Nominal intensity (A)</li> <li>5. P : Maximum power input (W)</li> <li>6. IP : International Protection Rating</li> <li>7. t<sup>a</sup> : Maximum ambient temperature (°C)</li> <li>8. t<sup>c</sup> : Maximum external temperature of the unit (°C)</li> <li>9. Net weight (kg)</li> <li>10. Minimum distance between a flammable material and the lighting unit (m)</li> <li>11. Colour temperature version</li> <li>12. Serial number</li> <li>13. Replace broken glass</li> <li>14. Class 1 product label</li> <li>15. Read manual first label</li> <li>16. European conformity label</li> <li>17. WEEE directive label</li> <li>18. EN62471 - Risk group</li> <li>19. CEI-TR-62778 - Do not stare at light source</li> </ol>
<p><b>Units :</b></p> <ul style="list-style-type: none"> <li>- Weight = kilogram (kg).</li> <li>- Intensity = Ampere (A).</li> <li>- Voltage = Volt (V).</li> <li>- Frequency = Hertz (Hz).</li> <li>- Temperature = degree Celsius (°C).</li> </ul>	

2.3 Accessories included

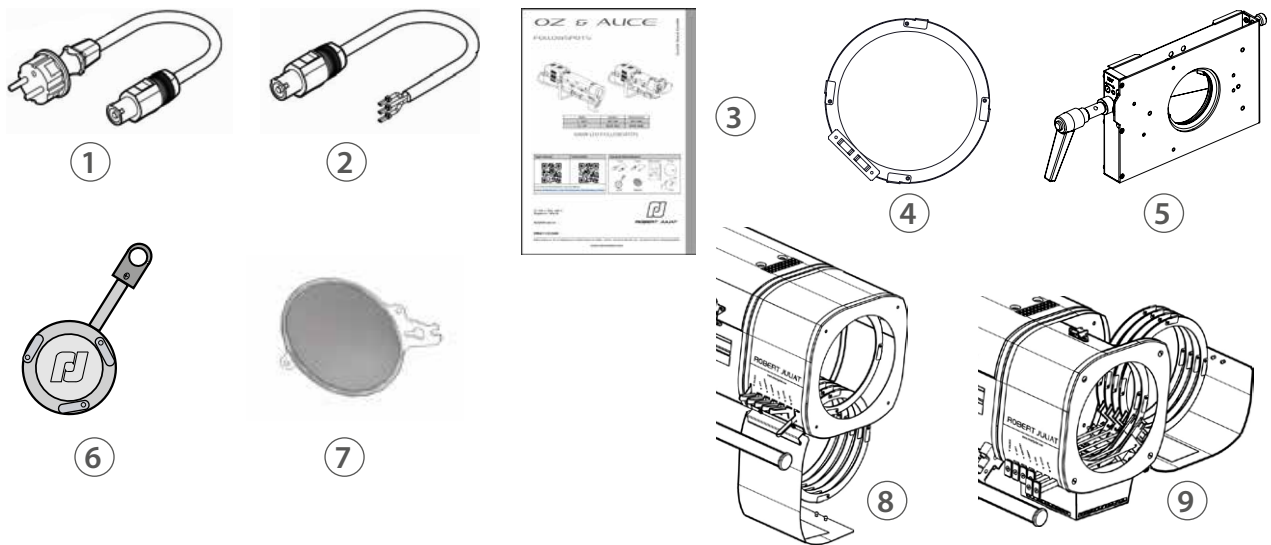

	Reference	Description
1	CAL03	3 meter power cable ( 3G1,5 HO7RNF) with Neutrik PowerCon© True1 and CEE 7/7 (2P+T NF/SCHUKO) connectors (standard version)
2	CAL04	1,50m power cable UL/CSA with Neutrik® powerCON TRUE1 connector (North American version)
3	DN41145300	Quick Start manual
4	PF1011	Ø210 mm metal filter holder (x6)
5	CCU1	Full closing iris cassette
6	SGUP	Universal "A" size gobo-holder (metal, glass, frosted glass)
7	VDM100	Ø97mm frosted glass with holder
8	M210B	6-way "boomerang" colour changer (only available for OZ)
9	M210T	6-way "Push/Pull" colour changer (included with ALICE, as an option for OZ)

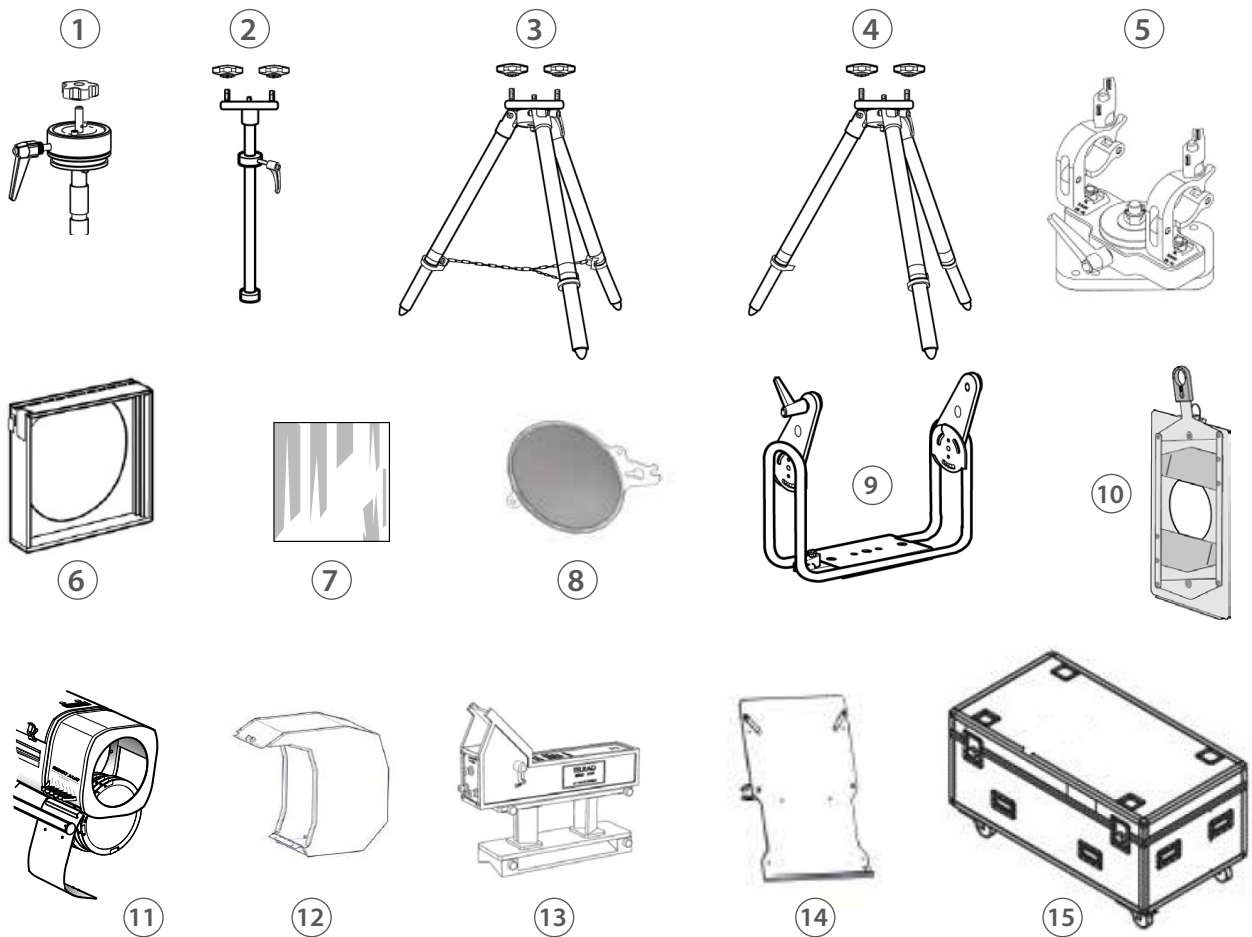

	Reference	Description
1	T1000	TV spigot with followspots swivel head
2	JPP	Monopod stand for overhead followspot
3	GT4000	Tripod stand with safety chain - SWL: 130 Kg - max. height: 1030 mm
4	GT4000S	Tripod stand without safety chain - SWL: 130 Kg - max. height: 1030 mm
5	T4000	Followspot mount for Ø50mm pipe (suspension or overhead) - SWL= 100 Kg
6	CAV700A	Double slot front cassette for 215x215mm accessories
7	VD120	120x120mm frosted glass
8	FCM100	Ø97mm CTO correction filter (5500K —> 3400K) with holder
9	FRO/1017PD	Heavy duty adjustable yoke
10	Kit G80	Ø80mm chopper kit (G80+ GR120+ adaptation kit)
11	M210B	6-way "boomerang" colour changer (only available for OZ)
12	M210TVCL	Light shield for M210T push/pull coulour changer
13	Kit TELRAD	Telrad followspot sight with raiser and universal mounting kit
14	SDUP	Followspot cue sheet holder with universal mounting kit
15	FC1169/S	Flight-case for Compact range (LED version) / GT stand / P.S.U. / accessories

# 3 Set-up

## 3.1 Mechanics

### 3.1.1 Operating positions for OZ & ALICE



### 3.1.2 Minimum distance between a flammable material and the lighting unit

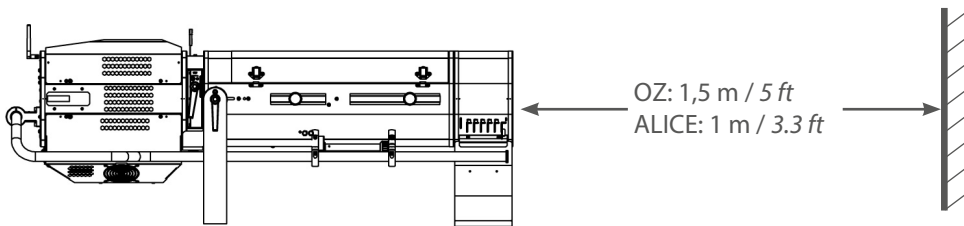

### 3.1.3 Instructions for use

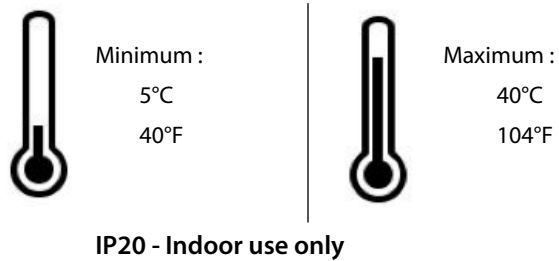

### 3.1.4 Lifting

- Net weight for  
OZ : 41 Kg (90.2 lbs)  
ALICE 40 Kg (88 lbs)

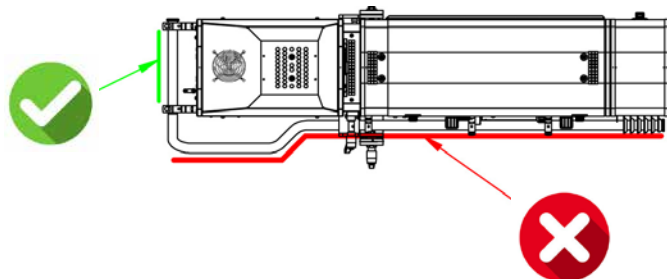

### 3.1.5 Stand set-up

The unit must be installed only on a Robert Juliat compatible stand / head :	
T1000	TV spigot with followspots swivel head
JPP	Monopod stand for overhead followspot
GT4000	Tripod stand with safety chain - SWL: 130 Kg - max. height: 1030 mm
GT4000S	Tripod stand without safety chain - SWL: 130 Kg - max. height: 1030 mm
T4000	Followspot mount for Ø50mm pipe (suspension or overhead) - SWL= 100 Kg

- GT4000 & GT4000S

*Please refer to the relevant stand technical files for further details.*

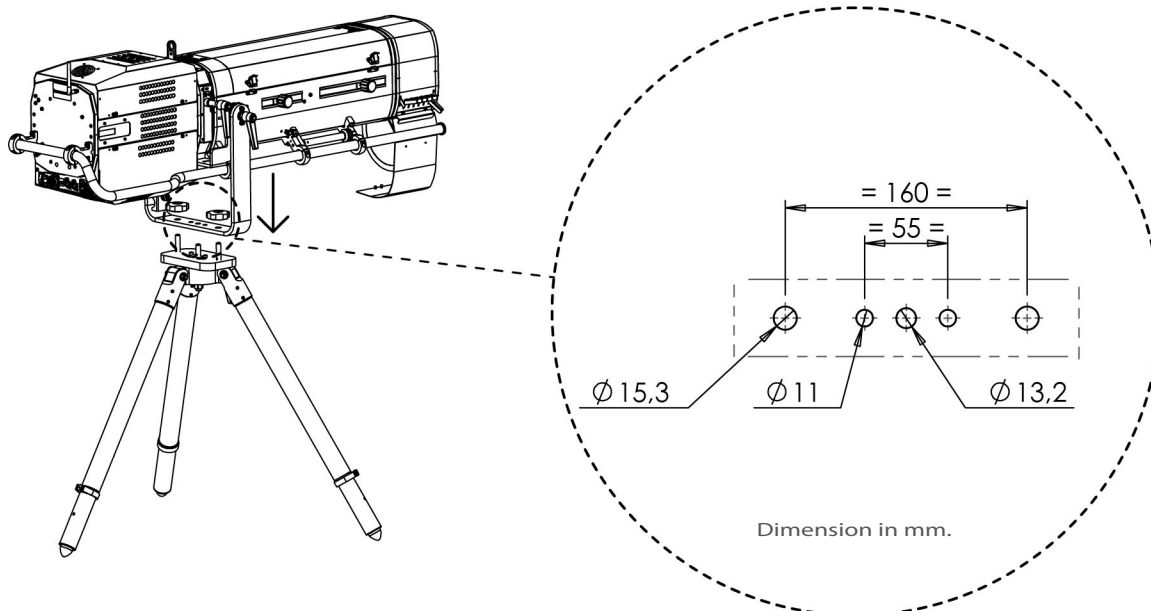

### 3.2 Electrical information



#### 3.2.1 LED source



**Never touch or scratch the LED surface.**  
Cf. 6.1.4 LED cleaning procedure if cleaning is necessary.

#### 3.2.2 Power supply

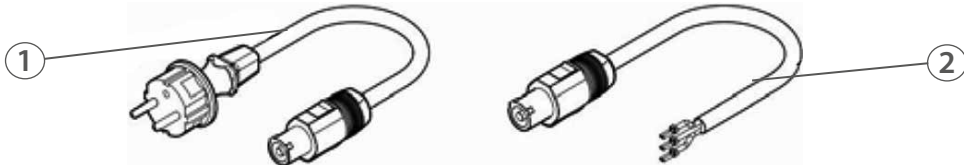
Power supply			
Voltage	Frequency	Input power	Connectors
100 —> 240 V	50-60 Hz	3 A / 625 W @ 230V 7 A / 700 W @ 100V	Neutrik powerCON TRUE1 Input : ref. NAC3PX (max. 20A)
 <ul style="list-style-type: none"> <li>• Class 1 product. <b>This luminaire must be earthed.</b></li> <li>• Must be connected directly to AC power. <b>Do not connect to dimmer power.</b></li> <li>• Automatic mains voltage detection.</li> <li>• <b>Maximum power available on output: 700 W</b></li> </ul>			

Power cable						
						
Power cable	Connector	Mains plug	Cable type	Cable length	Wiring	
1	Standard version	CEE7/7	3G1.5 H07RNF	3 m 9.8 ft	Live: Brown Neutral: Blue Ground: Yellow/Green	
2	North American version		-	14AWG SJ TYPE (UL/CSA)	1.5 m 4.9 ft	Live: Black Neutral: White Ground: Green
						

**Power ON**

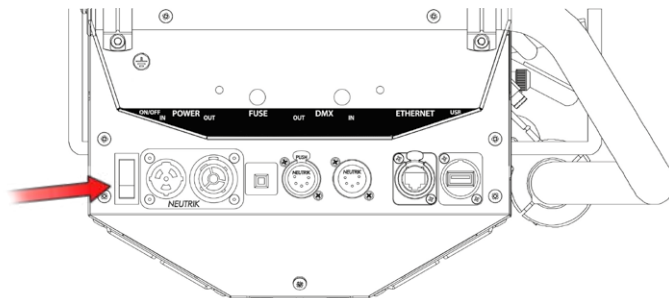

**3.3 DATA**

**3.3.1 DMX 512-A / RDM**

Protocol	Input connector	Output connector
USITT DMX 512-A RDM	XLR 5-pin	XLR 5-pin

**DATA connectors**

PIN #	DMX	Description	
1	Shielding	Foil & Braided Shield	<p>DMX OUT      DMX IN</p>
2	DMX (-)	1 <sup>st</sup> conductor of 1 <sup>st</sup> twisted pair	
3	DMX (+)	2 <sup>nd</sup> conductor of 1 <sup>st</sup> twisted pair	
4	Not used	1 <sup>st</sup> conductor of 2 <sup>nd</sup> twisted pair	
5	Not used	2 <sup>nd</sup> conductor of 2 <sup>nd</sup> twisted pair	

Daisy chain:

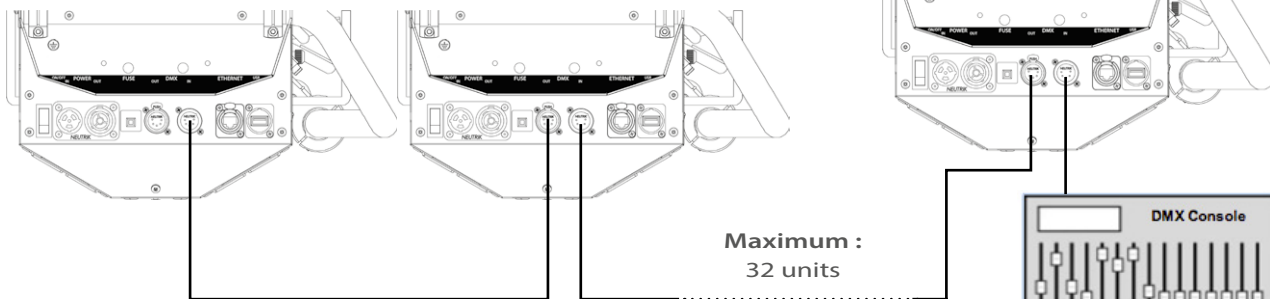

**3.3.2 Art-Net / sACN**

Protocol	Input connector	Output connector
Art-Net sACN	RJ45	-

Daisy chain:

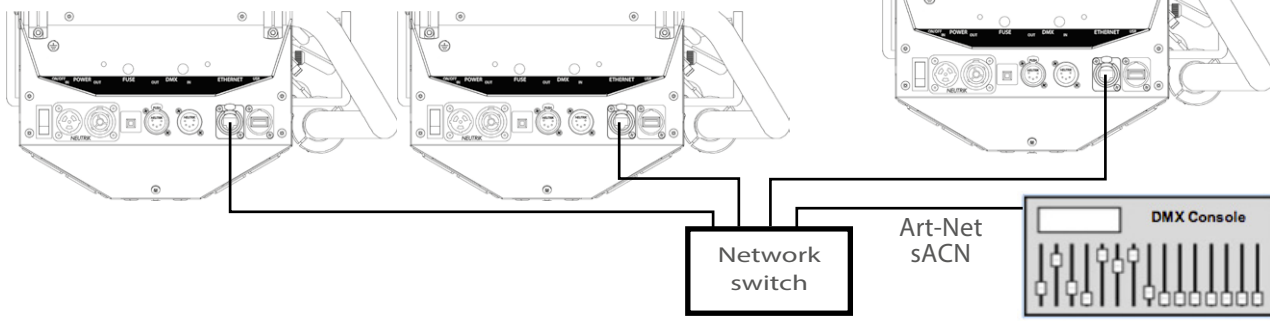

3.3.3 Ethernet / DMX node

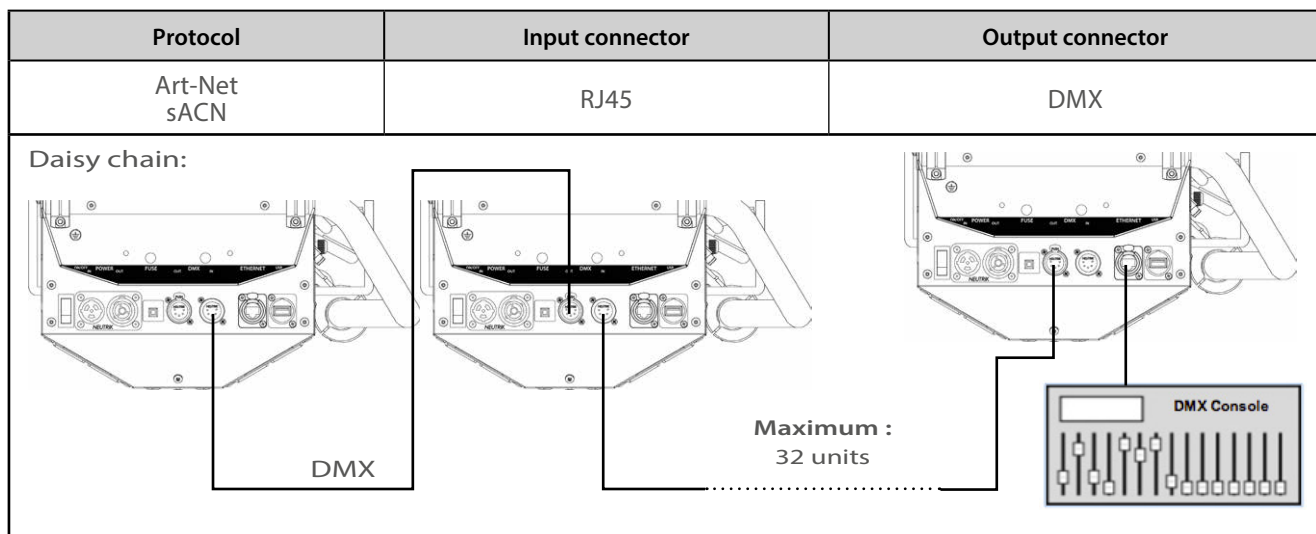

3.3.4 Wireless DMX available soon.

3.4.1 Full closing iris cassette

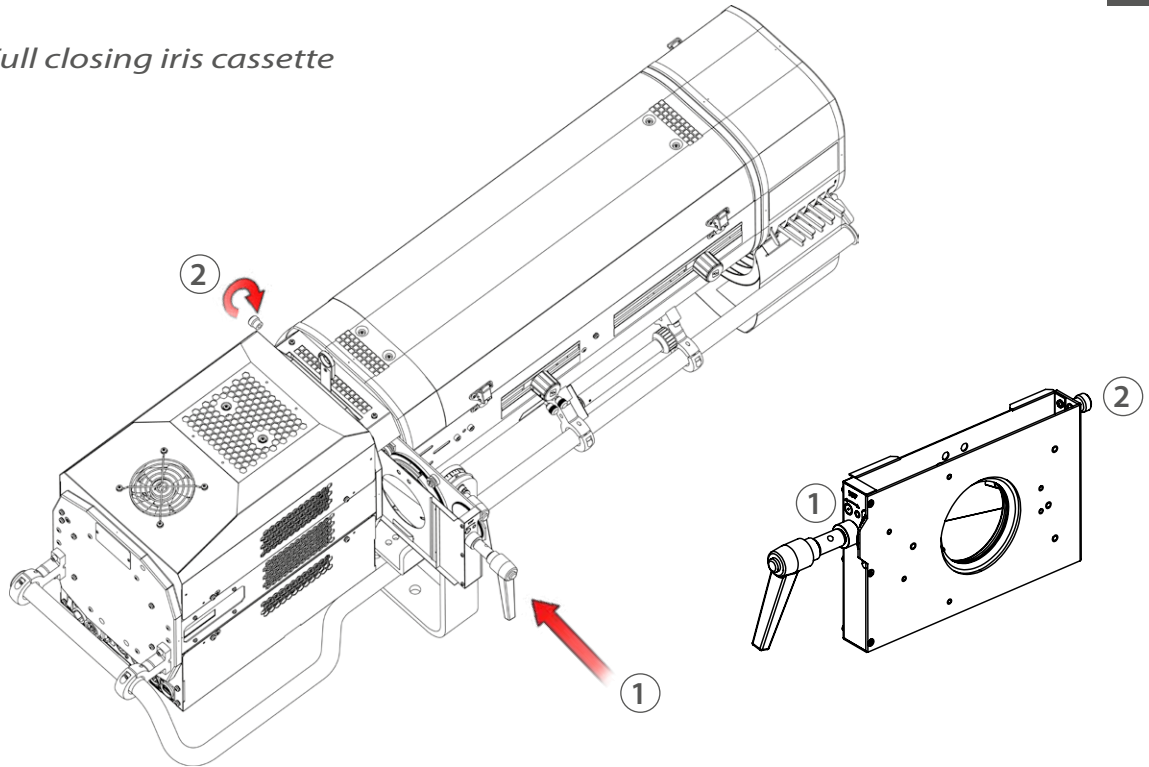

3.4.2 Colour changer unit - boomerang (only available for OZ)

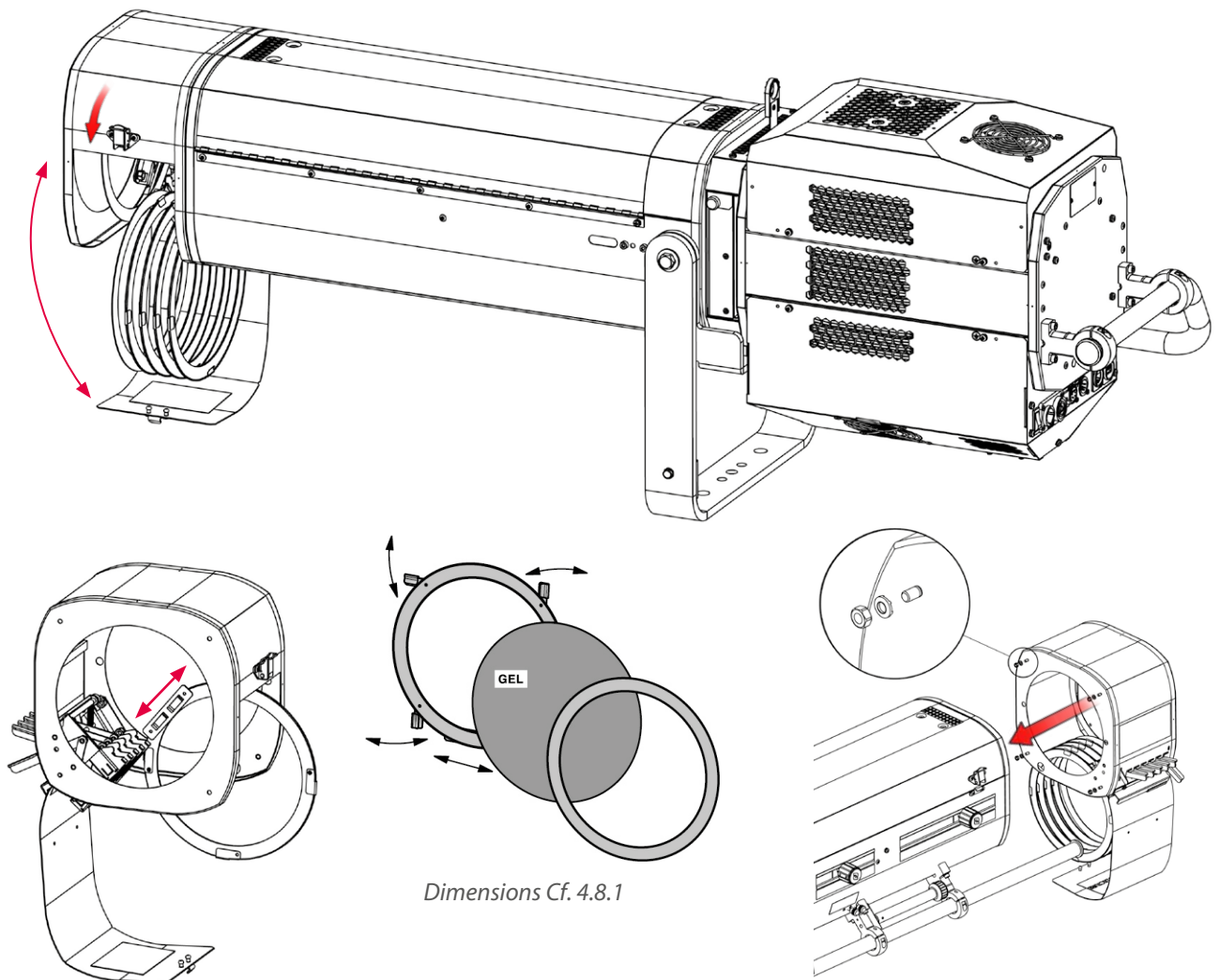

3.4.3 Colour changer unit - push-pull (ALICE)

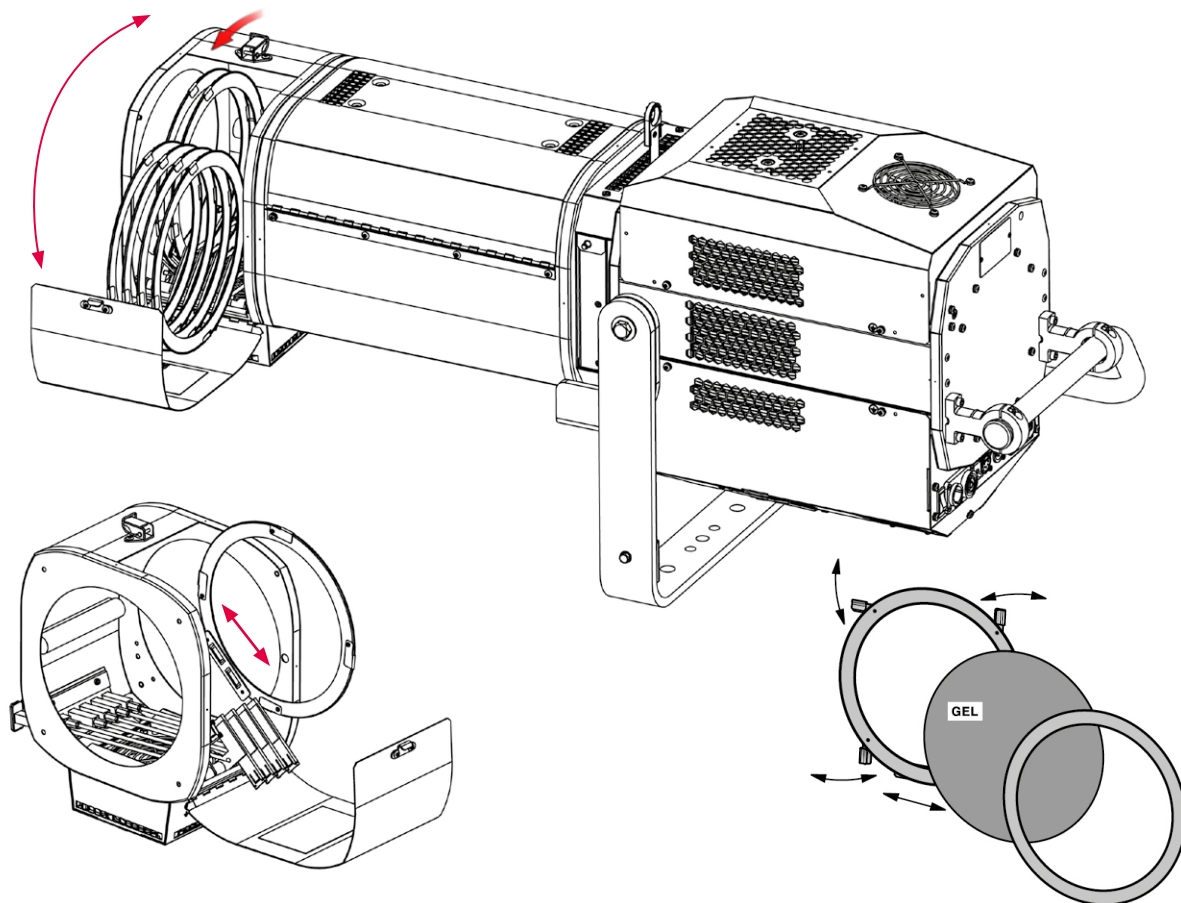

Dimensions Cf. 4.8.1

3.4.4 Gobo holder

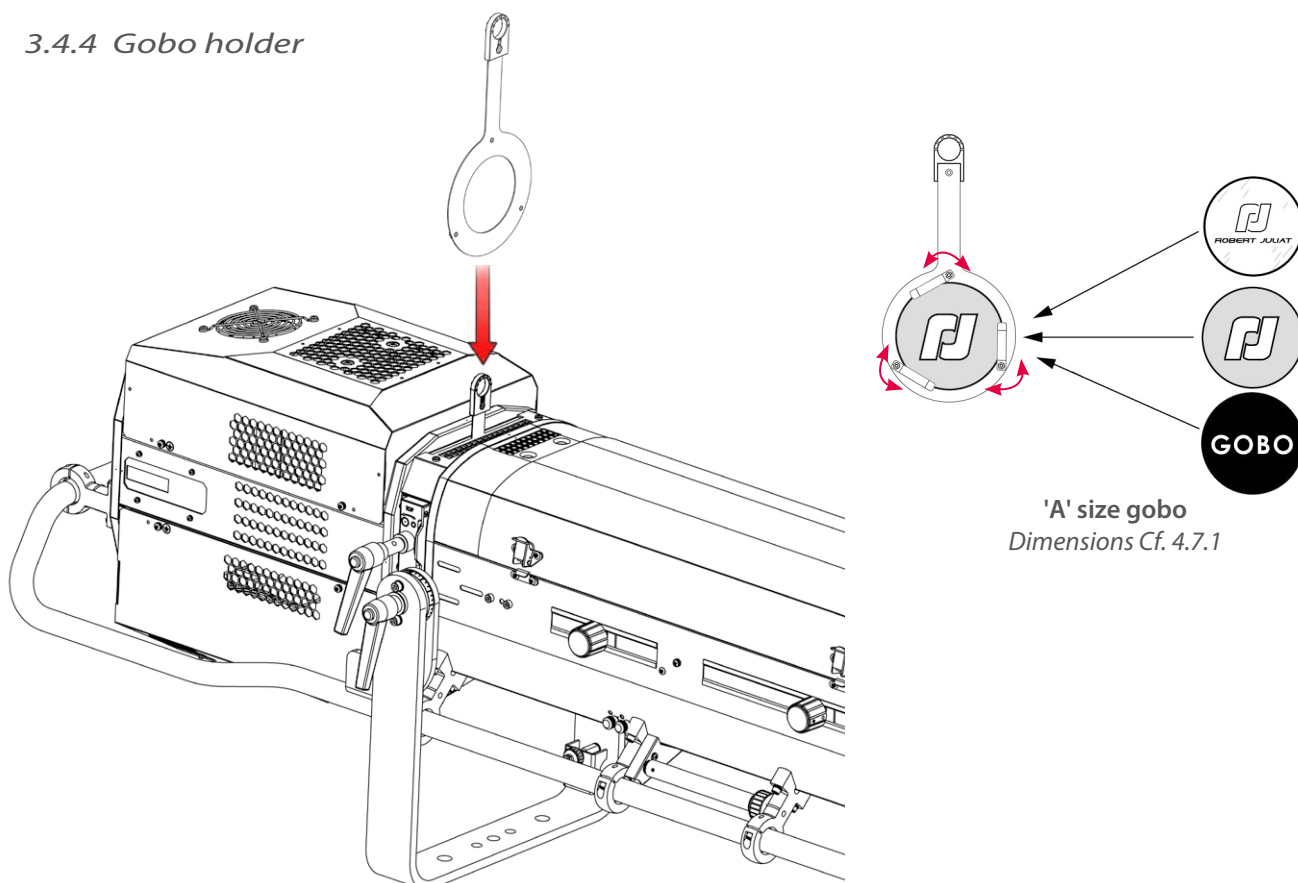

'A' size gobo  
Dimensions Cf. 4.7.1

3.4.5 Double slot front cassette for 215 x 215 mm accessories (option)

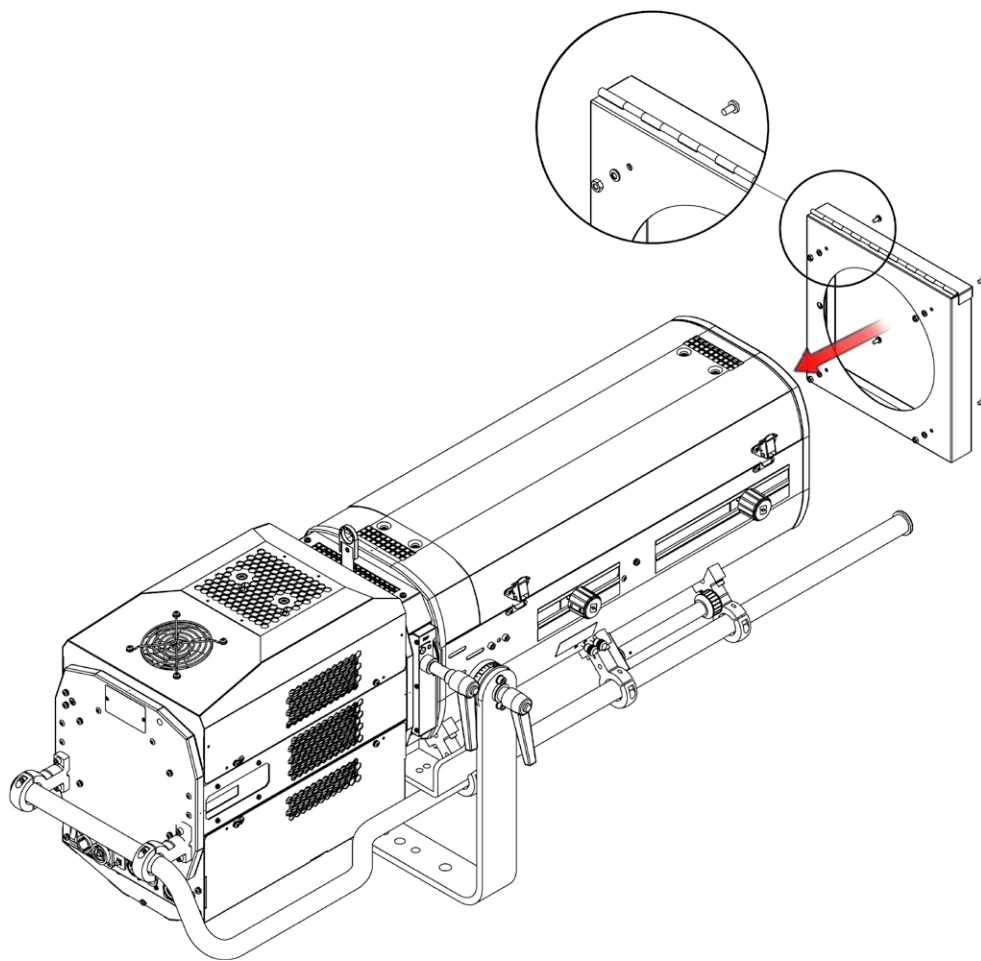

3.4.6 Frosted / CTO glass (option)

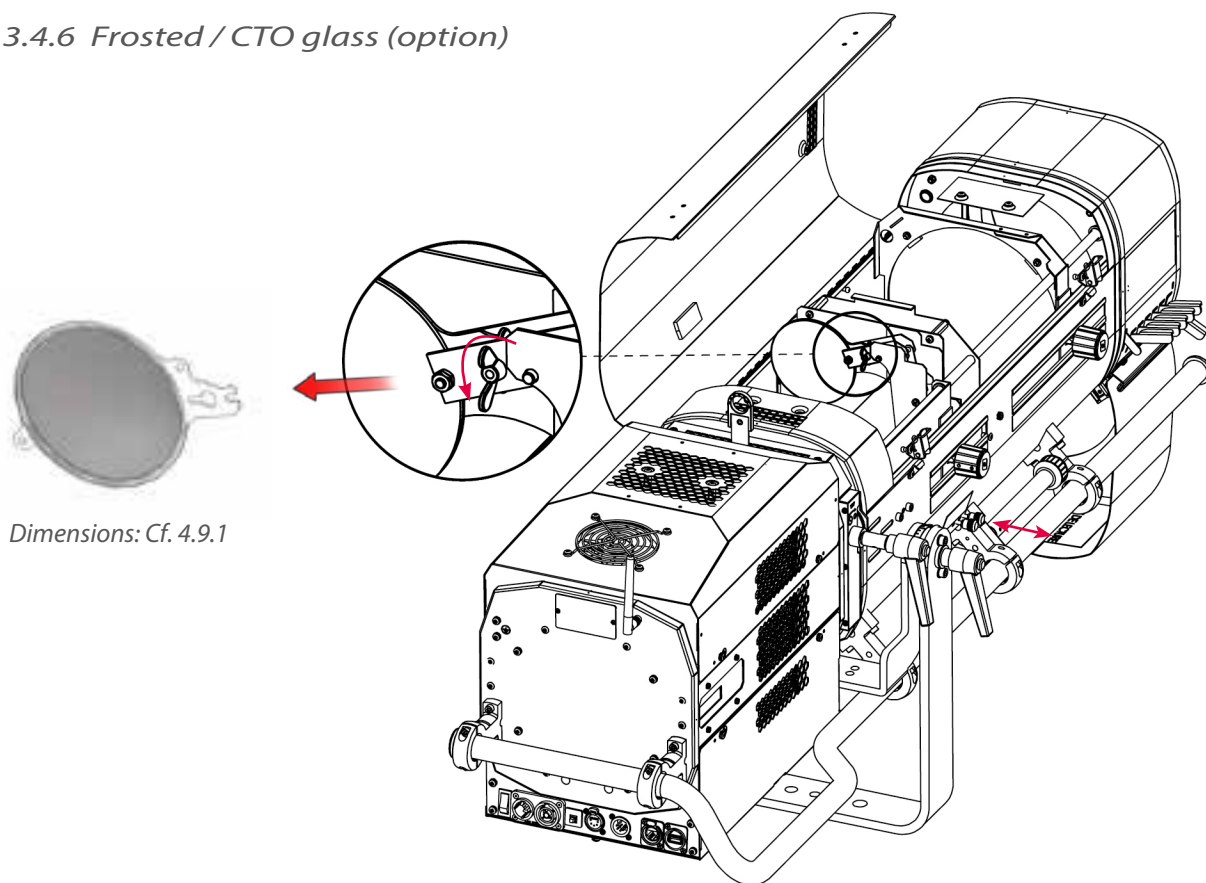

3.4.7 Internal glass holder 120 x 120 mm (option)

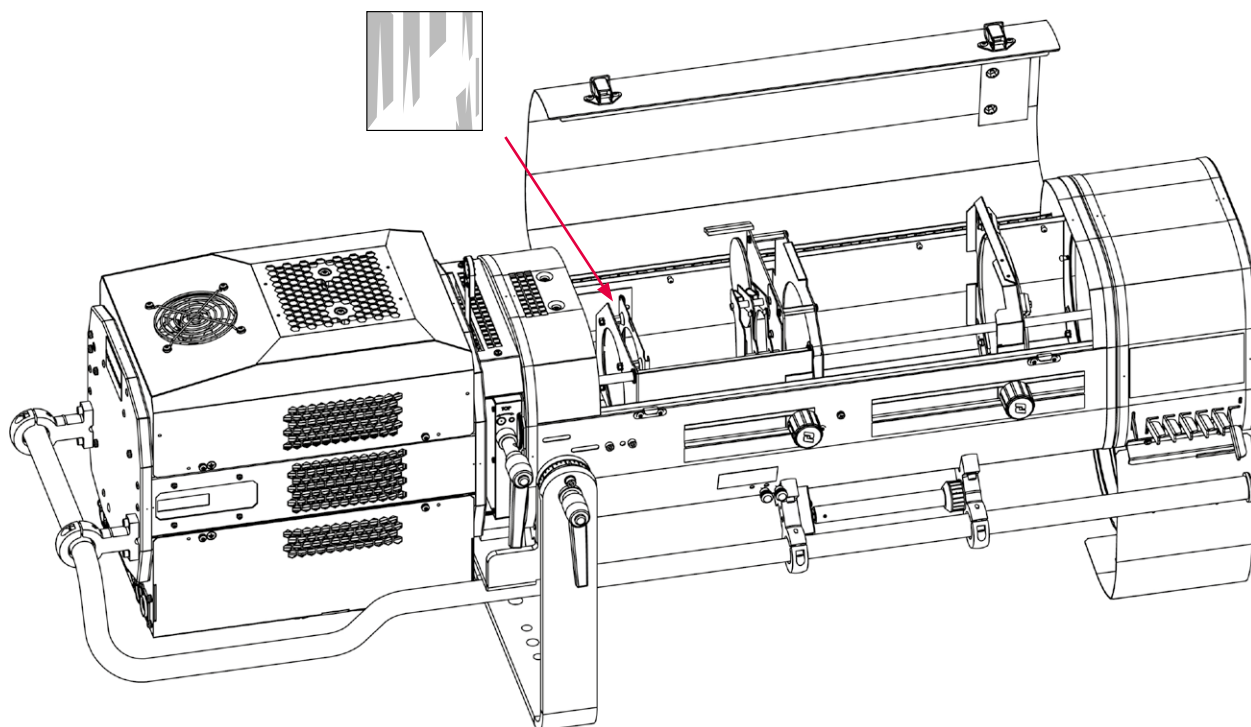

3.4.8 Horizontal chopper (option)

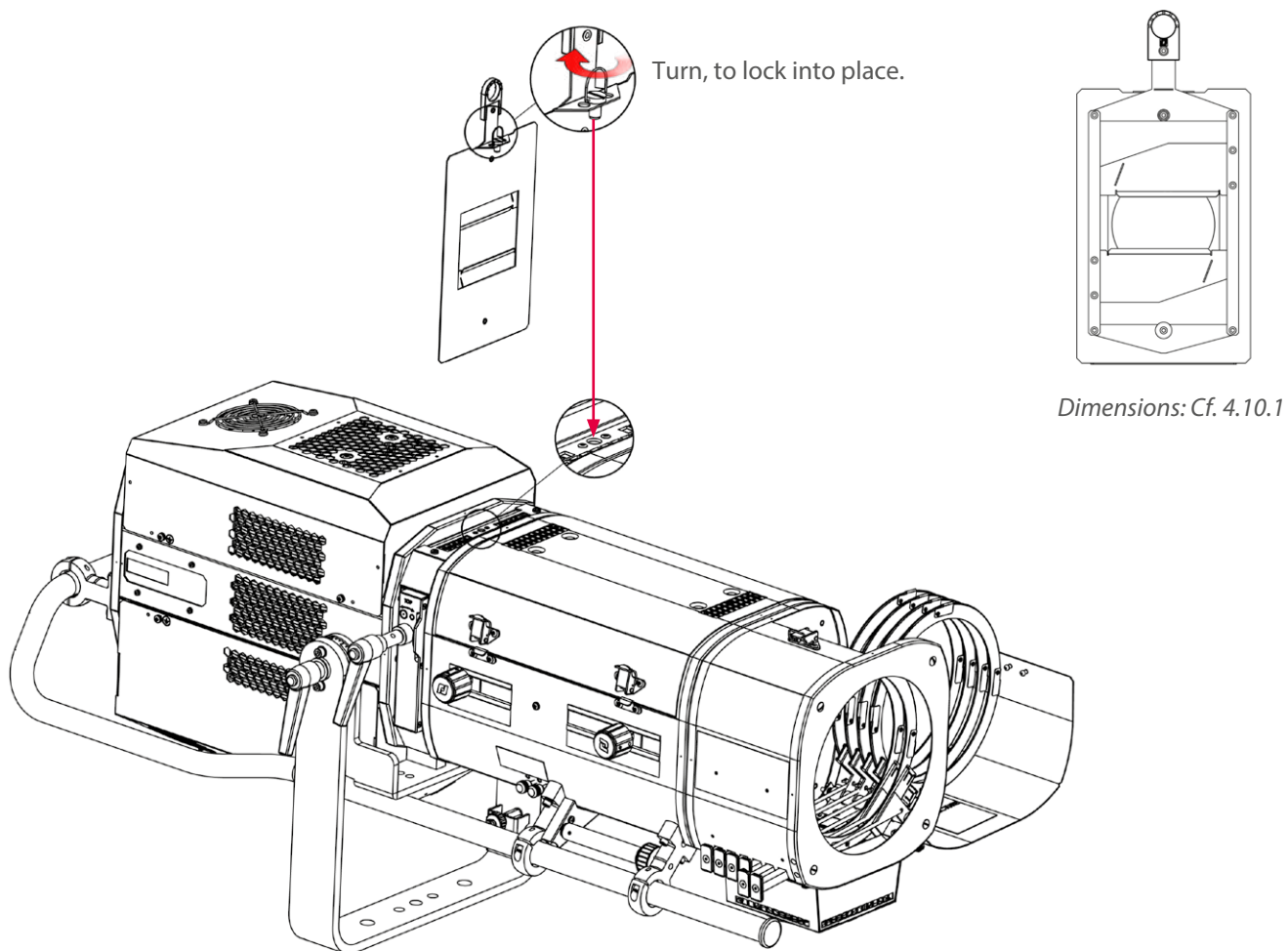

### 3.4.9 Stands

• GT4000 Series : Please refer to the relevant stand technical files for further details.

Stand set-up, refer to Cf. 3.1.5.

### 3.4.10 Heavy duty adjustable yoke (option)

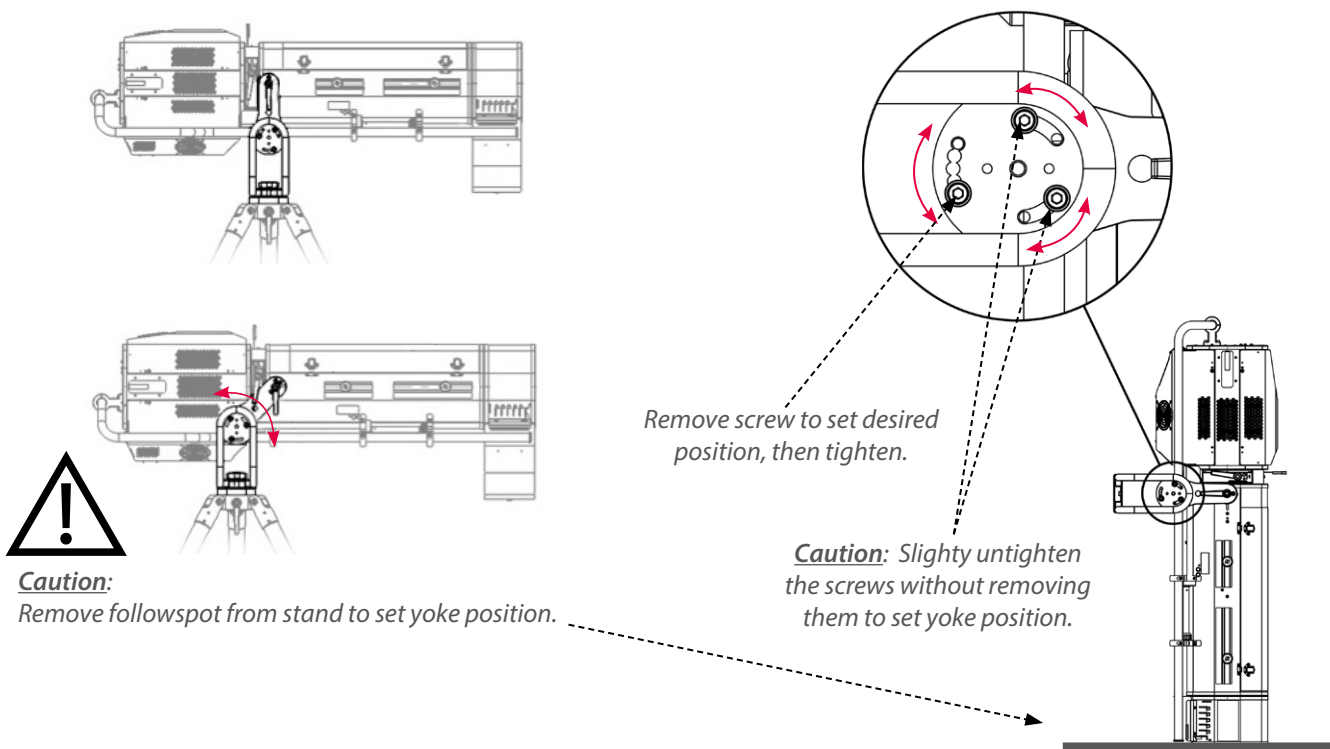

### 3.4.11 Telrad followspot sight (option)

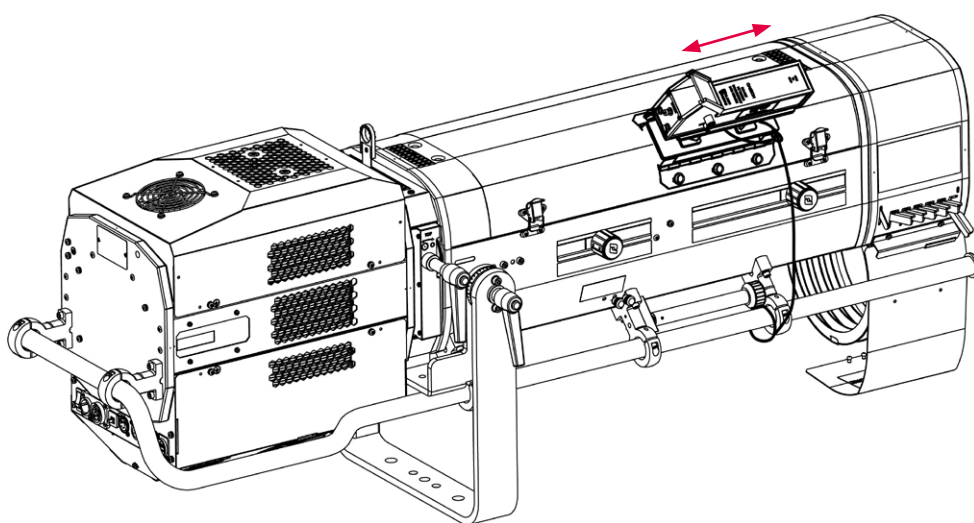

Followspot sight guide available @ [www.robertjuliati.com/followspots/Accessories.html](http://www.robertjuliati.com/followspots/Accessories.html)

**Caution:** - Do not install the followspot sight on the lamp house to avoid blocking the ventilation vents.  
 - Secure the sight with a suitable safety cable.

### 3.4.12 Flight-case (option)

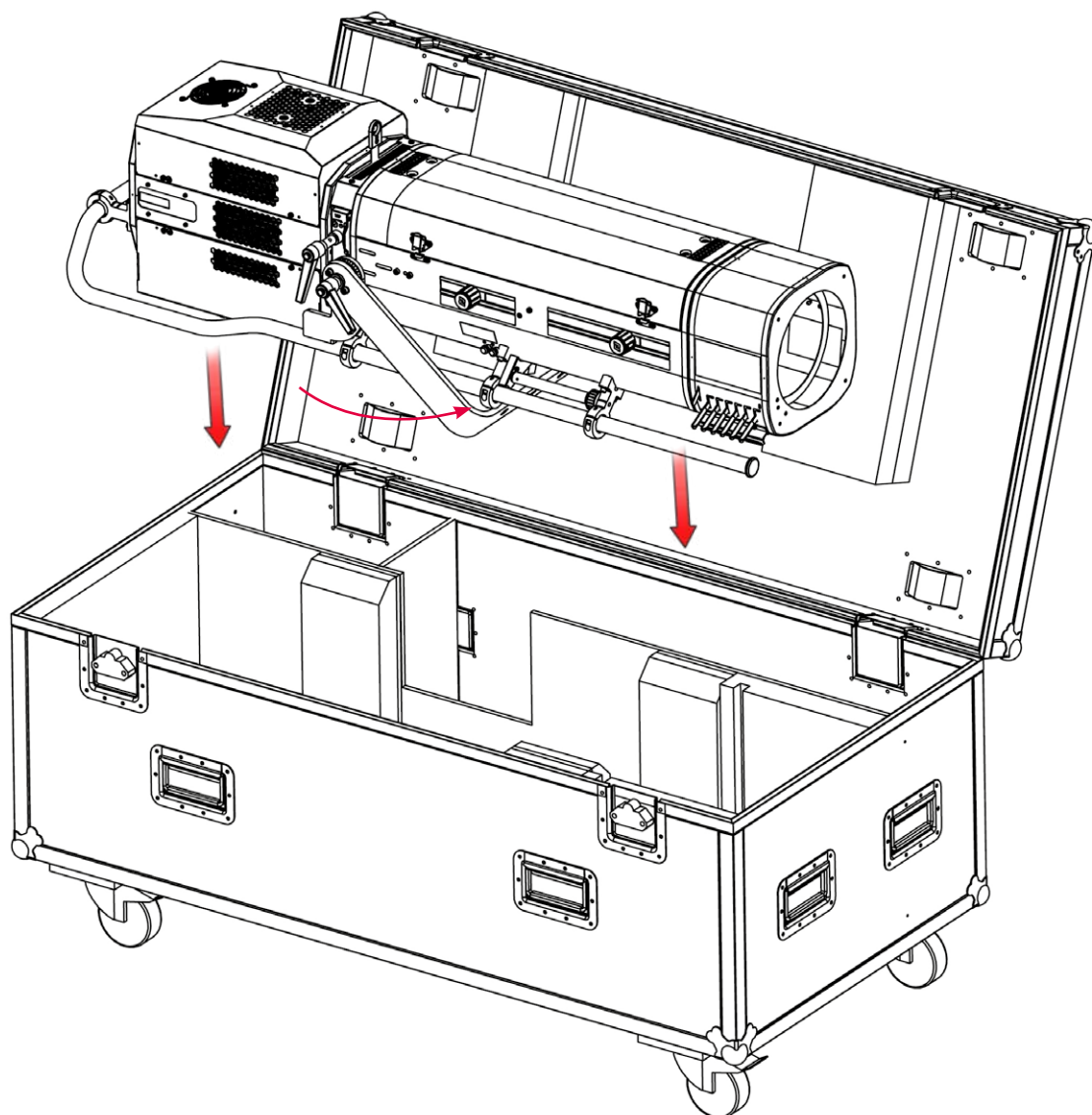

## 4.1 Light intensity

### 4.1.1 Range

• Dimming

0%



100%

### 4.1.2 Control

Remotely with DMX512-A protocol

Locally via rotary knob

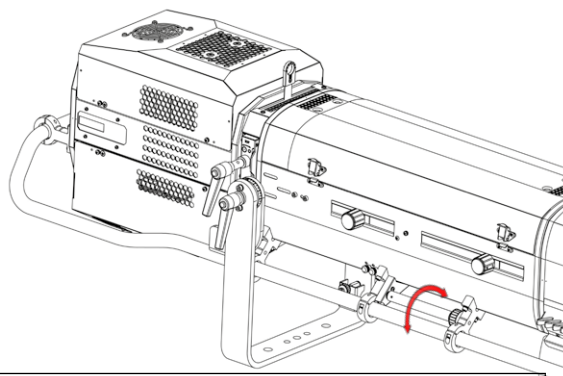
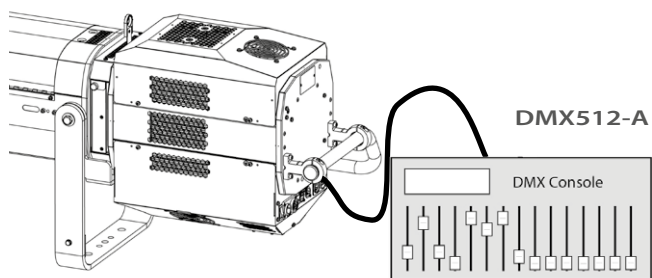

**HTP mode (Highest Takes Precedence):**  
Light output is the highest value of DMX512 command or local control

**Focus mode:** when standby screen displayed,  
Push Exit for 3 secs → Light output = 100% for 1 minute  
2x times Exit → Light output = 0%

### 4.1.3 Parameters

#### 4.1.3.1 Dimming resolution - DMX only

Resolution	DMX mode
8 bits – 255 steps	2 - 4 - 6
16 bits – 65 535 steps	1 - 3 - 5

#### 4.1.3.2 Dimming curve

→ selection in SETUP/DIMMER/CURVE menu: LINEAR or SQUARE

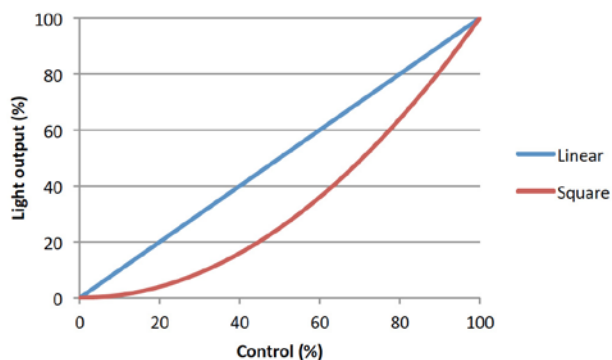

### 4.1.3.3 Master control

In order to supervise the operator from the console, master control DMX channel can be used. This channel limits the maximum value of the dimmer shutter. By using this function, it is possible to obtain synchronised fades with several spots or to give intensity limits (minimum and maximum) to the operator. Master is only active when DMX is detected.

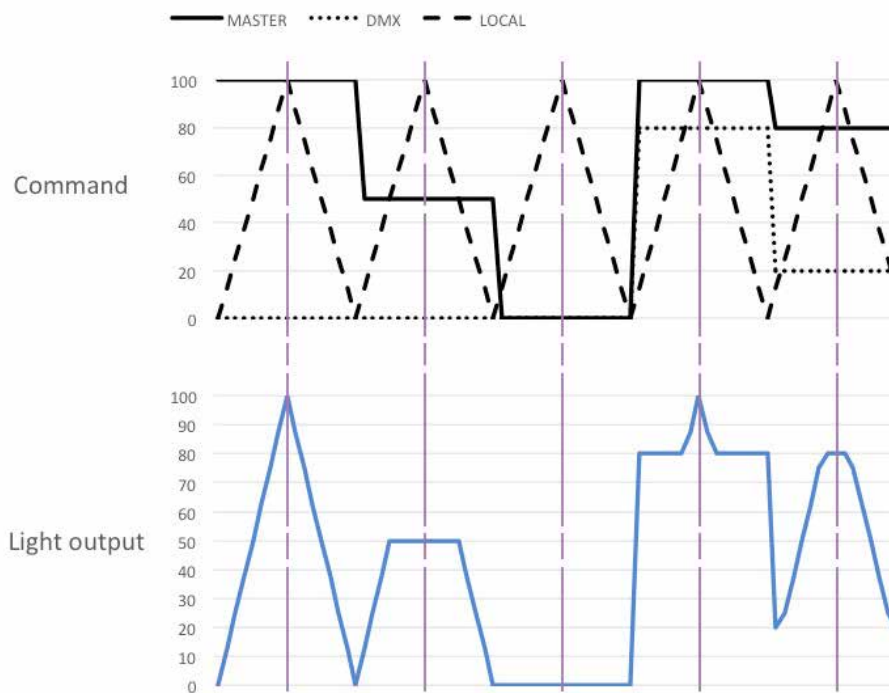

### 4.1.3.4 Set maximum position

→ Selection in *SETUP/DIMMER/SET MAX POSITION* menu

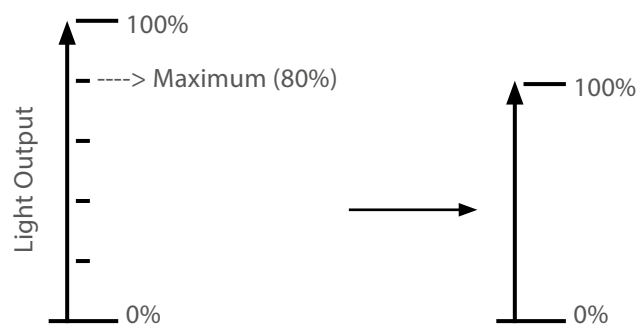

### 4.1.3.5 Sensitivity available soon.

## 4.2 Strobe

### 4.2.1 Range

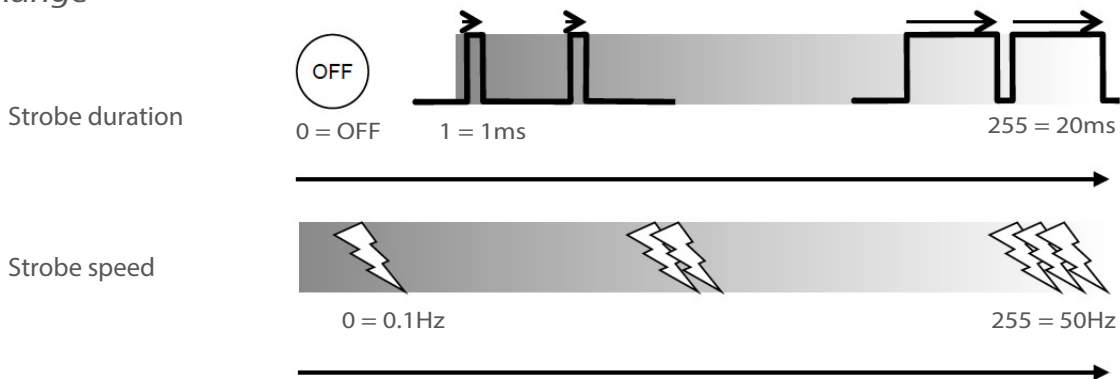

### 4.2.2 Control

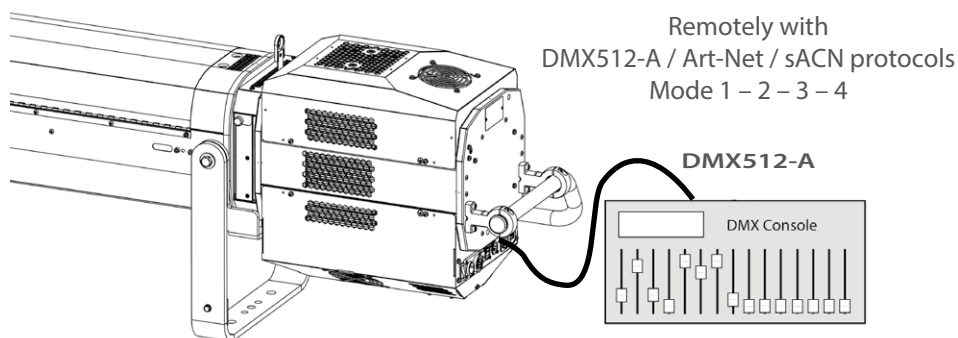

## 4.3 Response time

### 4.3.1 Range

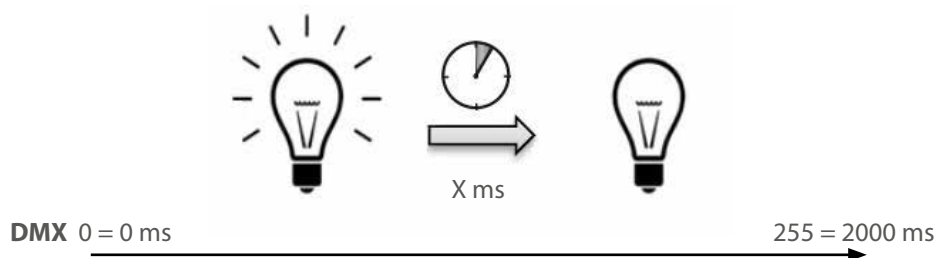

### 4.3.2 Control

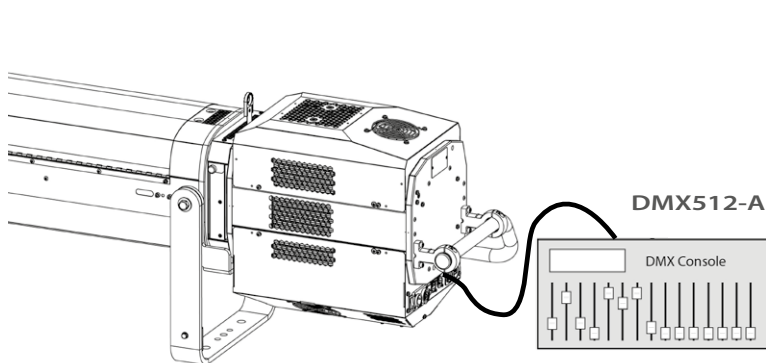

Remotely, with DMX512-A / Art-Net / sACN protocols Mode 1 - 2 - 3 - 4

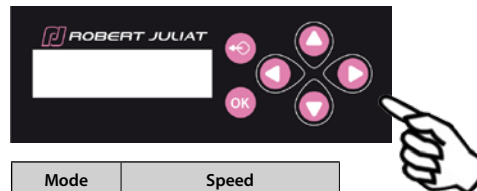

Mode	Speed
NONE	OFF
SLOW	1000 ms
MEDIUM	600 ms
FAST	300 ms
CUSTOM	0 - 2000 ms

Locally, only when no DMX detected → selection in SETUP/DIMMER/RESPONSE TIME

### 4.4 Beam size adjustment

#### 4.4.1 Range

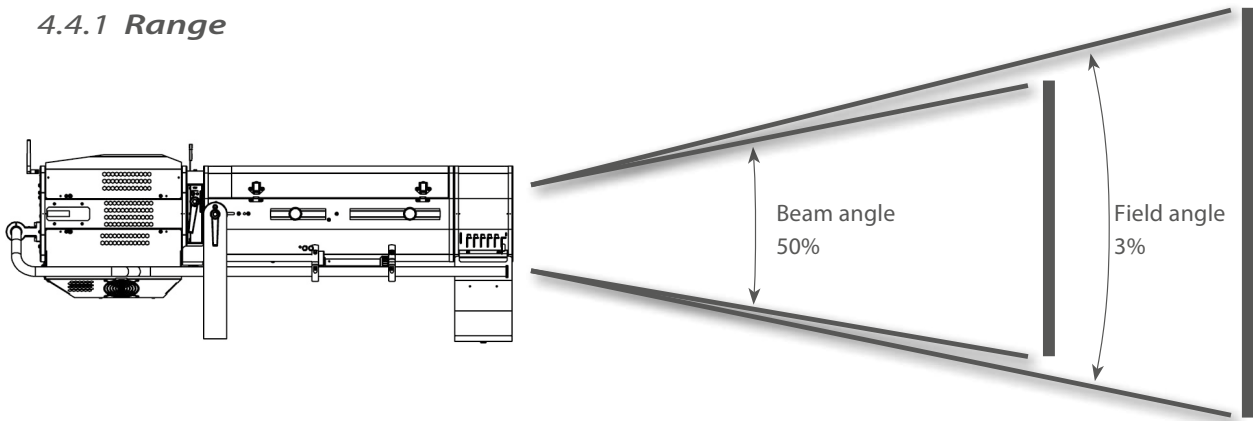

Model	Angles	Minimum angle	Maximum angle
OZ 1169	Beam angle	6.9°	13.4°
	Field angle	7.1°	13.8°

Model	Angles	Minimum angle	Maximum angle
ALICE 1469	Beam angle	12.9°	20.6°
	Field angle	13.2°	21.1°

#### 4.4.2 Control

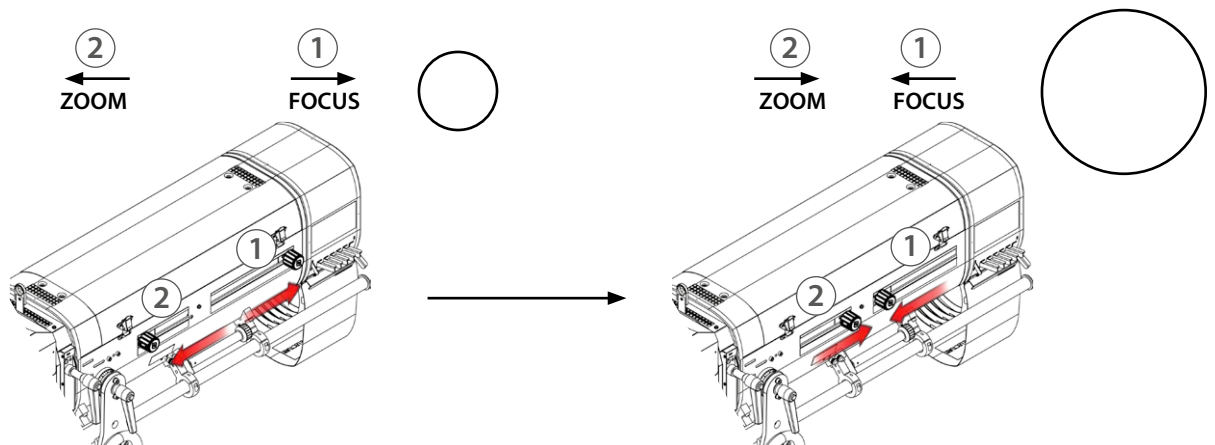

4.5 Pan / Tilt

4.5.1 Range

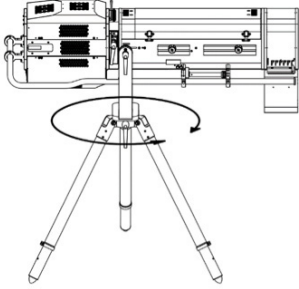
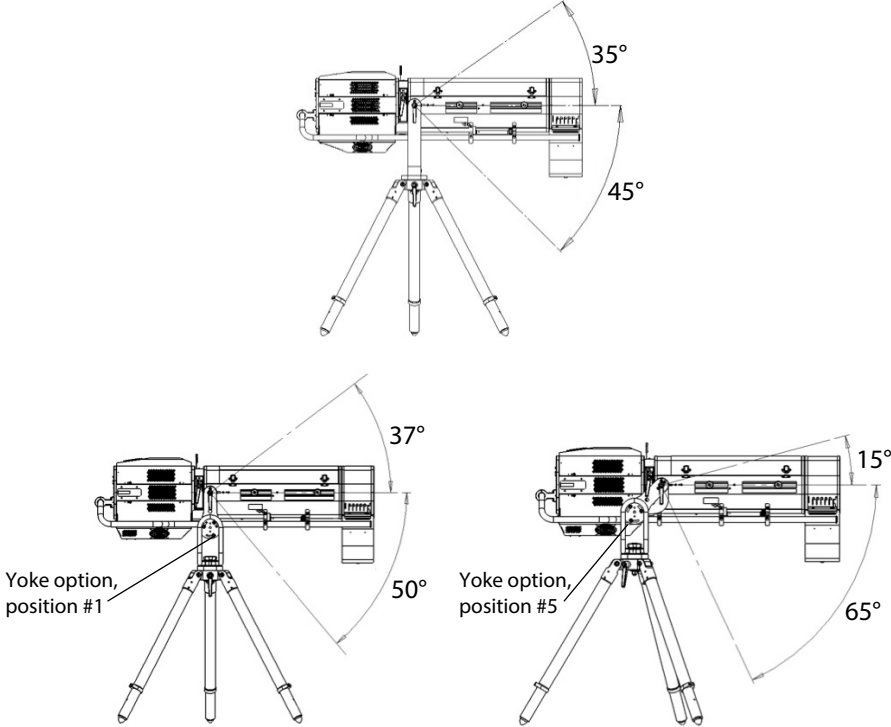
Function	Range
<p style="text-align: center;"><b>PAN</b></p> 	<p style="text-align: center;">0 → 360°</p>
<p style="text-align: center;"><b>TILT</b></p> 	

4.5.2 Control

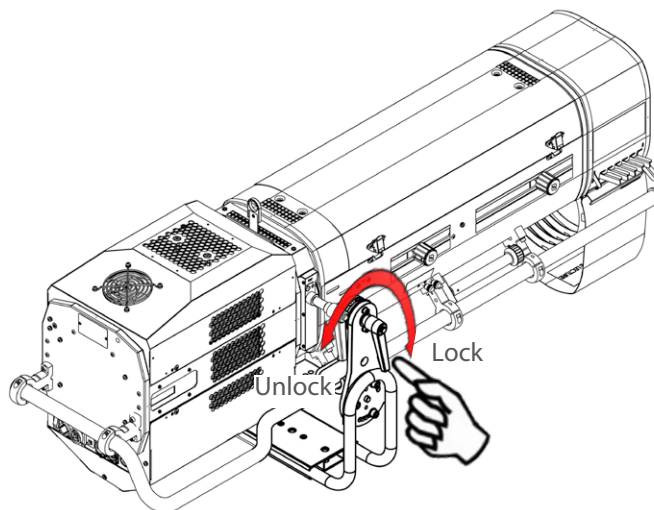

4.6 Iris

4.6.1 Range

- Irising

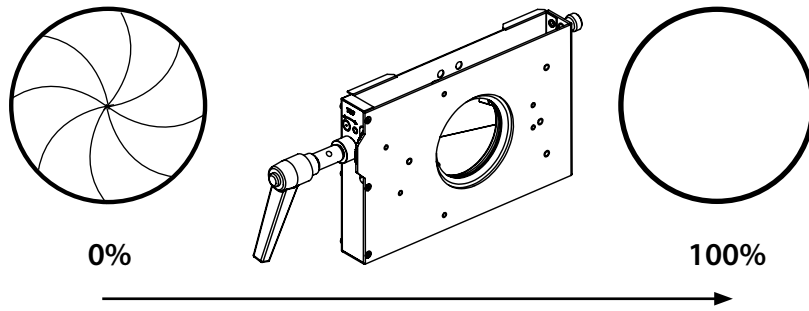

4.6.2 Control

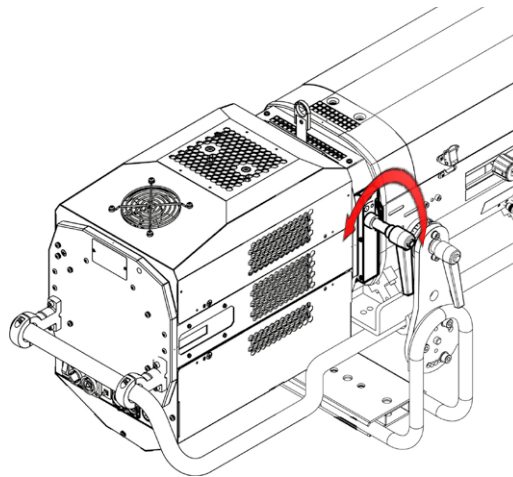

4.7 Gobo

4.7.1 Range

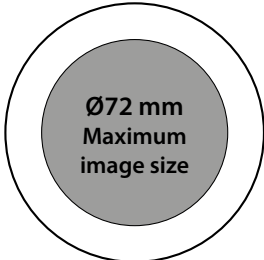
Type	Standard gobo - A size	
Dimensions	<p style="text-align: center;"><b>Ø100 mm</b></p> 	<ul style="list-style-type: none"> <li>• Metal</li> <li>• Glass</li> </ul>
Installation	Cf. section: 3.4.4	

4.7.2 Control

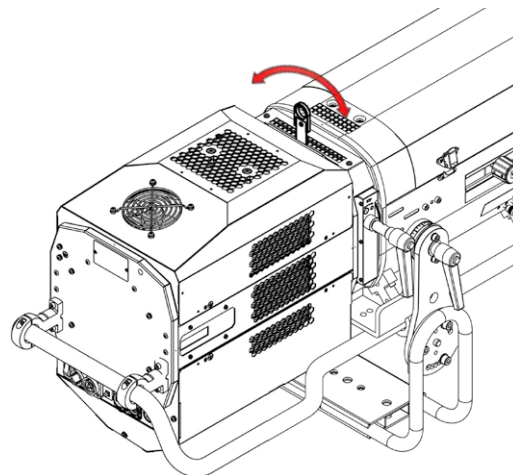

4.8.1 Range

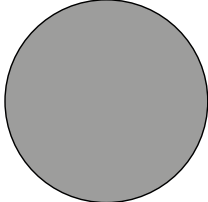
Type	Coloured gel filter
Dimension	<p>Ø210 mm</p> 
Installation	<p>Cf. section: 3.4.2 &amp; section 3.4.3 Place dark colours towards the front end.</p>

4.8.2 Control

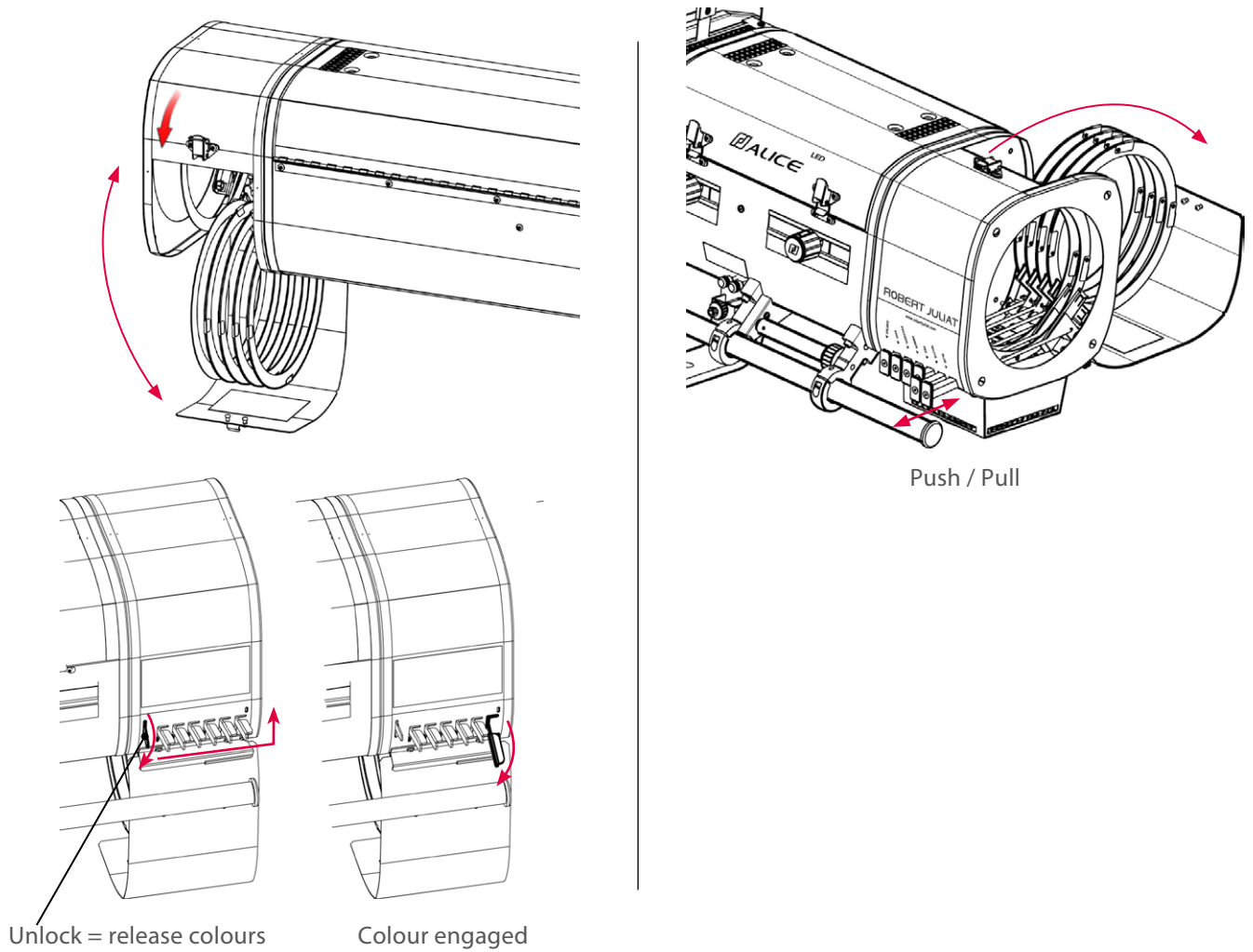

4.9.1 Range

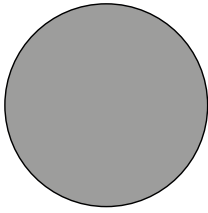
Type	Frost or CTO glass
Dimension	<p style="text-align: center;"><b>Ø97 mm</b></p> 
Installation	Cf. section: 3.4.6

4.9.2 Control

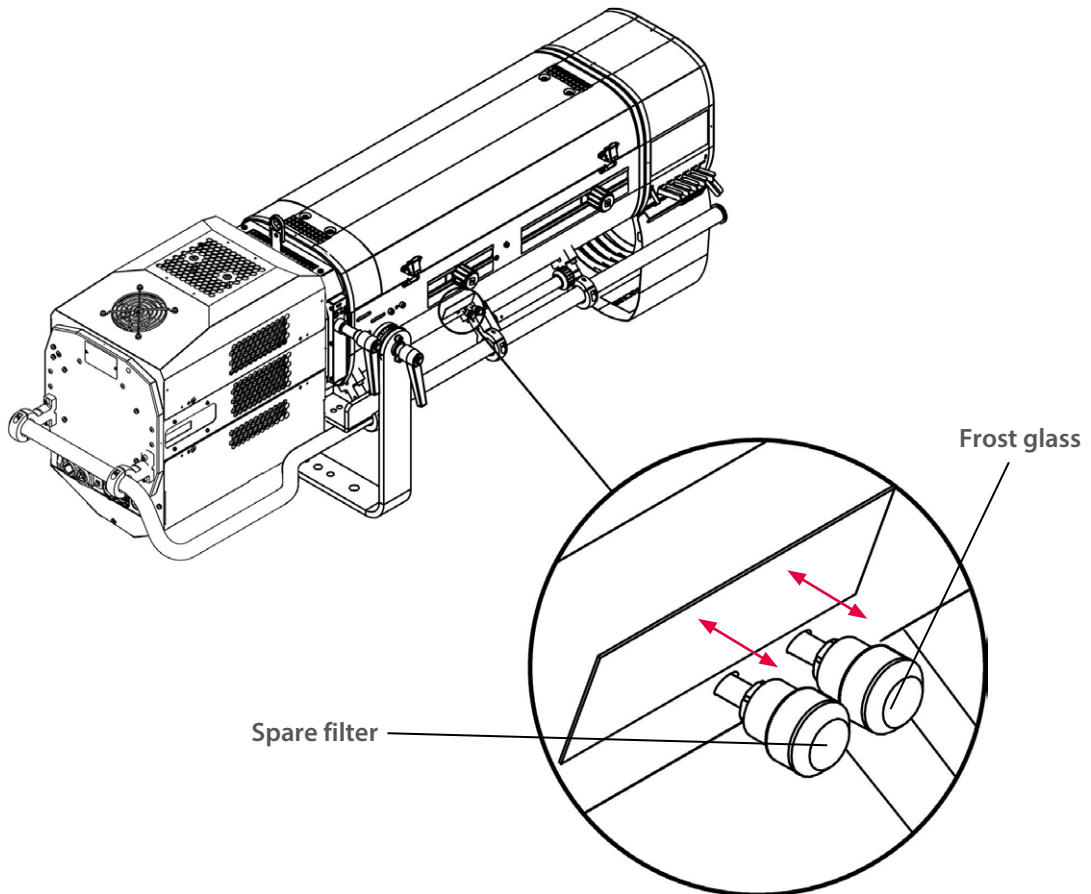

## 4.10 Horizontal chopper

### 4.10.1 Range

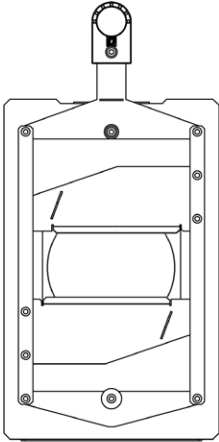
Type	Accessory option: PG80 chopper kit
Dimension	 Ø80 mm
Installation	Cf. section: 3.4.8

### 4.10.2 Control

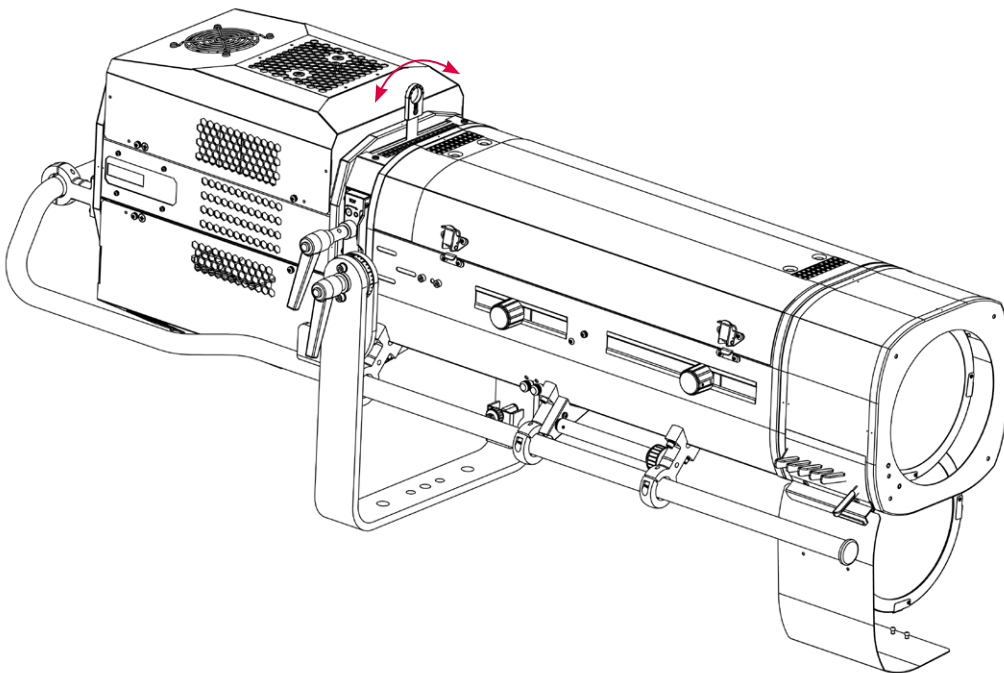





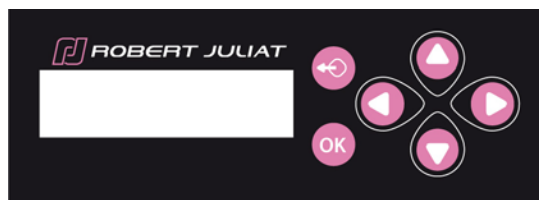

# 5 Controls and parameters

## 5.1 Local display and controls

### 5.1.1 Display



Function	
	Exit the current menu option and/or go back
	Press for 3 secs to enter Focus mode
	Enter the current menu option and/or valid
	Scroll through menus and/or Increase data value
	Scroll through menus and/or Decrease data value
	Scroll through menus and/or Increase data value
	Scroll through menus and/or Decrease data value

### 5.1.2 Menu

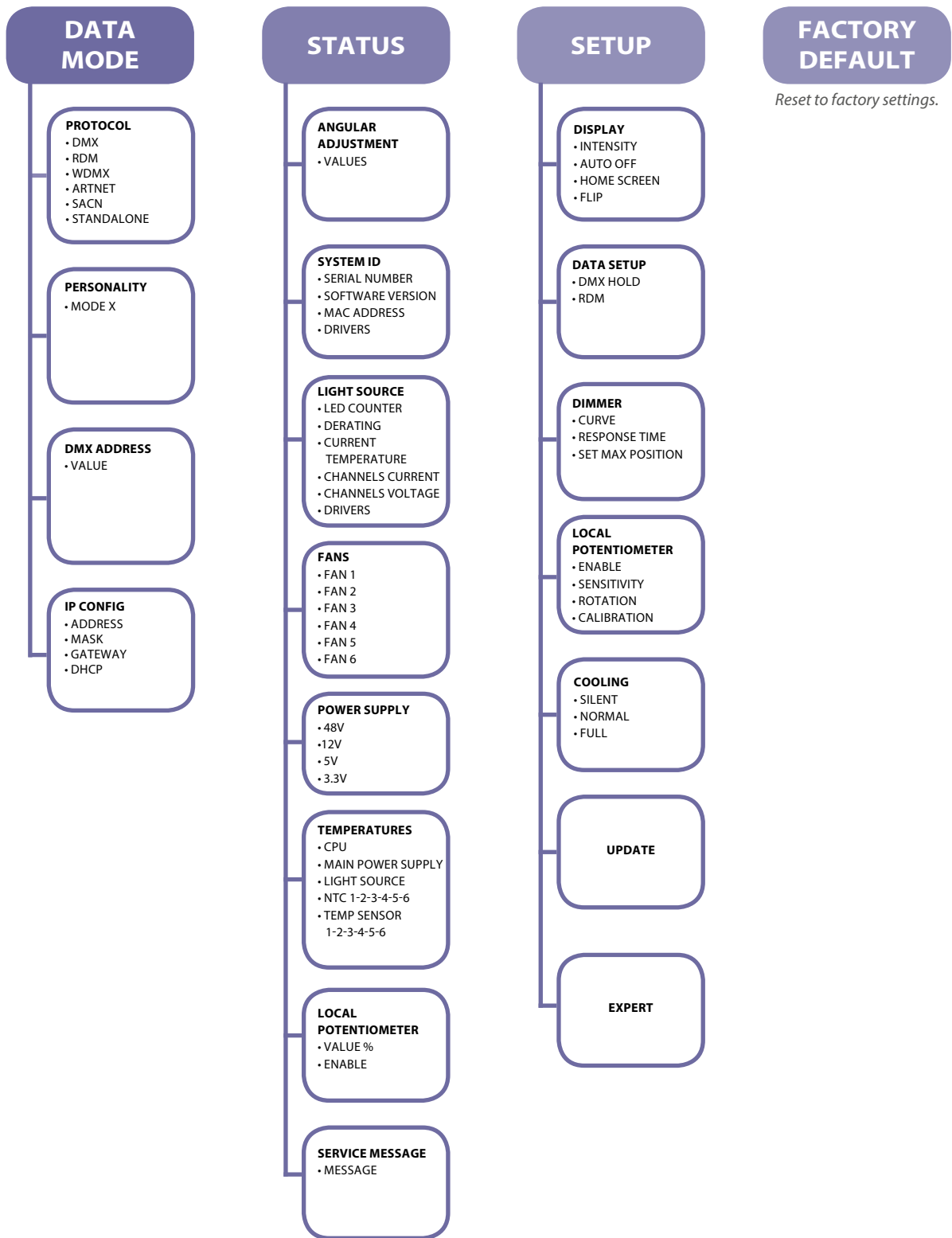

→ Selection in *SETUP/DISPLAY MODE* menu

Display	Mode	Description
	Always ON	Main display (home screen) always ON
	Intensity	Adjust the intensity of the screen <i>To change value, press buttons :</i> press OK to validate
	Auto-OFF	Main display OFF after 20 seconds
	Home Screen	A choice between 2 screen displays, Mode 1 & Mode 2 <i>To change value, press buttons :</i> press OK to validate
	Flip	AUTO : Will change automatically NORMAL : Screen display horizontally FLIP : Change to vertical display <i>To change value, press buttons :</i> press OK to validate

## 5.2 DMX512 - A remote control

### 5.2.1 Protocol:

#### E1.11 – 2008, USITT DMX512-A

### 5.2.2 Configuration:

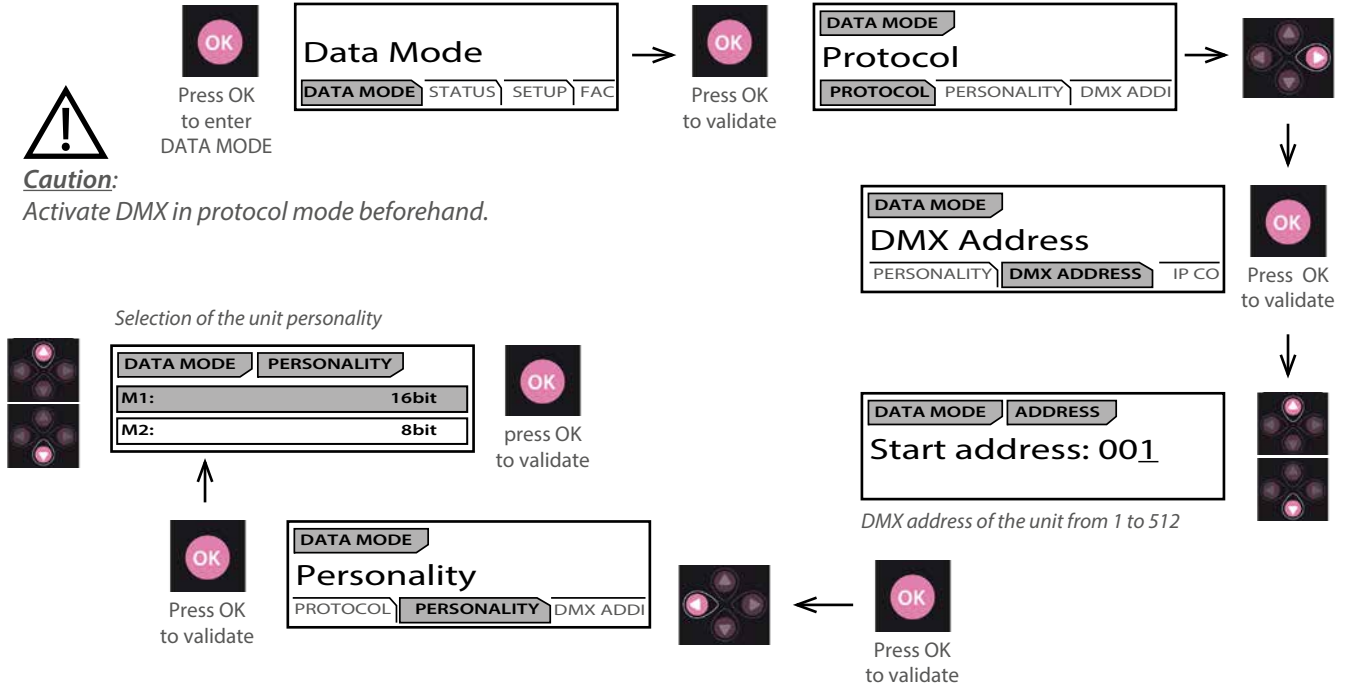

### 5.2.3 Parameters:

#### 5.2.3.1 DMX Hold

→ Selection in SETUP/DMX HOLD menu

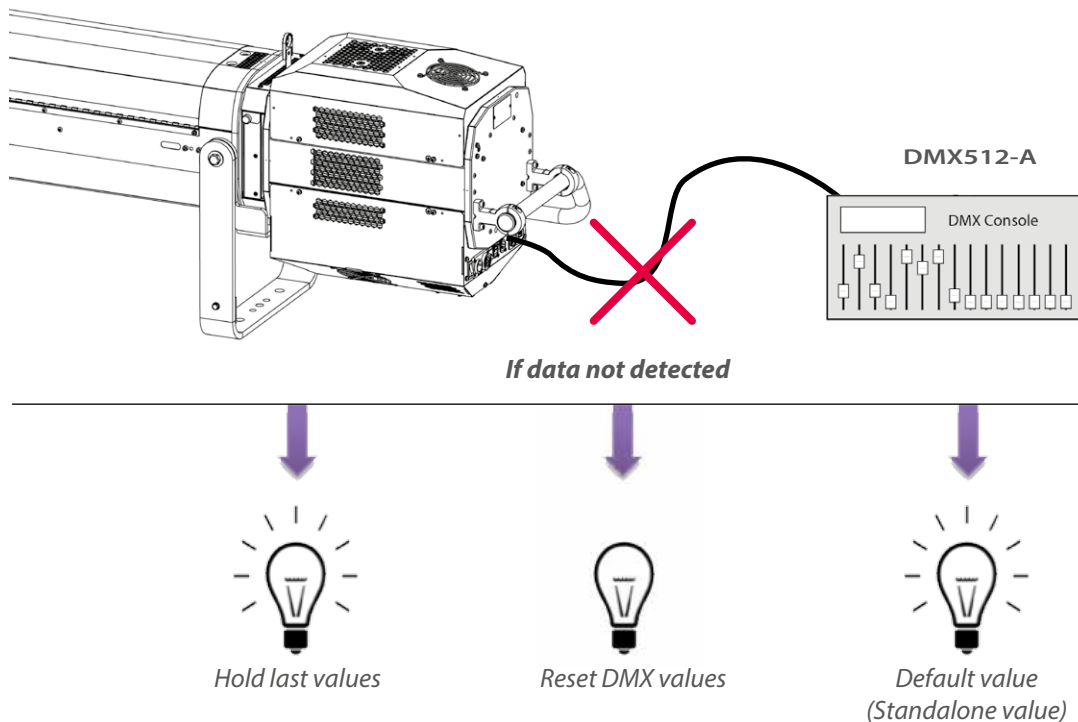

### 5.2.4 DMX chart:

DMX address	Mode 1: Followspot16b	Mode 2: Followspot8b	Mode 3: Profile16b	Mode 4: Profile8B	Mode 5: Dimmer16B	Mode 6: Dimmer8B
1					Dimmer	Dimmer
2					Dimmer fine	
3						
4						
5						
6						
7						
8						

Coming soon...

### 5.2.5 DMX ranges:

#### 5.2.5.1 Strobe duration

Range min	Range max	Function
0	0	Strobe OFF
1	255	Strobe ON - 1 ms → 20 ms

#### 5.2.5.2 Strobe speed

Range min	Range max	Function
0	255	Frequency: 0,1 Hz → 50 Hz

#### 5.2.5.3 Response time

Range min	Range max	Function
0	250	Dimmer timing: 0 ms → 200 ms
251	255	OFF

#### 5.2.5.4 Control mode

Range min	Range max	Function
0	0	
1	10	RDM disabled
11	20	RDM enabled
21	100	not used
101	110	Cooling mode: Silent
111	120	Cooling mode: Normal
121	130	Cooling mode: Full power
131	255	not used

Function activated after 5 seconds - need to go back to zero to activate second function.

### **5.3 RDM remote control**

#### **5.3.1 Protocol: ANSI E1.20 – 2010 / ANSI E1.37 - 1**

For more information about RDM protocol: <http://www.rdmprotocol.org/>

#### **5.3.2 Functions: available soon.**

#### **5.3.3 Parameters ON/OFF: available soon.**

5.4.1 Protocol: Artistic Licence Art-Net

For more information about Art-Net protocol: <http://art-net.org.uk/>

5.4.2 Configuration:



**Caution:**

Activate Art-Net in protocol mode beforehand.

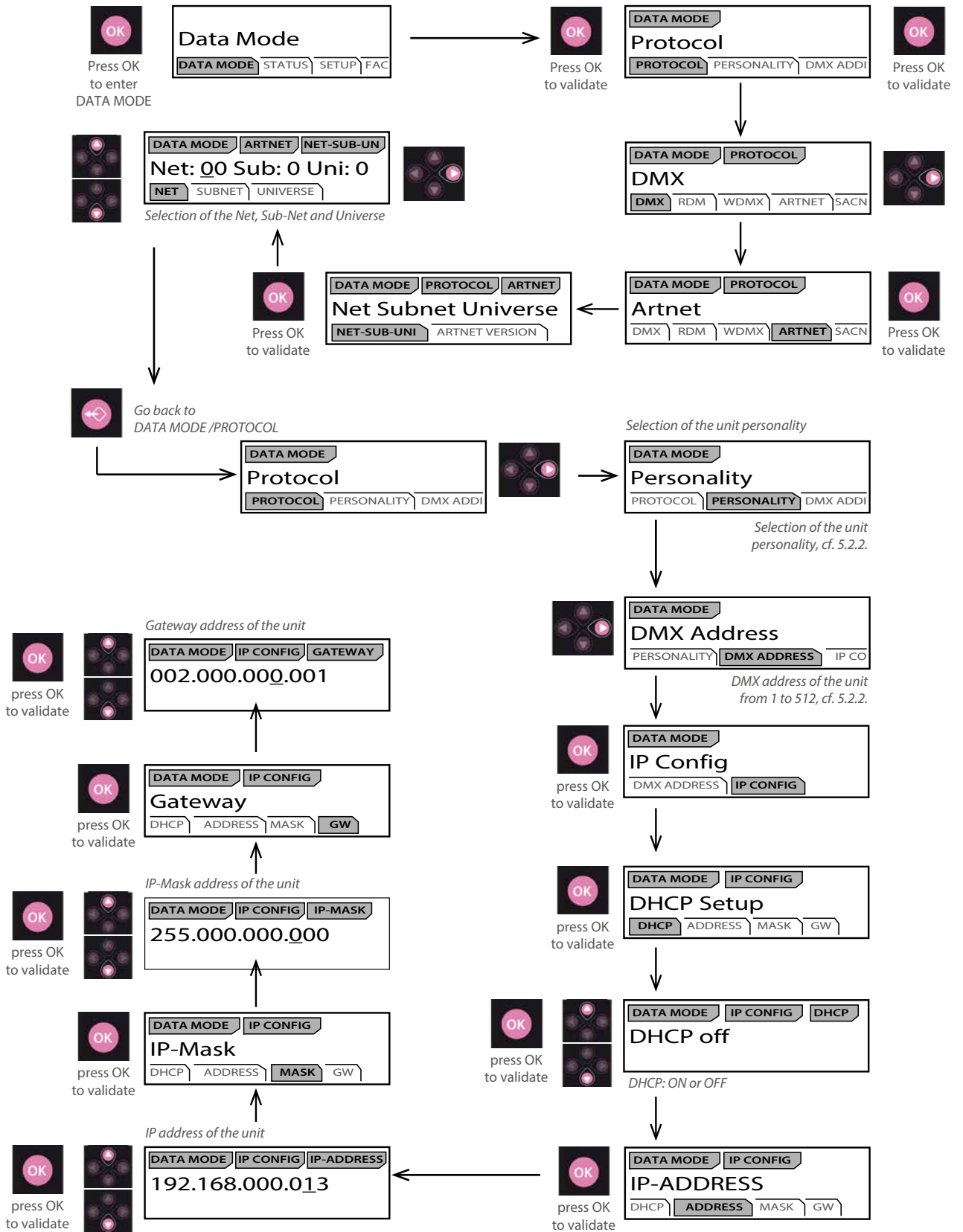

## 5.5 sACN remote control

### 5.5.1 Protocol: ANSI E1.31 – 2009 sACN (Streaming-ACN)

### 5.5.2 Configuration:





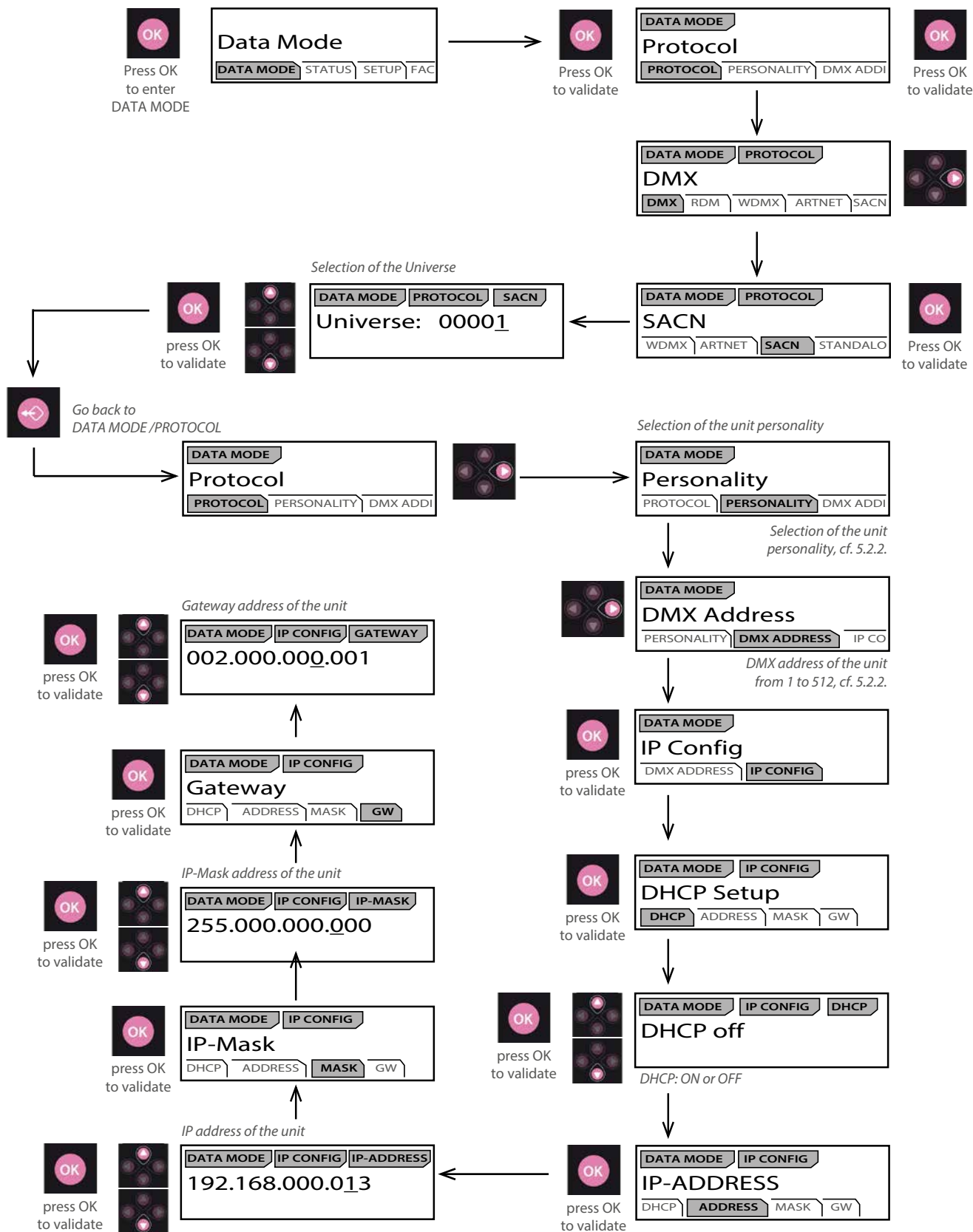

**Caution:**

Activate sACN in protocol mode beforehand.



## 5.6 Fan cooling modes

### 5.6.1 Range

Modes	Silent	Normal	Full
 <b>Cooling</b>	 < 38 dB(A)		
 <b>Brightness</b>	60 → 85%	80 → 95%	100%

### 5.6.2 Control

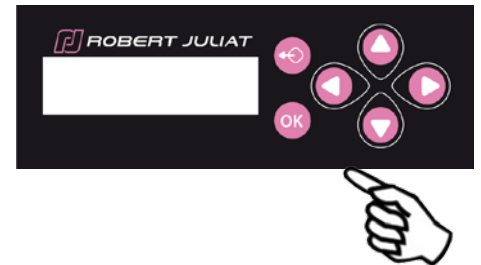
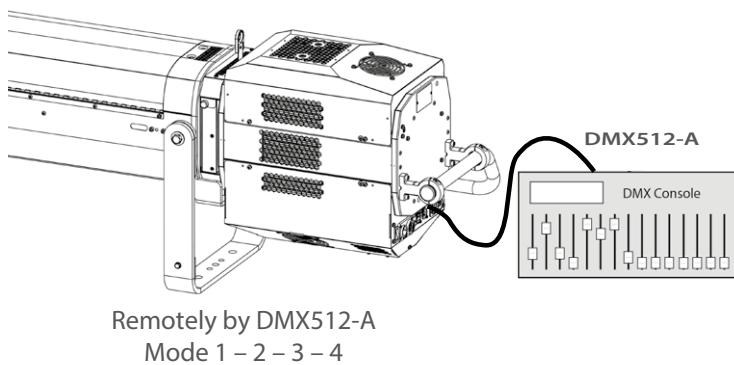

Locally → selection in  
SETUP/COOLING

## 6 Service

### 6.1 Preventive maintenance

#### 6.1.1 Frequency

General maintenance should be performed at least once a year or more frequently if the equipment is operated in adverse conditions (smoke, heat, humidity, touring, etc.).

#### 6.1.2 General cleaning

Remove dust from the unit.

Front glasses can be cleaned with solutions containing alcohol.

#### 6.1.3 General visual check

- No trace of heat.
- No loose contacts.
- No missing parts.
- Tighten mechanical assemblies (screws, bolts and nuts, etc.).

#### 6.1.4 LED source



- Do not touch the surface of the LED source (no contact with your hands or any tools).
- Do not put compressed air directly on the source.
- Contact a certified RJ distributor in case of residuals or other objects located on the surface of the LED source.

### 6.1.5 Optics

Only use solutions containing alcohol to clean optical parts (lenses).

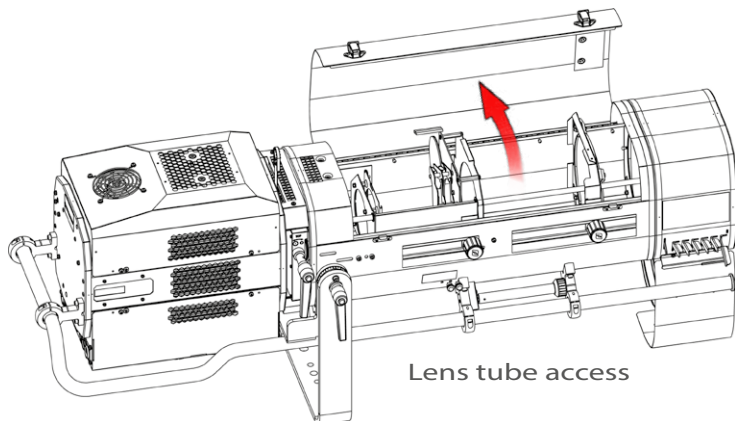

### 6.1.6 Inner fans & LED glass protection cleaning

Only use solutions containing alcohol to clean inner parts.

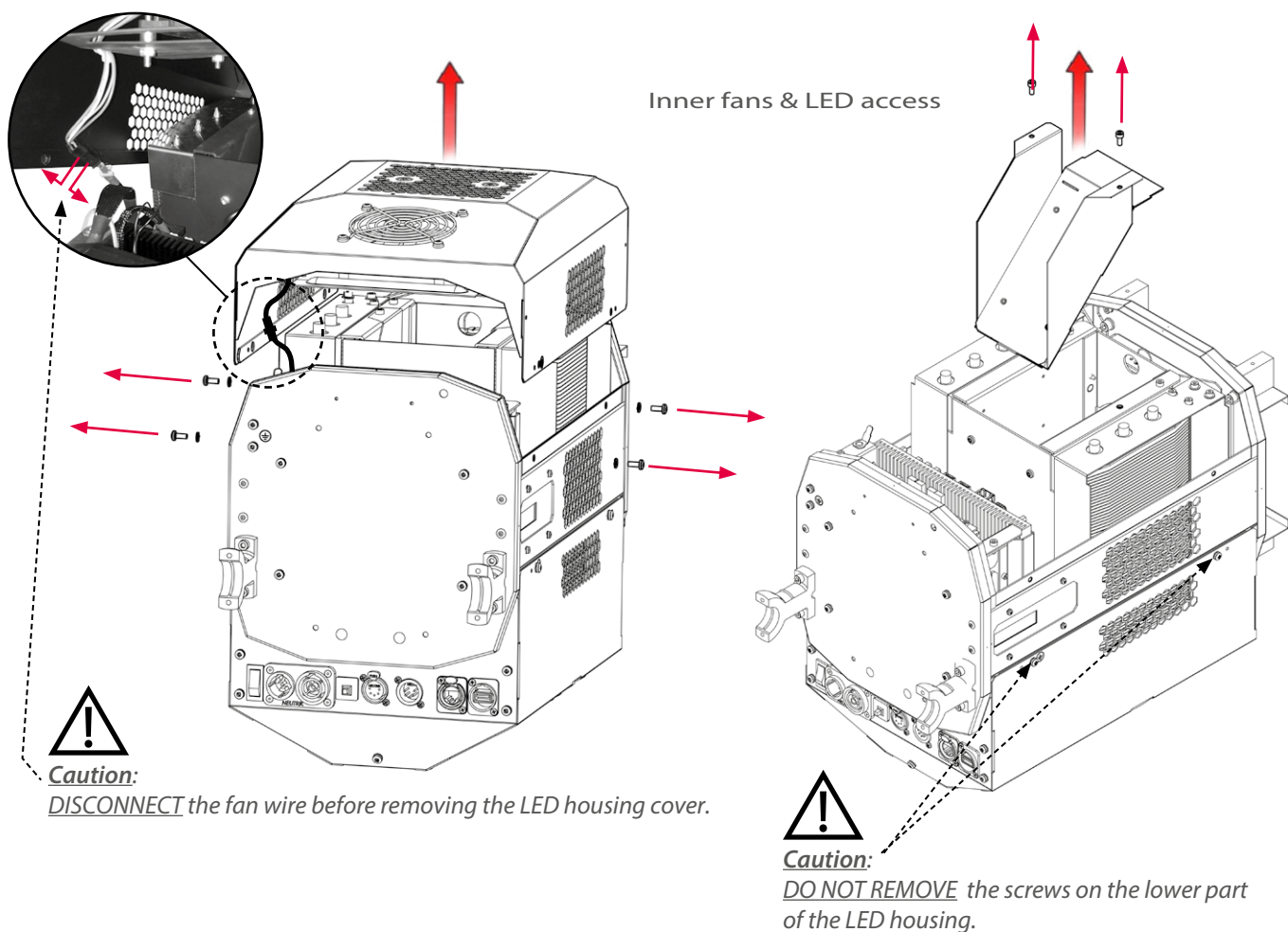

### 6.2 Analysis

In case of problem, contact RJ distributor with the following information:

- Model, version and serial number of the product.
- From the menu status:
  - Software version
  - LED board IDs
  - Device hours
- Description of the problem.



### 6.3 Local potentiometer

→ selection in SETUP/LOCAL POTENTIOMETER/CALIBRATION  
 Setting the minimum & maximum positions:

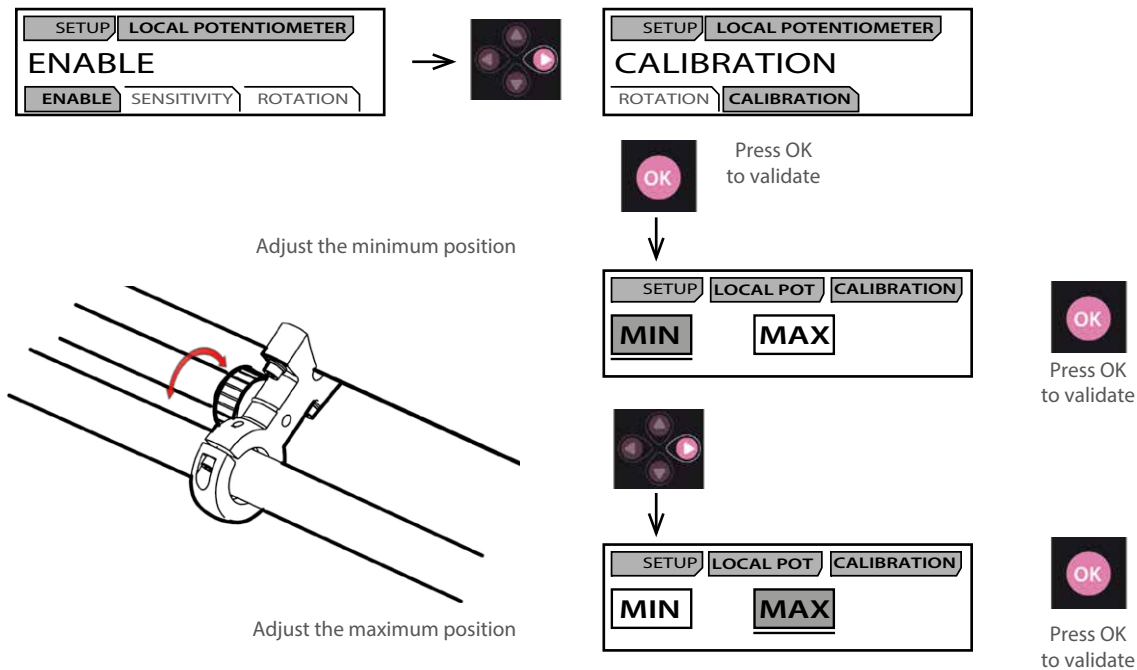

### 6.4 Electronic thermal management system

In case of overheating, light intensity will be reduced by the system.  
 "Power reduction X%" will be shown on the display with the reducing percentage.

### 6.5 Firmware update available soon.

### 6.6 Exploded view / Spare parts list available soon.