

ROBERT JULIAT



TIBO



SOURCES

LED

- 75W high intensity LED array
- Colour temperatures available:
 - WW: Warm White 3000K, CRI: 82 (ref. 533 WW)
 - NW: Neutral White 4000K, CRI: 82 (ref. 533 NW)
 - CW: Cool White 6500K, CRI: 82 (ref. 533 CW)
- Lumen maintenance of greater than 70% after 50.000 hours
- Separate flicker-free power supply (same characteristics as ZEP profile)
- Power consumption: 90W (sleep mode 5W)

TUNGSTEN

- Sockets:
 - GY9.5: 300/500/650W lamps (ref. 503)
 - G9.5: 600W (GKV type) lamps (ref. 513)
- Access to the lamp secured by 2 safety switches
- Convection cooling

OPTICS

- Two zoom ranges in one single unit (30 / 45° & 15 / 35°)
- Lamp houses:
 - LED: double condenser optics
 - Tungsten: ellipsoidal reflector
- Standard M-size gobo
- Simultaneous sharp focus on both gobo and shutters - sharp focus at every angle

FEATURES

- Die cast aluminium housing
- 4 shutters with user-friendly shutter-lock system
- 360° rotating fixture or yoke / gate / front accessories holder
- 135x135 mm colour runners

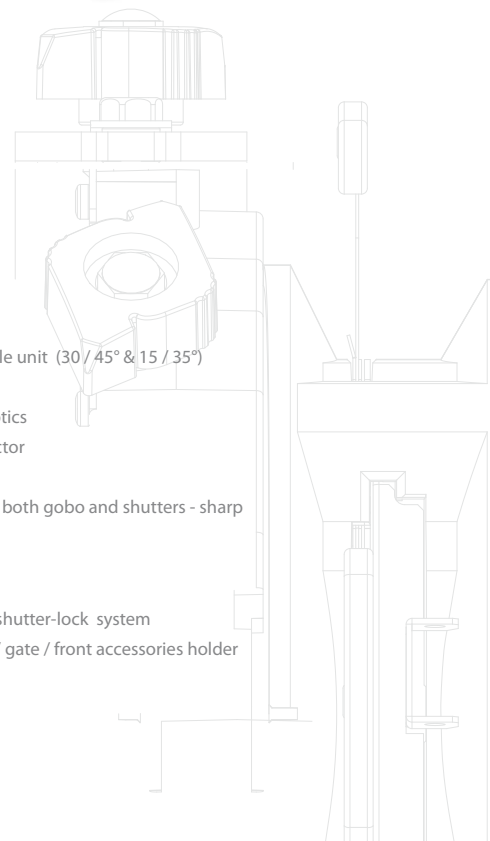



ZEP



SOURCE

- 150W high intensity LED array
- 2 colour temperatures available:
 - WW: Warm White 3200K
 - CW: Cool White 6000K
- Lumen maintenance of greater than 70% after 50.000 hours
- Power consumption: 185W (sleep mode 5W)

OPTICS

- SX optical system: double condenser optics
- Standard A-size gobo
- Simultaneous sharp focus on both gobo and shutters - sharp focus at every angle
- 3 zoom ranges available:
 - 643SX: 28 / 54°
 - 644SX: 16 / 35°
 - 641SX: 11 / 26°

PSU

- Built-in flicker-free power supply with noiseless variable forced air cooling
- Standard AC power distribution from 90 to 265V 50/60Hz
- Local or DMX control of light intensity (8 or 16 bits)
- No clipping or cut-out below 20% - high quality smoothing
- Strobe function
- Adjustable curves and response thru 4-button display with automatic light switch-off
- NeutriK® powerCON TRUE1 in and out connectors for daisy chaining

FEATURES

- Up to 8 shutters with user-friendly shutter-lock system
- Multi-function double gate for simultaneous use of gobo and iris
- 90° rotating lens tube / gate / front accessories holder
- Single and double colour runners
- Internal filter holder in lens tube: smaller gels – no light spill



ROBERT JULIAT

Does your project need **smaller**, compact lighting fixtures with the same Robert Juliat quality? Are you looking for a **brighter** LED lighting solution? Robert Juliat's latest **profiles** provide **perfect, cost-effective solutions** to match these criteria.

After successfully introducing the first framing spotlight with integrated LED light engine in 2010, Robert Juliat is now offering two innovative ranges of profile spots that combine **excellent dimming** with **homogenous projection quality**.

TIBO

A truly innovative, multiple light-source model, the TIBO profile presents a **compact** and **lightweight** solution in a visionary, **modern design**. TIBO offers a choice of different sources (**LED or tungsten**) specified for a comprehensive range of diverse applications. It also features an outstanding unique optical design that allows **two different zoom ranges in one single unit** and the option to integrate **wireless DMX technology** (LED version).

ZEP

ZEP is the same size and form factor as the popular Robert Juliat 600SX tungsten range. It incorporates a completely new light source offering **maximum output** – equivalent to some of the industry's standard tungsten spotlights – together with **very low power consumption**. This new **LED profile** incorporates an innovative and powerful 150W LED engine offering **two different colour temperatures**, a choice of **three zoom ranges** and the option to integrate **wireless DMX technology**.

Designed with Robert Juliat's trademark qualities of ergonomic perfection, optical and mechanical excellence, these two new profile ranges suit every application from the smallest theatre to the largest spectacular.

Lighting designers, technicians and business owners will all want to use TIBO and ZEP because of their exclusive operational features, reliability and fast maintenance, and the **cost savings** these all afford.

32, rue de Beaumont
60530 Fresnoy-en-Thelle | FRANCE
phone: +33 (0)3 44 26 51 89
fax: +33 (0)3 44 26 90 79
e-mail: info@robertjuliat.fr
www.robertjuliat.com

UNCOMPROMISING QUALITY SINCE 1919

48, Capital Drive
Wallingford, CT 06492 | USA
phone: +1 (203) 294 0481
fax: +1 (203) 294 0482
e-mail: info@robertjuliatamerica.com
www.robertjuliat.com